



# Instruction Manual Book

Item code: BH64

# F4U CORSAIR

Glow and EP

**New improvement**

**ALL Balsa - Ply Wood Construction.  
Covered in a Heat - Shrink Film with Printed.  
Including Rotary 90 Degree Electric Retract  
& Electric Retract Tail Gear with CNC Suspension Metal Struts.**

95% PRE BUILT  
**ARF**  
ALMOST READY TO FLY



## 95% ALMOST READY TO FLY

### SPECIFICATION:

- Wingspan: 2,280 mm (89.76 in).
- Length: 1,800 mm (70.87 in).
- Weight: 9.6 - 10kg (21.1 - 22lbs).
- Wing area: 94.6dm<sup>2</sup>.
- Wing loading: 101.5g/dm<sup>2</sup>.
- Servo mount: 42mm x 21mm.
- Spinner size: Corsair style (not included).
- Wing type: Naca Airfoils.
- Main gear type: Rotary 90 degree electric retract gear and CNC suspension metal struts (included).
- Tail gear type: Electric retract gear with CNC suspension metal struts (included).

### Parts listing required (not included):

- Radio: 7 channels.
- Servo: 09 size (39.9 x 20.1 x 38.1)mm. Standard high torque servos.
- Engine : 55 - 65 cc gas.
- Motor: Brushless outrunner 5000 - 6500W, 230KV.
- Propeller: Suit with your engine.

### Recommended receiver battery (not included):

- Motor: RIMFIRE. 50 cc.
- Lipo cell: 12 cells 5500 - 6000mAh.
- Receiver battery: 6.0V- 7.4V 2600-3200mAh (3 Packs).
- ESC: 120A.

## TABLE OF CONTENTS

▶ Warranty.....	3	▶ Installing the throttle.....	21
▶ Disclaimer.....	3	▶ Mounting the cowl.....	22
▶ Safety precaution.....	3	▶ Installing horizontal stabilizer.....	23
▶ Important building notes.....	3	▶ Installing the tail gear, rudder.....	25
▶ Suggestion.....	3	▶ Installing valve control.....	28
▶ Flight warnings.....	3	▶ Cleaning the valve.....	29
▶ Covering tools.....	3	▶ Installing the switch, receiver and battery.....	31
▶ Adhesives and required tools.....	4	▶ Installing the switch.....	31
▶ Academy of Model Aeronautics National Model Aircraft Safety Code.....	4	▶ Installing cockpit fuselage.....	31
▶ Part listing ( not included ).....	6	▶ Installing the wing to the fuselage.....	33
▶ Tools & supplies needed.....	6	▶ Installing the propeller.....	34
▶ Symbols used throughout this instruction manual, comprise.....	6	▶ Balancing.....	36
▶ Preparations.....	8	▶ Lateral balance.....	36
▶ Installing the ailerons and flaps.....	8	▶ Control throws.....	36
▶ Installing the ailerons and flap servos.....	9	▶ Pre-flight check.....	36
▶ Installing the control horns and linkages.....	10	▶ Main gear dimensional detail.....	38
▶ Installing the electric landing gear.....	12	▶ Tail gear dimensional detail.....	38
▶ Installing the engine mount.....	17	▶ Exploded view.....	39
▶ Installing the electric motor ( ep version).....	17		
▶ Installing the engine and fuel tank.....	18		
▶ Installing the engine.....	19		
▶ Installing the fuselage servos.....	20		

## INTRODUCTION

Thank you for purchasing Black Horse Model products. With over 19 years experience in production and fly testing, Black Horse Model is committed to bring the best quality products and good service to customers. Along with a team of creative engineers and skilled workers, we will always accompany with customers by our great experiences, fully enthusiasm... which will burn our passion!! Joining with us to explore and conquer challenges in the sky ...

Your satisfaction is our success. Please read through this manual before starting construction.

**Academy of Model Aeronautics:** If you are not already a member of the AMA, please join! The AMA is the governing body of model aviation and membership provides liability insurance coverage, protects modelers' rights and interests and is required to fly at most R/C sites.

### Academy of ModelAeronautics

5151 East Memorial Drive Muncie IN 47302-9252

Tele. (800) 435-9262

Fax. (765) 741-0057

Or via the Internet at: <http://www.modelaircraft.org>



## WARRANTY

Black Horse Model guarantees the component parts in this kit to be free from defects in both material and workmanship at the date of purchase by the purchaser.

This warranty does not cover cosmetic damage or damage due to acts of God, accident, misuse, abuse, negligence, commercial use, or modification of or to any part of the Product.

This warranty does not cover damage due to improper installation, operation, maintenance, or attempted repair by anyone other than Black Horse Model.

Further, Black Horse Model reserves the right to change or modify this warranty without notice.

## DISCLAIMER

Read this disclaimer carefully before using this product. Please strictly follow the instruction manual to assemble and use this.

In that Black Horse Model has no control over the final assembly or material used for final assembly, Black Horse Model is not responsible for loss of use, or other incidental or consequential damages.

Furthermore, Black Horse Model cannot be held liable for personal injury or property damage caused by the use or misuse of Black Horse Model products. By the act of using the user-assembled products, the user accepts all resulting liability.

## SAFETY PRECAUTION

- This is not a toy and pilots must be over the age of 14
- Be sure that no other flyers are using your radio frequency.
- Do not smoke near fuel
- Store fuel in a cool, dry place, away from children and pets.
- Wear safety glasses.
- The glow plug clip must be securely attached to the glow plug.
- Do not flip the propeller with your fingers.
- Keep loose clothing and wires away from the propeller.
- Do not start the engine if people are near. Do not stand in line with the side of the propeller.
- Make engine adjustments from behind the propeller only. Do not reach around the spinning propeller.
- Moisture causes damage to electronics. Avoid water exposure to all equipment not specifically designed and protected for this purpose.

## IMPORTANT BUILDING NOTES

- Please trial fit all the parts. Make sure you have the correct parts and that they fit and are aligned properly before gluing! This will assure proper assembly. This kit is hand made from natural materials, every plane is unique and minor adjustments may have to be made. However, you should find the fit superior and assembly simple.
- The painted and plastic parts used in this kit are fuel proof. However, they are not tolerant of many harsh chemicals including the following: paint thinner, C/A glue accelerator, C/A glue debonder and acetone. Do not let these chemicals come in contact with the colors on the covering and the plastic parts.
- Some parts included in this kit such as the cowl or wheel pants are made of fiberglass, the fibers of which may cause eye, skin and respiratory tract irritation. Never blow into a part to remove fiberglass dust, as the dust will blow back into your eyes. Always wear safety goggles, a particle mask and rubber gloves when grinding, drilling and sanding fiberglass parts. Vacuum the parts and the work area thoroughly after working with fiberglass parts.

## SUGGESTION

To avoid scratching your new airplane, do not unwrap the pieces until they are needed for assembly. Cover your workbench with an old towel or brown paper, both to protect the aircraft and to protect the table. Keep a couple of jars or bowls handy to hold the small parts after you open the bag.

## FLIGHT WARNINGS

- Always operate in open areas, away from factories, hospitals, schools, buildings and houses etc.
- NEVER fly your aircraft close to people or built up areas.
- NEVER fly near power lines, aerials or other dangerous areas including airports, motorways etc.
- NEVER fly in wet conditions or on windy or stormy days.
- ALWAYS adjust the engine from behind the propeller, and do not allow any part of your body to be in line with the propeller.
- THE PROPELLER IS DANGEROUS Keep fingers, clothing (ties, shirt sleeves, scarves) or any other loose objects that could be caught or drawn in, away from the propeller. Take care at ALL times.
- NEVER use damaged or deformed propellers or spinners.
- Keep all onlookers (especially small children and animals) well back from the area of operation. This is a flying aircraft, which will cause serious injury in case of impact with a person or animal.
- DO NOT dispose of empty fuel containers on a fire, this can lead to an explosion.

## FLIGHT WARNINGS

- When ready to fly, first extend the transmitter aerial.
- Switch on the transmitter.
- Switch on the receiver.
- Check that the wings are correctly fitted to the fuselage.
- Operate the control sticks on the transmitter and check that the control surfaces move freely and in the CORRECT directions.
- Check that the transmitter batteries have adequate power.
- ALWAYS take off into the wind.
- If the model does not respond correctly to the controls, land it as soon as possible and correct the fault.
- ALWAYS land the model INTO the wind, this ensures that the model lands at the slowest possible speed.
- Switch off the receiver.
- Switch off the transmitter.
- Empty the fuel tank after flying, fuel left in the tank can cause corrosion and lead to engine problems.

## COVERING TOOLS

- Top Flite® MonoKote® Sealing Iron
- Top Flite Hot Sock Iron Cover
- Top Flite MonoKote Trim Seal Iron
- Top Flite MonoKote Heat Gun

## ADHESIVES AND REQUIRED TOOLS

- Thin CA
- 30-minute epoxy
- 6-minute epoxy
- Threadlocker thread locking cement
- Mixing sticks
- Mixing cups (GPMR8056)
- Epoxy brushes
- Denatured alcohol
- Canopy Glue
- Felt-tipped pen or pencil
- Flat screwdriver
- Adjustable wrench
- Drill
- Hobby knife
- Masking tape
- Phillips screwdriver (large)
- Phillips screwdriver (small)
- Ruler
- Sandpaper
- Soldering iron
- Solder
- Hex wrench
- Drill bit: 1/16-inch (1.5mm), 5/64-inch (2mm), 1/8-inch (3,2mm), 3/16-inch (4,8mm), 11/64-inch (4.5mm), 13/64-inch (5,2mm), 1/4-inch (6,4mm)

## Academy of Model Aeronautics National Model Aircraft Safety Code

**Effective January 1, 2014**

A. GENERAL: A model aircraft is a non-human-carrying aircraft capable of sustained flight in the atmosphere. It may not exceed limitations of this code and is intended exclusively for sport, recreation, education and/or competition. All model flights must be conducted in accordance with this safety code and any additional rules specific to the flying site.

1. Model aircraft will not be flown:
  - (a) In a careless or reckless manner.
  - (b) At a location where model aircraft activities are prohibited.
2. Model aircraft pilots will:
  - (a) Yield the right of way to all human-carrying aircraft.
  - (b) See and avoid all aircraft and a spotter must be used when appropriate. (AMA Document #540-D.)
  - (c) Not fly higher than approximately 400 feet above ground level within three (3) miles of an airport without notifying the airport operator.
  - (d) Not interfere with operations and traffic patterns at any airport, heliport or seaplane base except where there is a mixed use agreement.
  - (e) Not exceed a takeoff weight, including fuel, of 55 pounds unless in compliance with the AMA Large Model Airplane program. (AMA Document 520-A.)
  - (f) Ensure the aircraft is identified with the name and address or AMA number of the owner on the inside or affixed to the outside of the model aircraft. (This does not apply to model aircraft flown indoors.)
  - (g) Not operate aircraft with metal-blade propellers or with gaseous boosts except for helicopters operated under the provisions of AMA Document #555.
  - (h) Not operate model aircraft while under the influence of alcohol or while using any drug that could adversely affect the pilot's ability to safely control the model.
  - (i) Not operate model aircraft carrying pyrotechnic devices that explode or burn, or any device which propels a projectile or drops any object that creates a hazard to persons or property.

Exceptions:

- Free Flight fuses or devices that burn producing smoke and are securely attached to the model aircraft during flight.
- Rocket motors (using solid propellant) up to a G-series size may be used provided they remain attached to the model during flight. Model rockets may be flown in accordance with the National Model Rocketry Safety Code but may not be launched from model aircraft.

- Officially designated AMA Air Show Teams (AST) are authorized to use devices and practices as defined within the Team AMA Program Document. (AMA Document #718.)
- (j) Not operate a turbine-powered aircraft, unless in compliance with the AMA turbine regulations. (AMA Document #510-A.)
- 3. Model aircraft will not be flown in AMA sanctioned events, air shows or model demonstrations unless:
  - (a) The aircraft, control system and pilot skills have successfully demonstrated all maneuvers intended or anticipated prior to the specific event.
  - (b) An inexperienced pilot is assisted by an experienced pilot.
- 4. When and where required by rule, helmets must be properly worn and fastened. They must be OSHA, DOT, ANSI, SNELL or NOCSAE approved or comply with comparable standards.
- B. RADIO CONTROL (RC)
  - 1. All pilots shall avoid flying directly over unprotected people, vessels, vehicles or structures and shall avoid endangerment of life and property of others.
  - 2. A successful radio equipment ground-range check in accordance with manufacturer's recommendations will be completed before the first flight of a new or repaired model aircraft.
  - 3. At all flying sites a safety line(s) must be established in front of which all flying takes place. (AMA Document #706.)
    - (a) Only personnel associated with flying the model aircraft are allowed at or in front of the safety line.
    - (b) At air shows or demonstrations, a straight safety line must be established.
    - (c) An area away from the safety line must be maintained for spectators.
    - (d) Intentional flying behind the safety line is prohibited.
  - 4. RC model aircraft must use the radio-control frequencies currently allowed by the Federal Communications Commission (FCC). Only individuals properly licensed by the FCC are authorized to operate equipment on Amateur Band frequencies.
  - 5. RC model aircraft will not knowingly operate within three (3) miles of any pre-existing flying site without a frequency-management agreement. (AMA Documents #922 and #923.)
  - 6. With the exception of events flown under official AMA Competition Regulations, excluding takeoff and landing, no powered model may be flown outdoors closer than 25 feet to any individual, except for the pilot and the pilot's helper(s) located at the flightline.
  - 7. Under no circumstances may a pilot or other person touch an outdoor model aircraft in flight while it is still under power, except to divert it from striking an individual.
  - 8. RC night flying requires a lighting system providing the pilot with a clear view of the model's attitude and orientation at all times. Hand-held illumination systems are inadequate for night flying operations.
  - 9. The pilot of an RC model aircraft shall:
    - (a) Maintain control during the entire flight, maintaining visual contact without enhancement other than by corrective lenses prescribed for the pilot.
    - (b) Fly using the assistance of a camera or First-Person View (FPV) only in accordance with the procedures outlined in AMA Document #550.
    - (c) Fly using the assistance of autopilot or stabilization system only in accordance with the procedures outlined in AMA Document #560.
- C. FREE FLIGHT
  - 1. Must be at least 100 feet downwind of spectators and automobile parking when the model aircraft is launched.
  - 2. Launch area must be clear of all individuals except mechanics, officials, and other fliers.
  - 3. An effective device will be used to extinguish any fuse on the model aircraft after the fuse has completed its function.
- D. CONTROL LINE
  - 1. The complete control system (including the safety thong where applicable) must have an inspection and pull test prior to flying.
  - 2. The pull test will be in accordance with the current Competition Regulations for the applicable model aircraft category.
  - 3. Model aircraft not fitting a specific category shall use those pull-test requirements as indicated for Control Line Precision Aerobatics.
  - 4. The flying area must be clear of all utility wires or poles and a model aircraft will not be flown closer than 50 feet to any above-ground electric utility lines.
  - 5. The flying area must be clear of all nonessential participants and spectators before the engine is started.

**PARTS LISTING (NOT INCLUDED).**

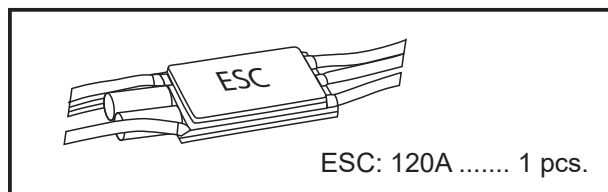
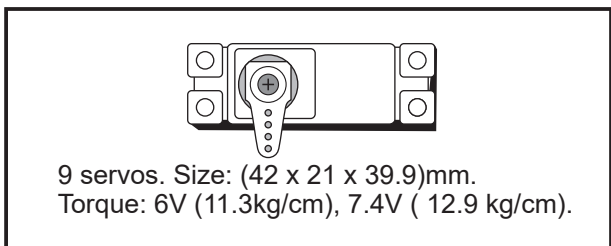
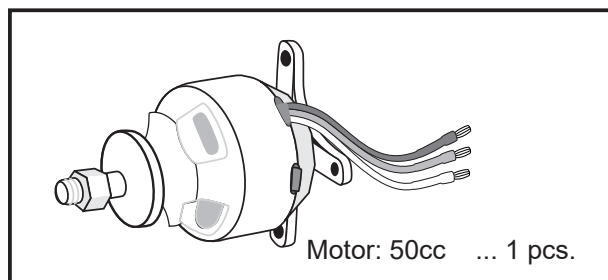
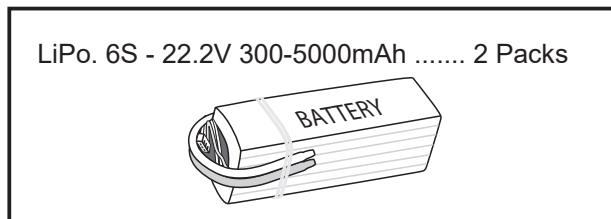
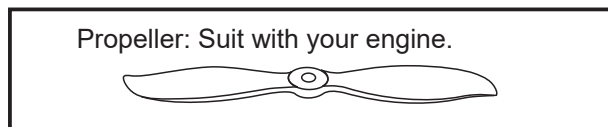
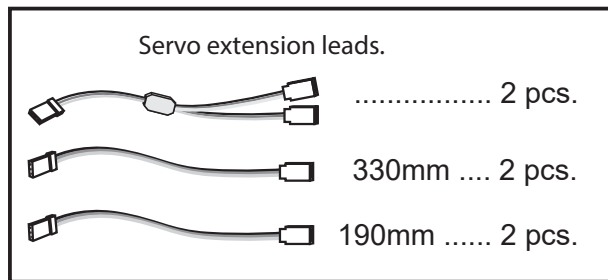
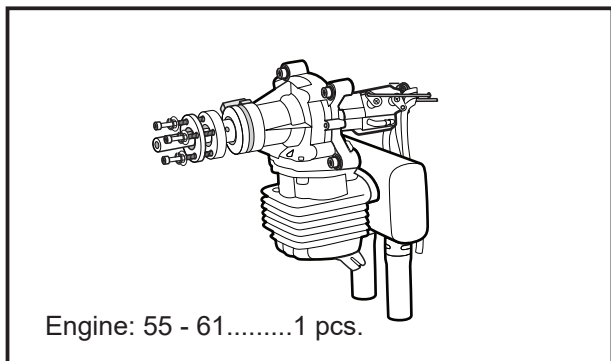

**TOOLS & SUPPLIES NEEDED.**

CA Medium C/A glue	Straight edge ruler.	EPOXY A EPOXY B 30 minute epoxy. 5 minute epoxy.	Hex Wrench.	Hand or electric drill.
Threadlocker (screw cement).	2 bender plier	Screw driver	Some more tools. <ul style="list-style-type: none"> <li>▪ Assorted drill bits.</li> <li>▪ Masking tape.</li> <li>▪ Paper towels.</li> <li>▪ Rubbing alcohol</li> <li>▪ 90° square or builder's triangle.</li> </ul>	
Modeling knife.	Wire cutters.	Pliers		



**Symbols used throughout this instruction manual, comprise:**

Cut off excess.	Apply threadlocker (screw cement).	Must be purchased separately!
Cut off shaded portion carefully.	Apply instant glue (C.A glue, super glue).	Ensure smooth, non-binding movement when assembling.
Pay close attention here.	Apply epoxy glue.	Drill holes using the stated. (in this case 1.5mm Ø).
Take particular care here.	Assemble left and right sides the same way.	The number of times the same way Assembly (in this case twice).
<b>Warning!</b>	▶ Set all screws securely. If they come off during flight you will lose control of your aircraft!	

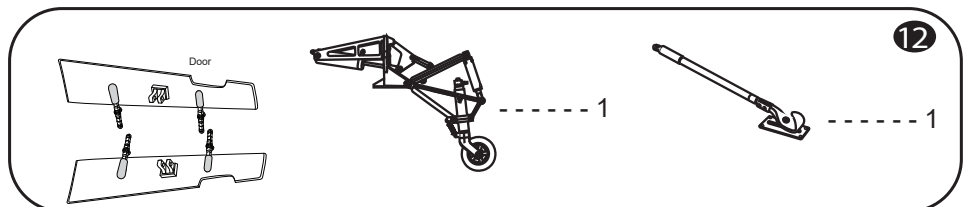
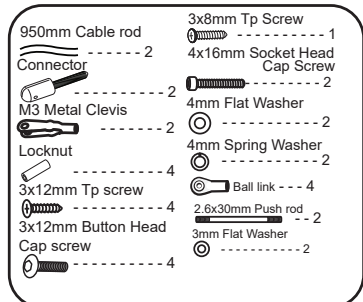
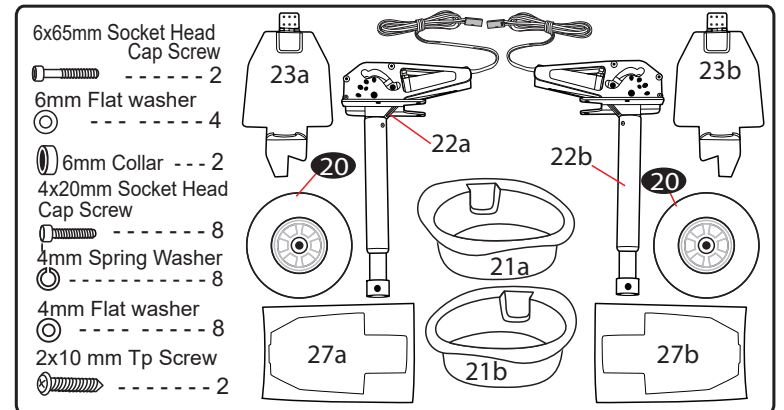
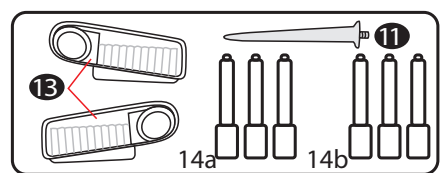
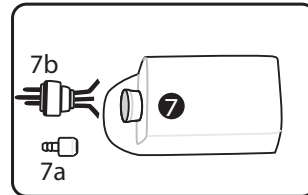
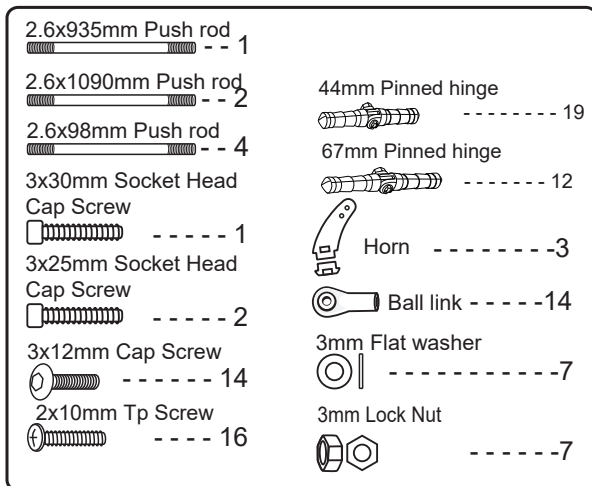
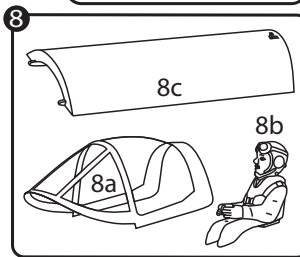
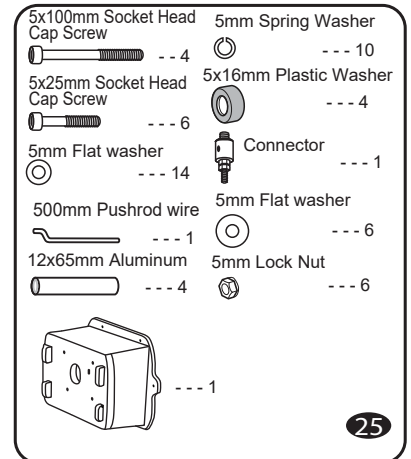
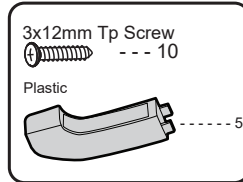
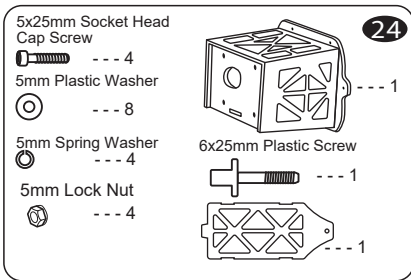
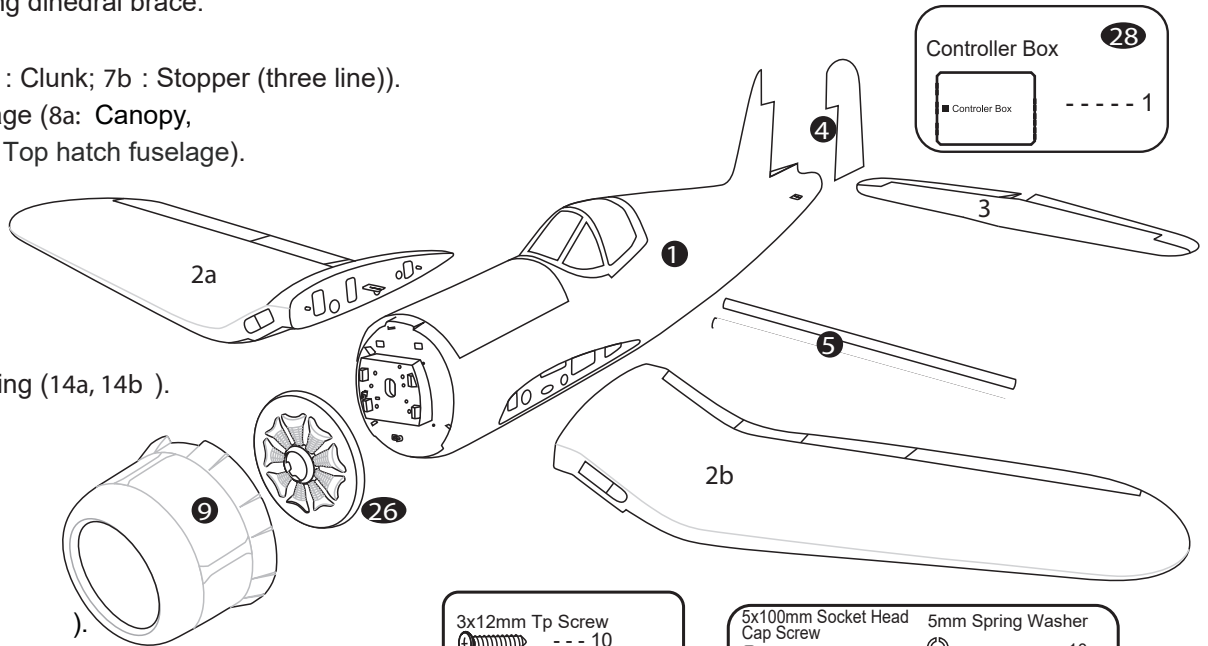
- 1 : Fuselage.
- 2 : Wing panel (2a, 2b ).
- 3 : Horizontal stabilizer
- 4 : Rudder.
- 5 : Aluminium wing dihedral brace.
- 6 : ...
- 7 : Fuel Tank (7a : Clunk; 7b : Stopper (three line)).
- 8 : Cockpit fuselage (8a: Canopy, 8b: Pilot, 8c: Top hatch fuselage).
- 9 : Cowling.
- 10 : n/a
- 11 : Antenna.
- 12 : Tail gear set.
- 13 : Wing radiator.
- 14 : Gun set for wing (14a, 14b ).
- 15 : n/a
- 16 : n/a
- 17 : n/a
- 18 : n/a
- 19 : n/a
- 20 : Wheels.
- 21 : Wheel well (21a, 21b)
- 22 : Retract main gear (22a, 22b ).
- 23 : Door strut gear (23a, 23b ).
- 24 : Wood - motor mount.
- 25 : Engine mount.
- 26 : n/a
- 27 : Mounting gear (27a, 27b)
- 28 : Controller Box



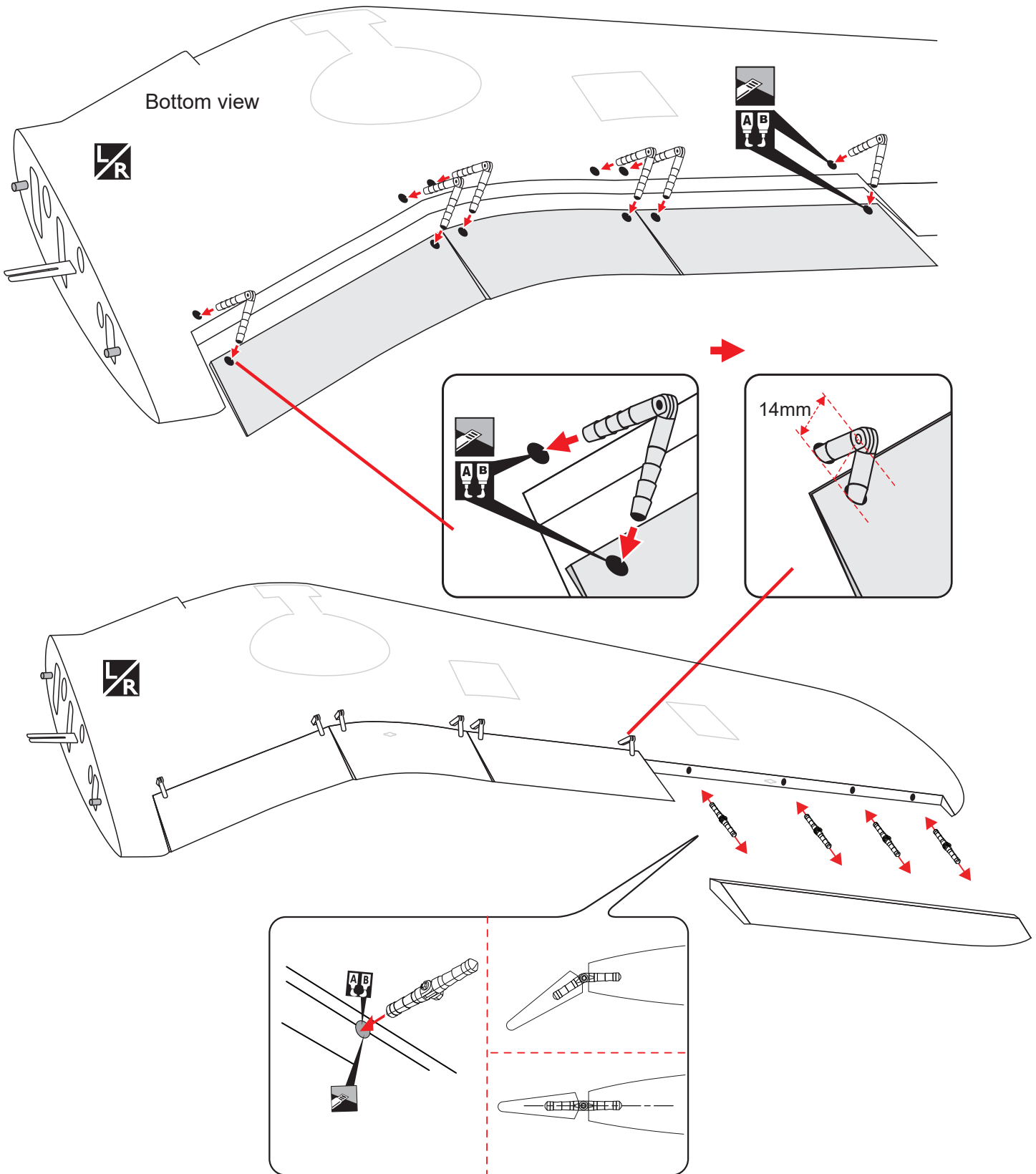

### INSTALLING THE AILERONS AND FLAPS.

- 44mm Pinned hinge  ..... 8
- 67mm Pinned hinge  ..... 12



 Cut off shaded portion carefully.

 Apply epoxy glue.

 Assemble left and right sides the same way.



**INSTALLING THE AILERONS AND FLAPS SERVOS.**

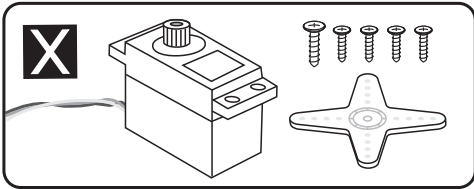

1. Install the rubber grommets and brass eyelets onto the aileron servos.
2. Using a modeling knife, remove the covering from over the pre-cut servo arm exit hole on the aileron servo tray / hatch. This hole will allow the servo arm to pass through when installing the aileron pushrods.

3. Place the servo into the servo tray. Center the servo within the tray and drill 1.5mm pilot holes through the block of wood for each of the four mounting screws provided with the servo.

4. Using the thread as a guide and using masking tape, tape the servo lead to the end of the thread: carefully pull the thread out. When you have pulled the servo lead out, remove the masking tape and the servo lead from the thread.

5. Place the servo into the servo tray/ hatch into the servo box on the bottom of the wing and drill 1.5mm pilot holes through the tray and servo box for each of the four mounting screws. Secure the servo tray in place using the mounting screws provided.

6. Repeat step # 2 - # 5 to install the second aileron servo in the opposite wing half.

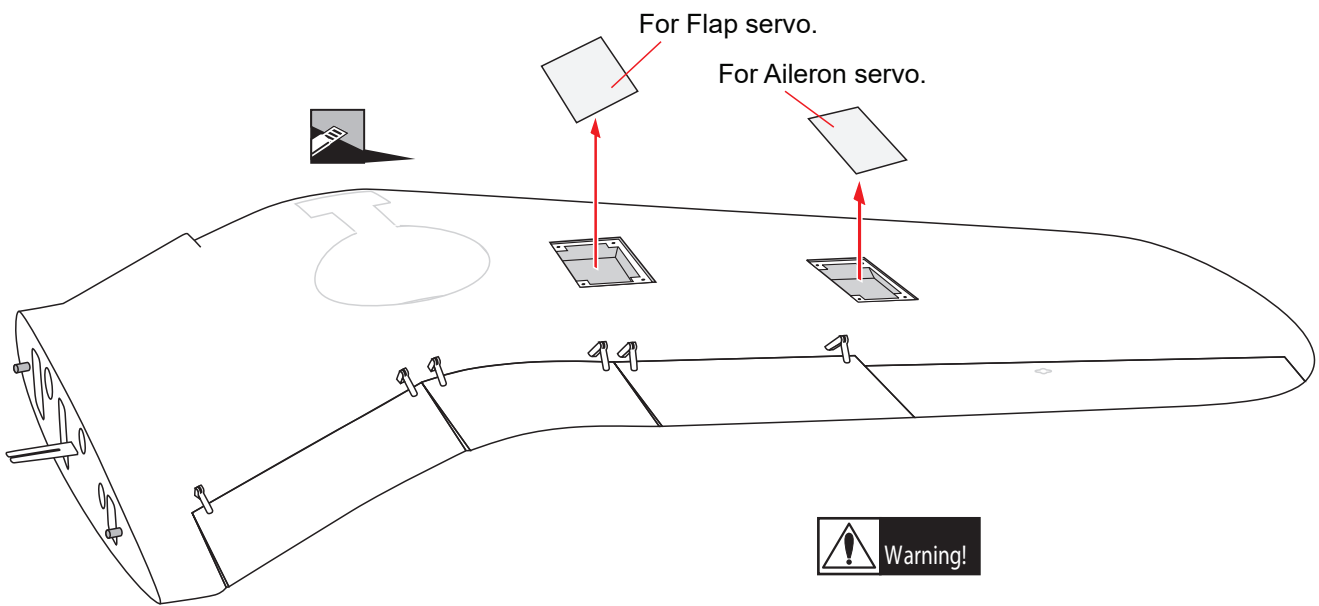

2x10mm Tp Screw ----- 16	3mm Flat Screw ----- 4	Horn ----- 2	Ball link ----- 8	3x15mm Tp Screw ----- 6
3mm Lock Nut ----- 4	3x12mm Button Head Cap Screw ----- 8	Horn ----- 2	2.6x98mm Push rod ----- 4	Plastic ----- 2

Cut off shaded portion carefully.

Assemble left and right sides the same way.

The number of times the same way Assembly (in this case twice).

Pay close attention here.

Must be purchased separately!

Drill holes using the stated. (in this case 1.5mm Ø).

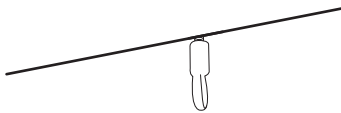
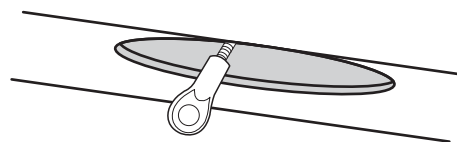
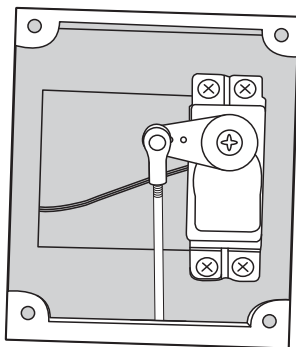
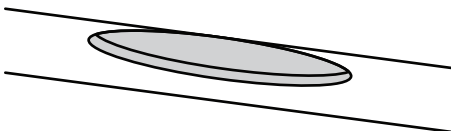
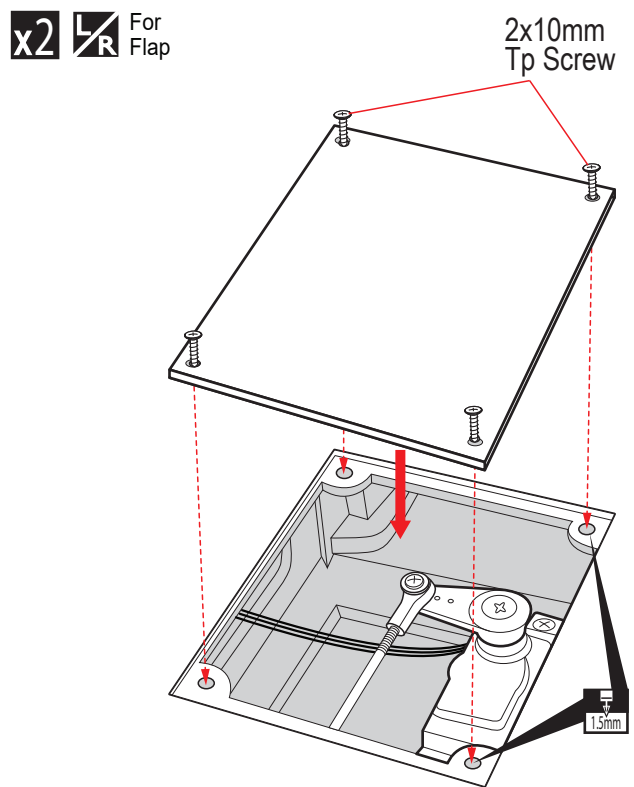
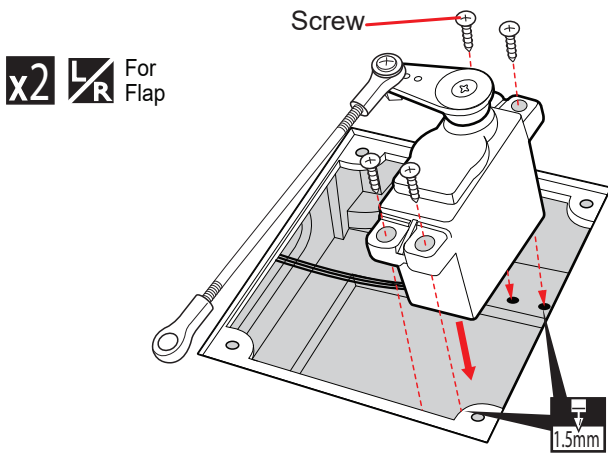
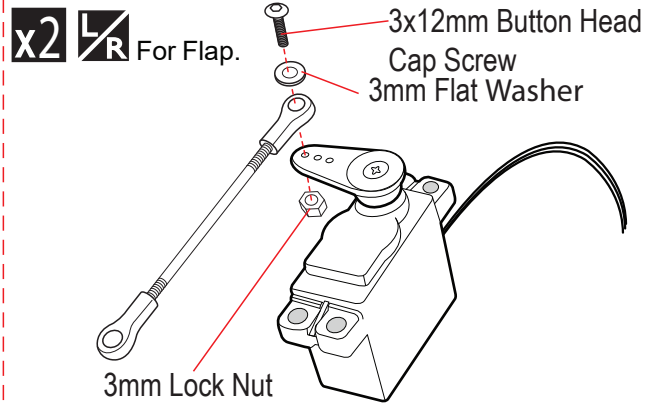
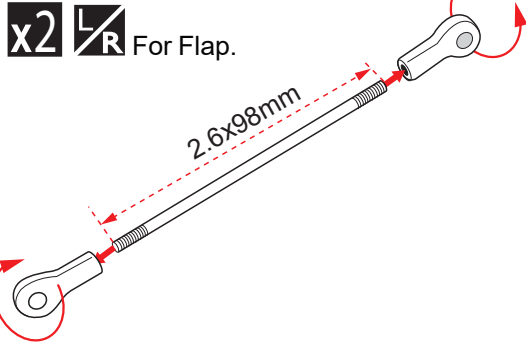
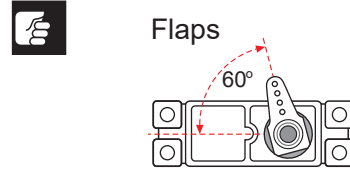
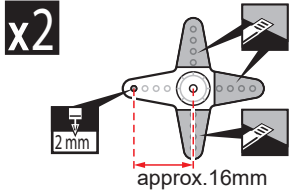

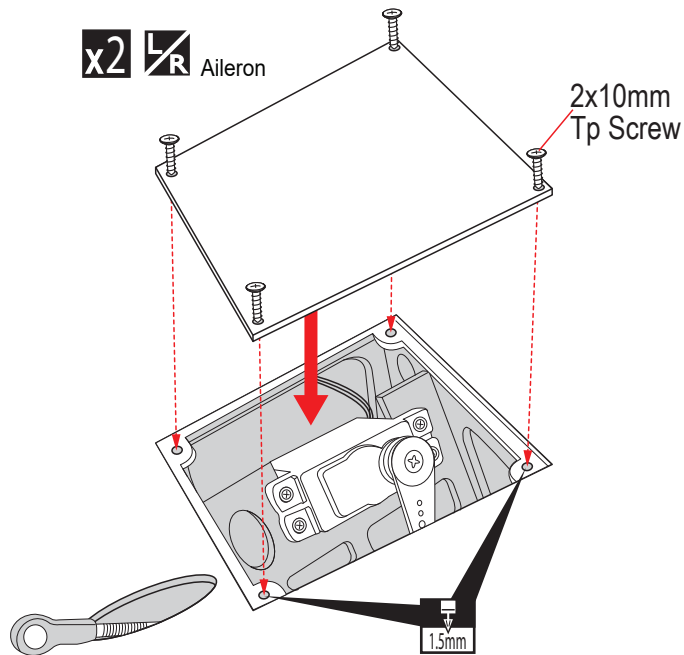
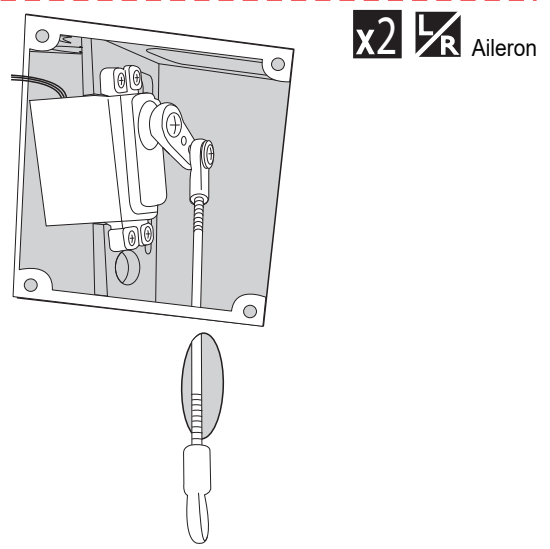
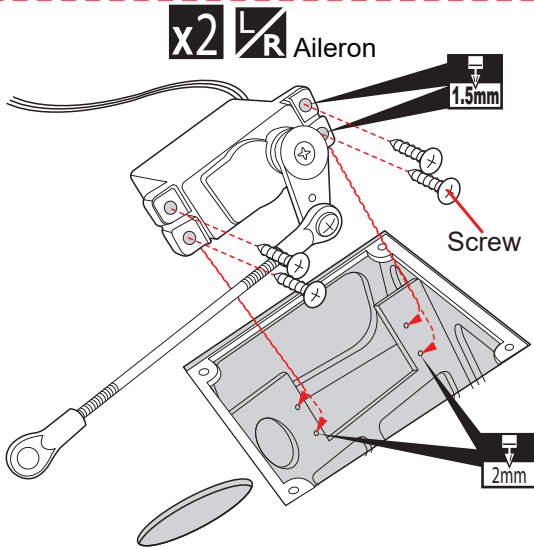
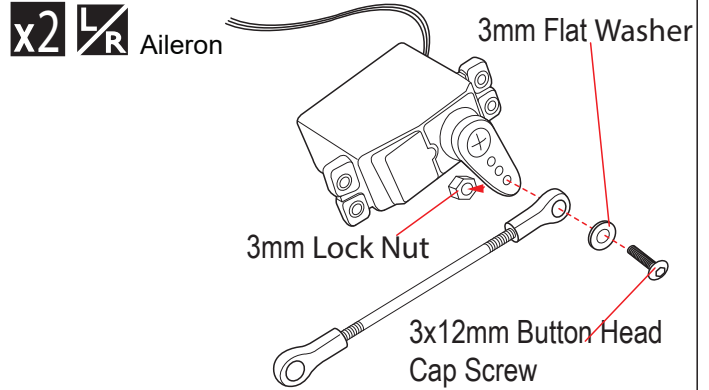
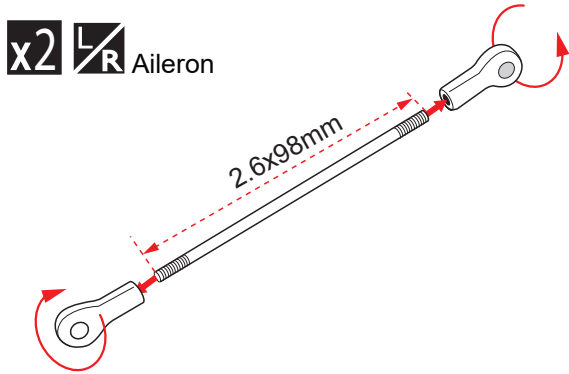
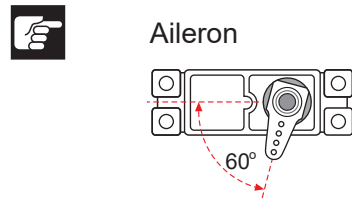
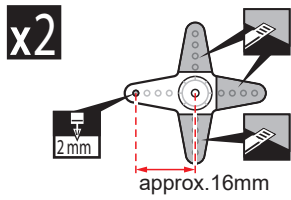

Cut off shaded portion carefully.

Drill holes using the stated. (in this case 1.5mm Ø).

Pay close attention here.

**x2** The number of times the same way Assembly (in this case twice).

**L/R** Assemble left and right sides the same way.

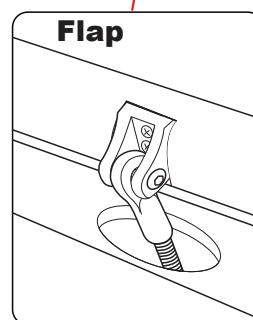
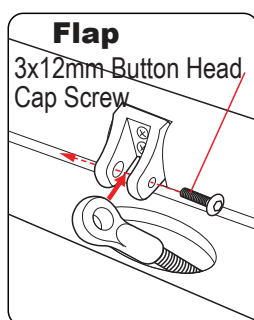
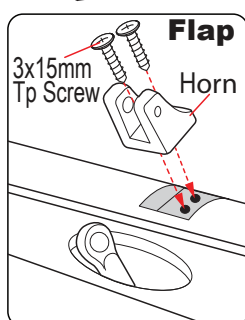
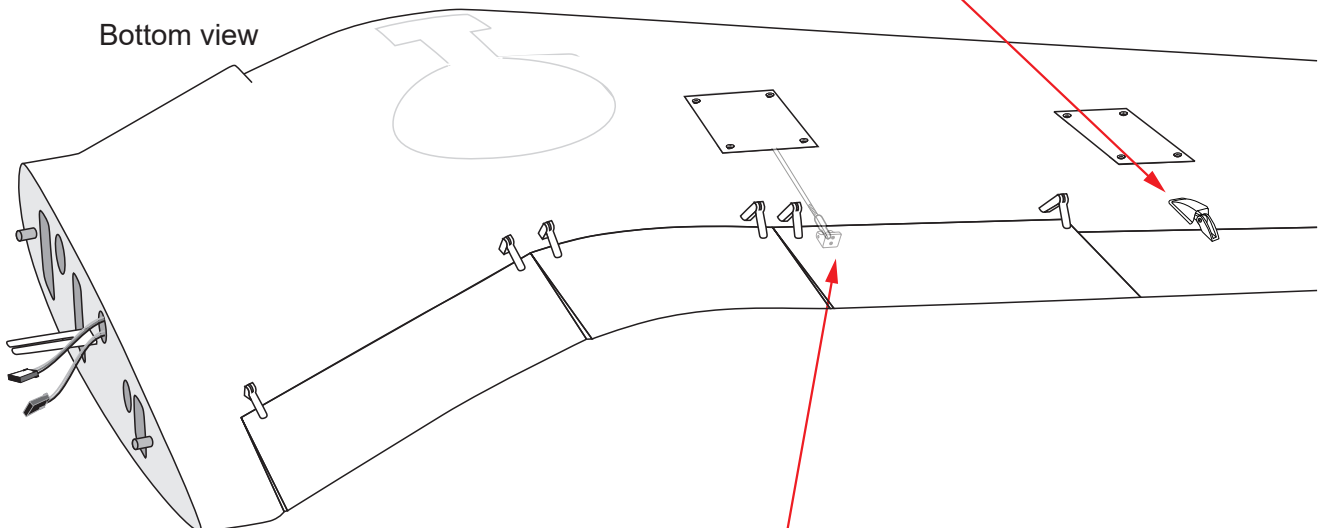
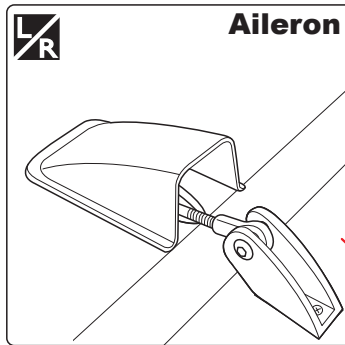
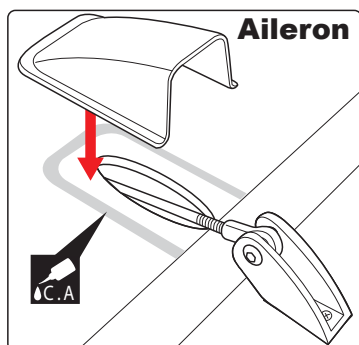
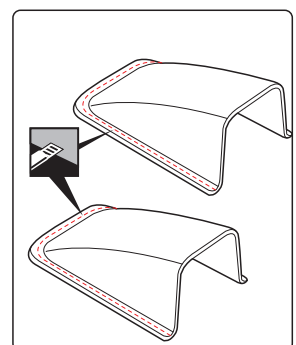
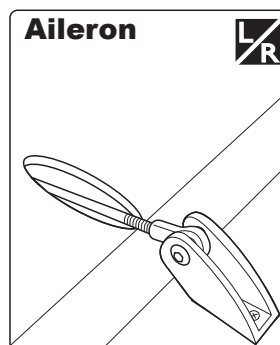
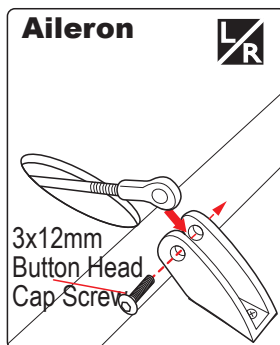
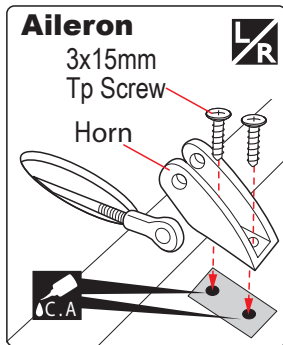
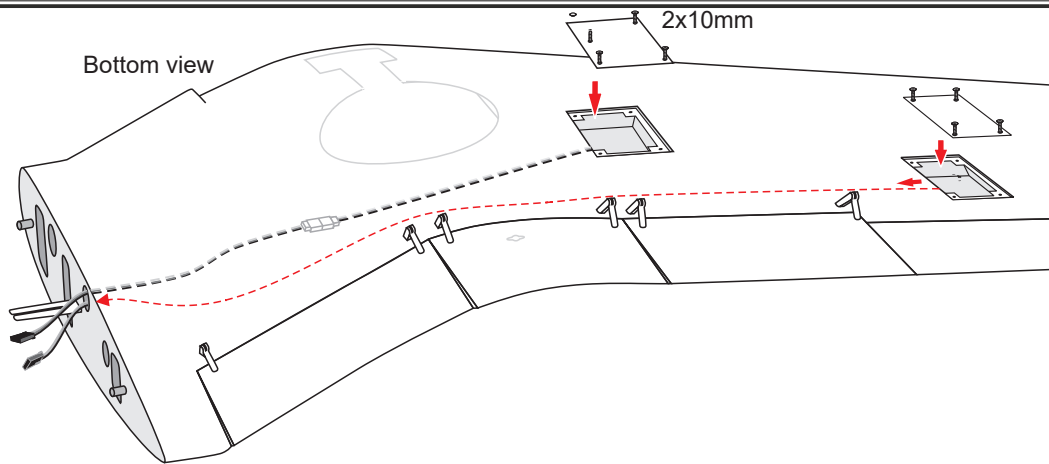

- Cut off shaded portion carefully.
- Apply epoxy glue.
- Apply instant glue (C.A glue, super glue).
- Assemble left and right sides the same way.

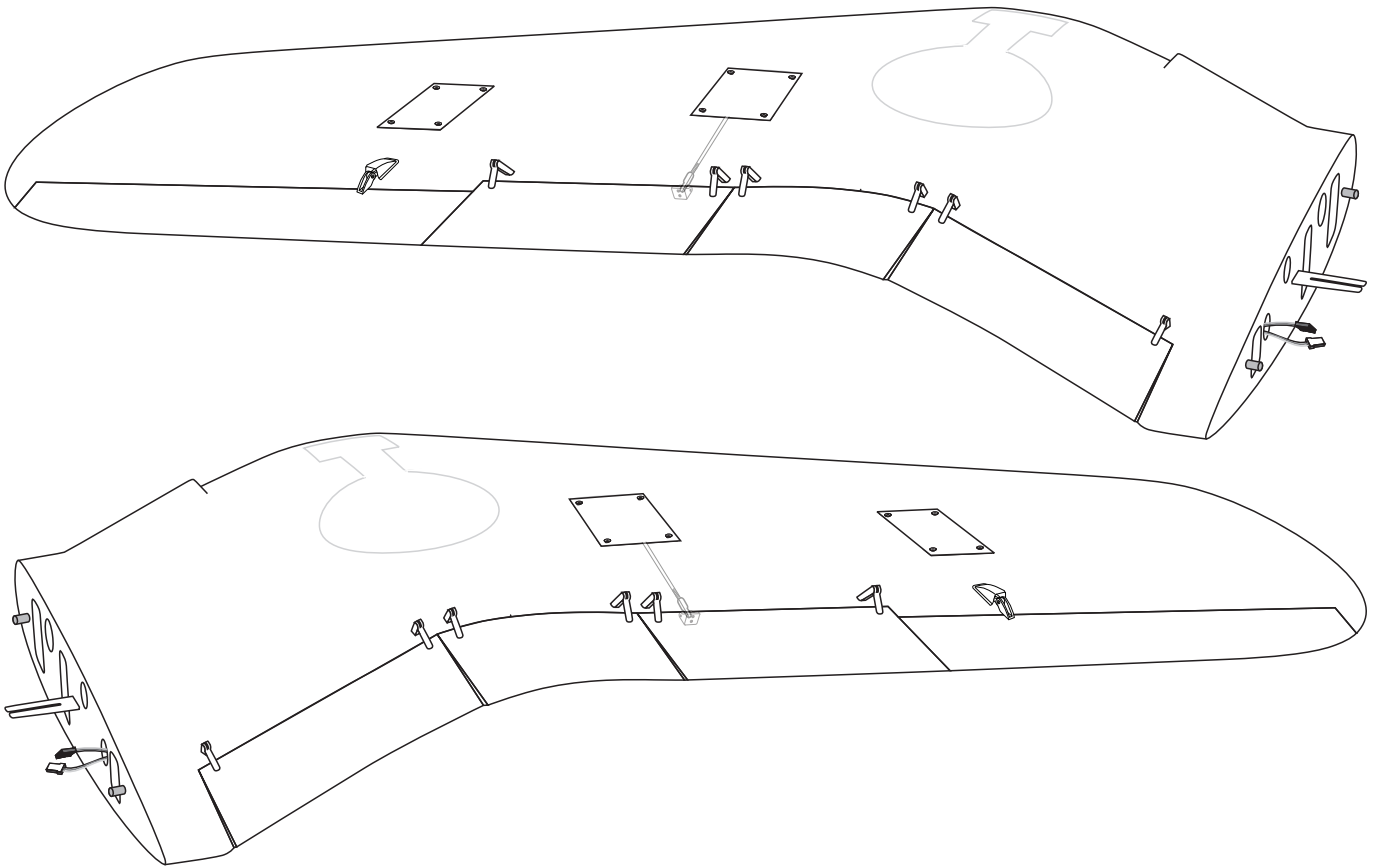

**INSTALLING THE ELECTRIC LANDING GEAR**

6x65mm Socket Head Cap Screw	4x20mm Socket Head Cap Screw
----- 2	----- 8
6mm Flat washer	4mm Spring Washer
----- 4	----- 8
	4mm Flat washer
	----- 8
6mm Collar -- 2	2x10 mm Tp Screw
	----- 2

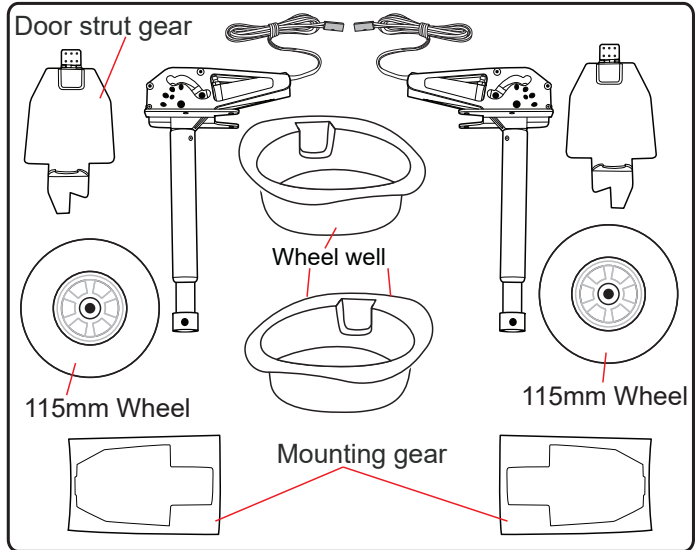

\* Using a modeling knife, carefully remove the film covering from the wing gear tray. Make sure that you do not remove any wood.

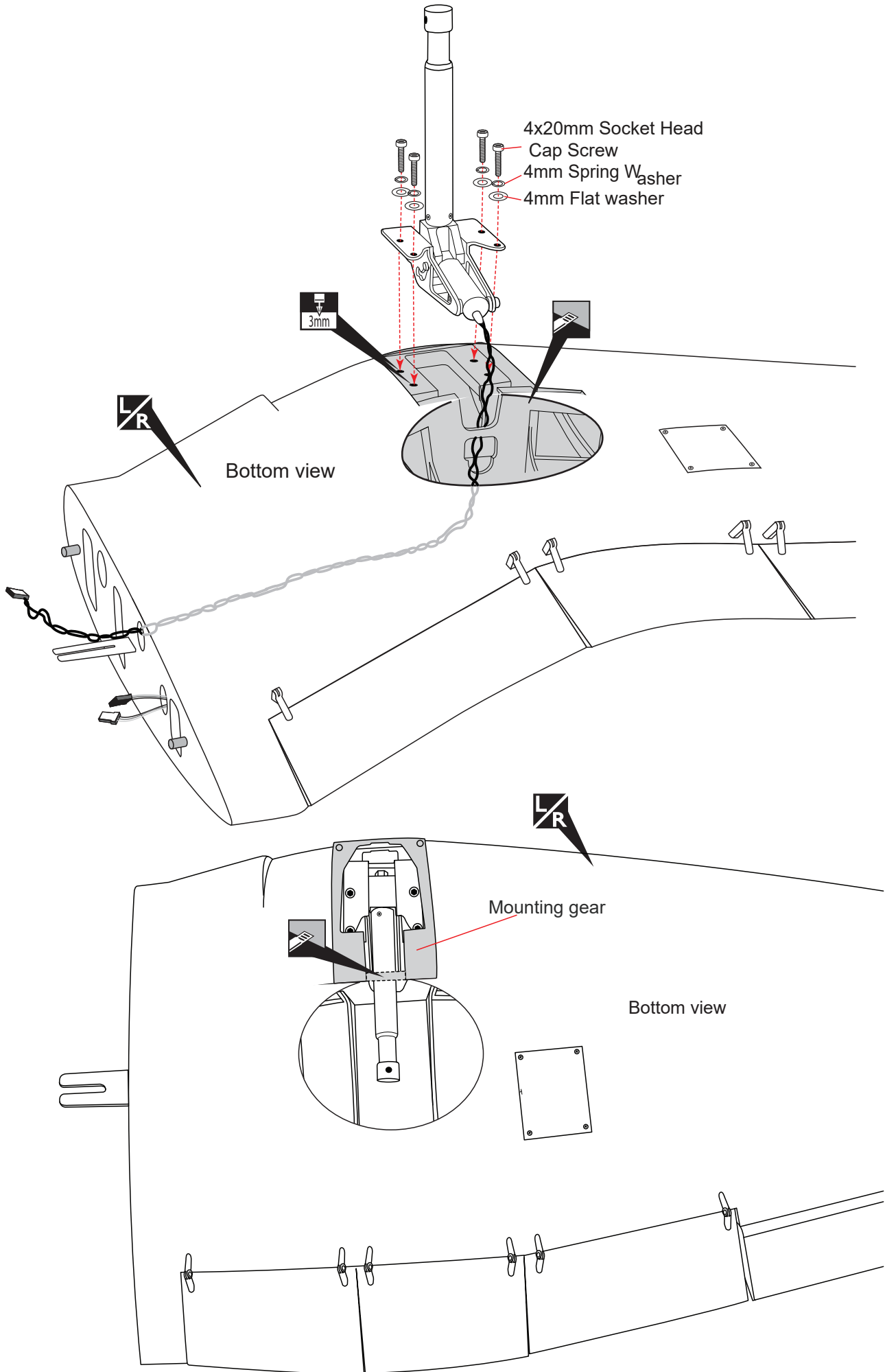

- 4x20mm Socket Head Cap Screw
- 4mm Spring Washer
- 4mm Flat washer

3mm

L/R

Bottom view

L/R

Mounting gear

Bottom view

 Cut off shaded portion carefully.

 Assemble left and right sides the same way.

 Drill holes using the stated. (in this case 3mm Ø).

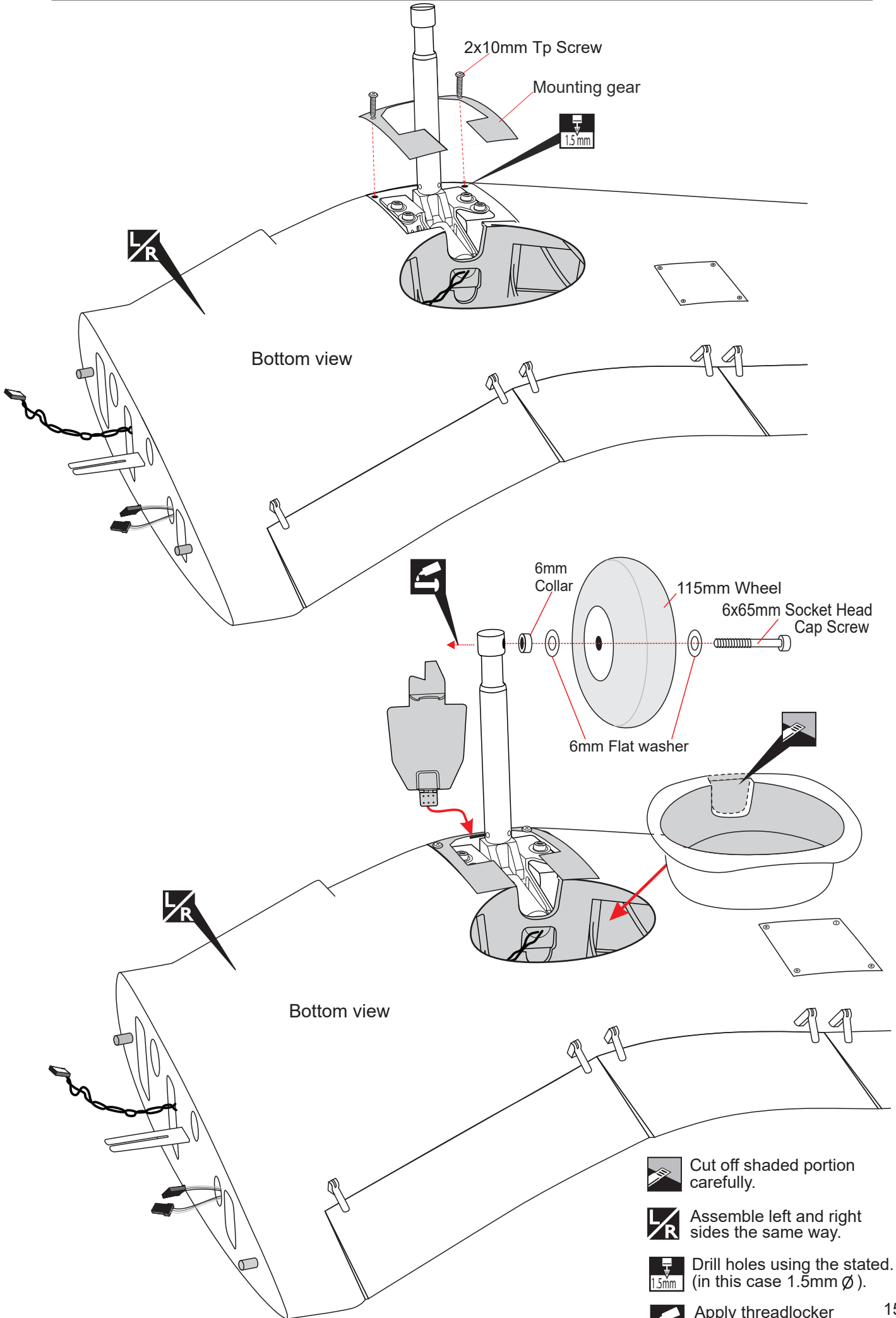

2x10mm Tp Screw

Mounting gear

1.5mm

Bottom view

6mm Collar

115mm Wheel

6x65mm Socket Head Cap Screw

6mm Flat washer

Bottom view

Cut off shaded portion carefully.

L/R Assemble left and right sides the same way.

1.5mm Drill holes using the stated. (in this case 1.5mm Ø).

Apply threadlocker (screw cement).

 Cut off shaded portion carefully.

 Apply instant glue (C.A glue, super glue).

 Assemble left and right sides the same way.

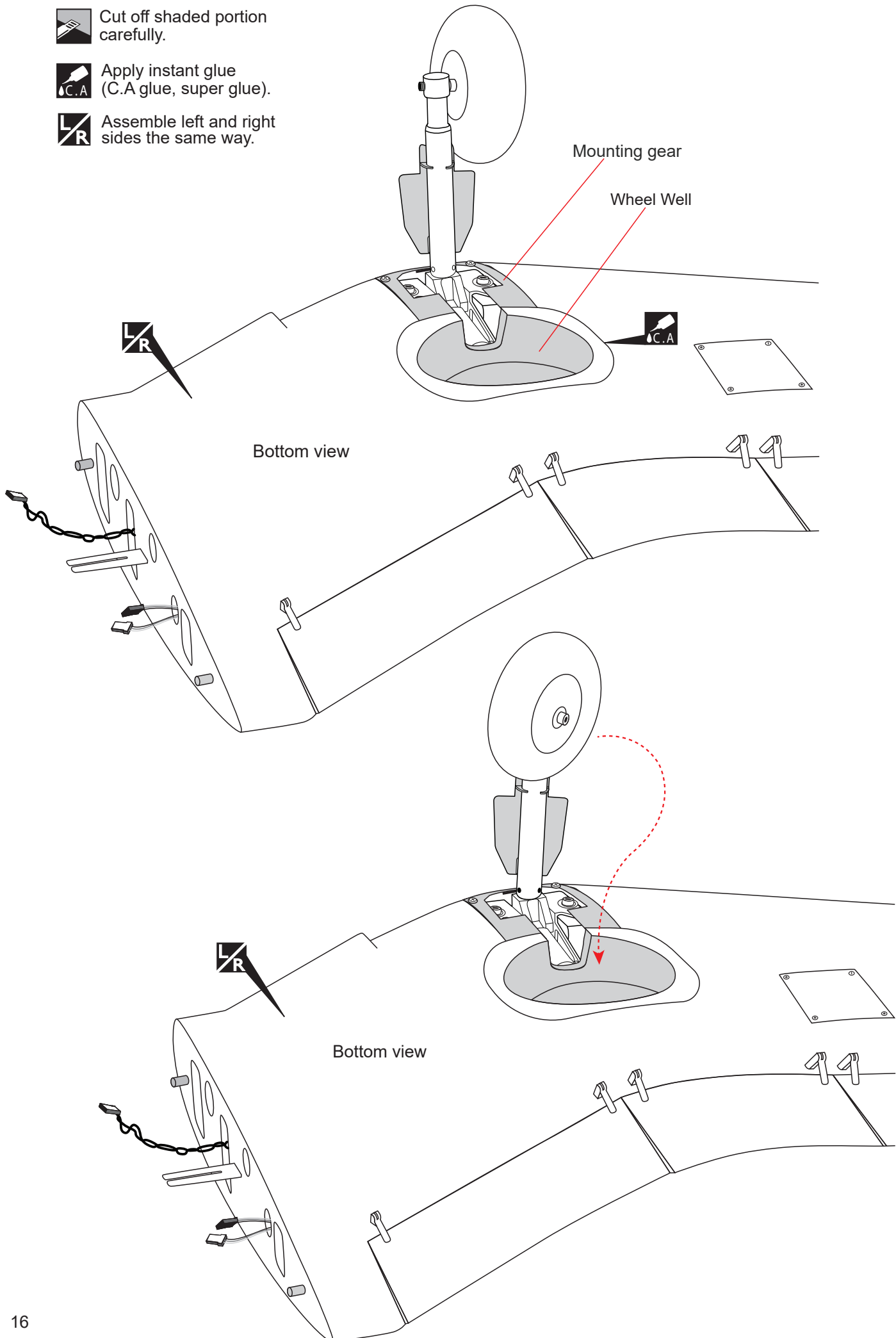



### ELECTRIC RETRACT SYSTEM

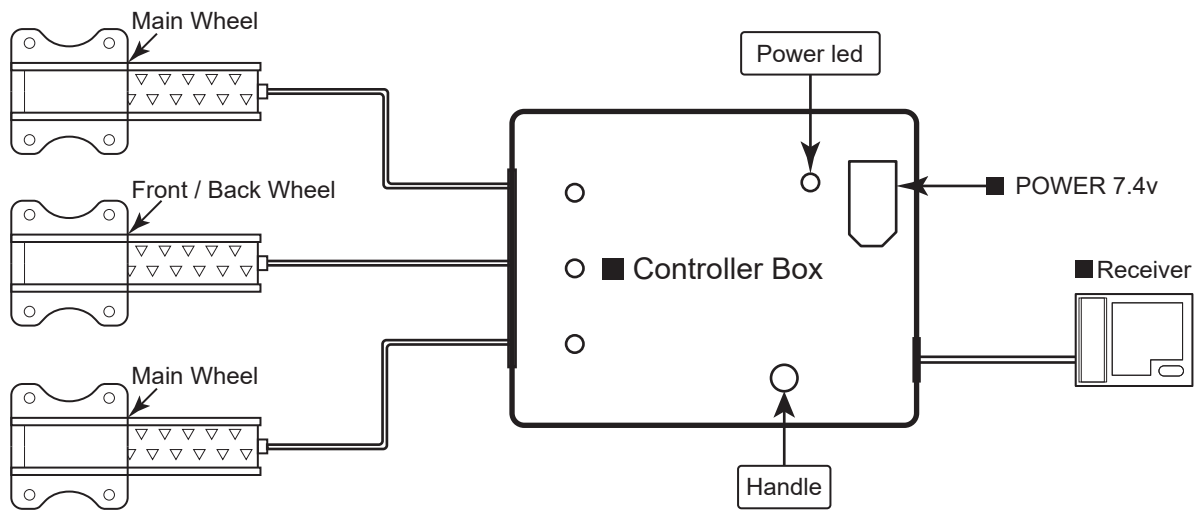

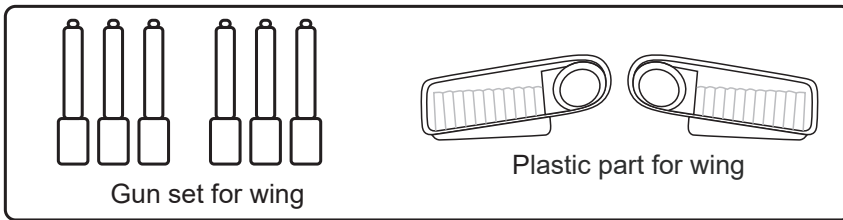
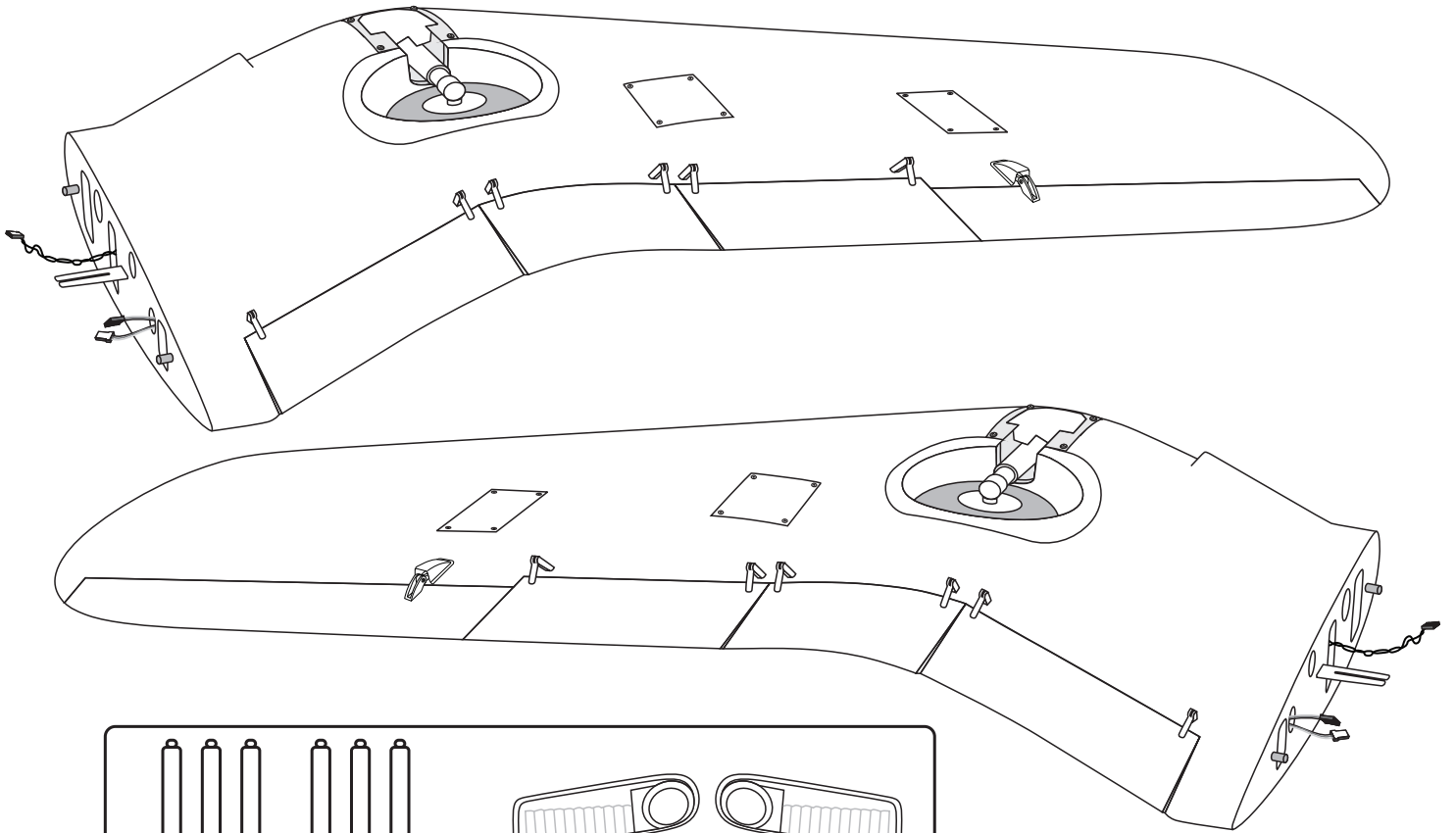

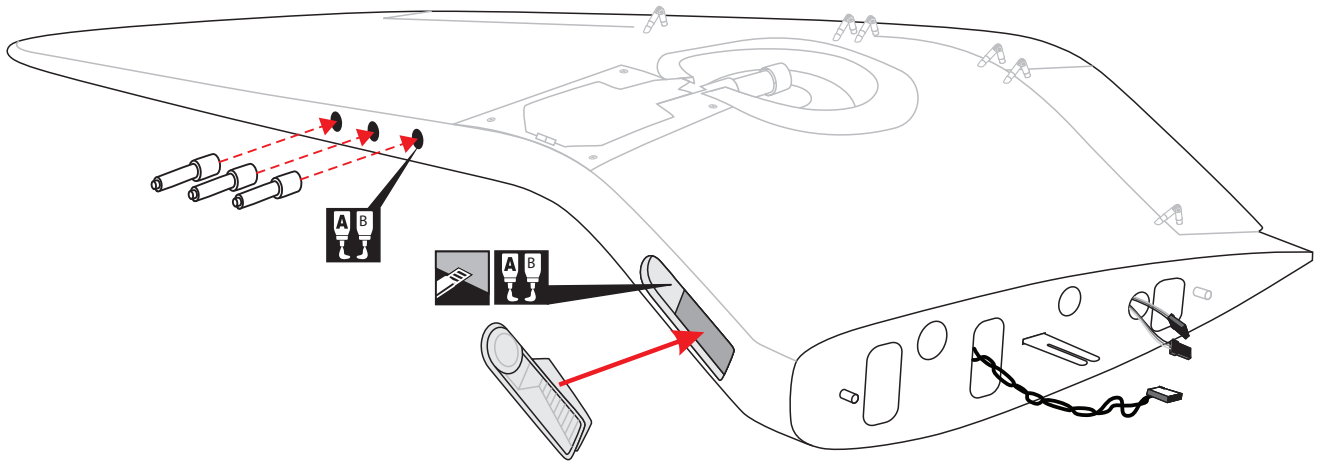

Bottom view

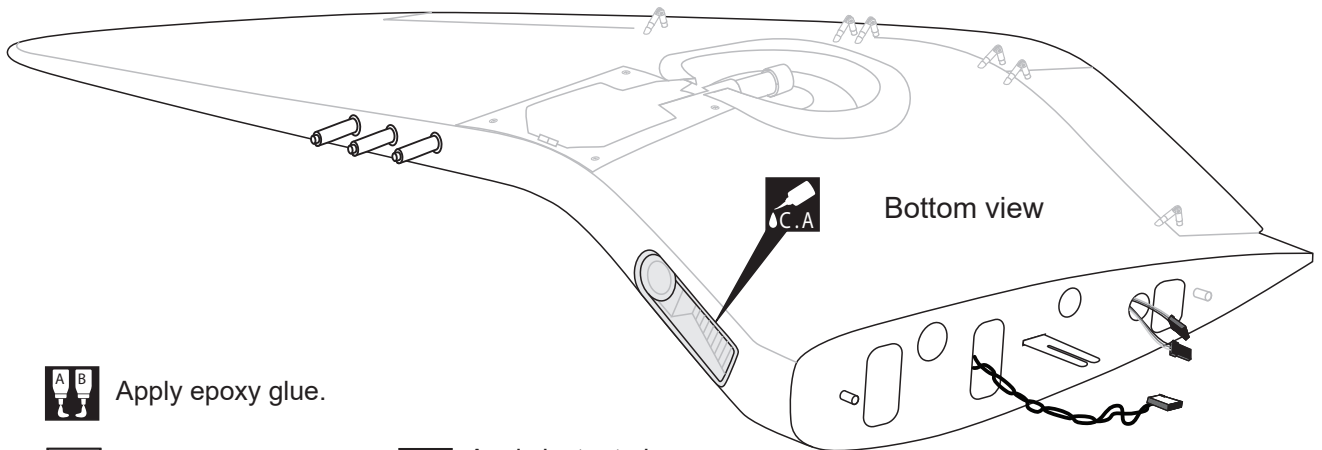

Bottom view



 Apply epoxy glue.

 Cut off shaded portion carefully.

 Apply instant glue (C.A glue, super glue).

### INSTALLING THE ENGINE MOUNT

Using plate of plywood (supplied with the kit) mark the holes onto the fire wall for installing the engine mount for DLE-55CC or OS-60CC.

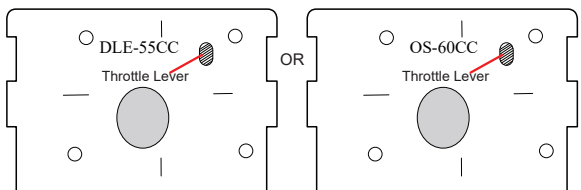

Maybe you also need to trim some wood from the tri-angle wood for the installation is easy

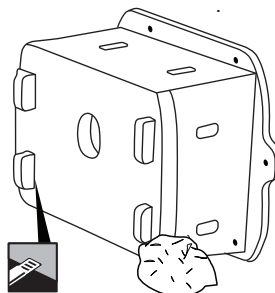



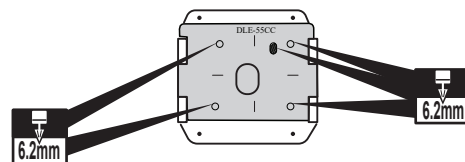
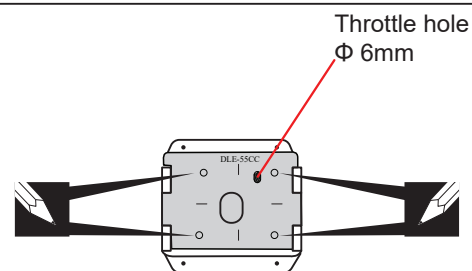
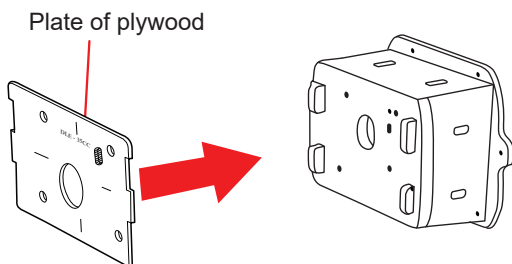



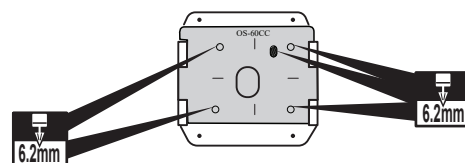
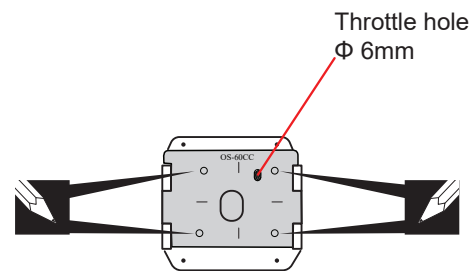
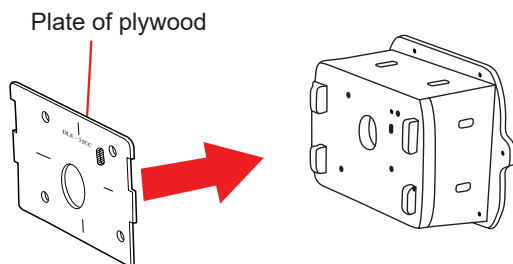

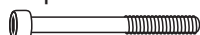

### DLE-55CC

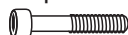

### OS-60CC

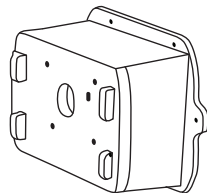

**INSTALLING THE ENGINE**

5x100mm Socket Head Cap Screw  -- 4	500mm Pushrod wire  --- 1	5x16mm Plastic Washer  --- 4	5mm Lock Nut  --- 6
5x25mm Socket Head Cap Screw  --- 6	12x65mm Aluminium  --- 4	Connector  --- 1	 --- 1
5mm Flat washer  --- 14	5mm Spring Washer  --- 10	5mm Flat washer  --- 6	

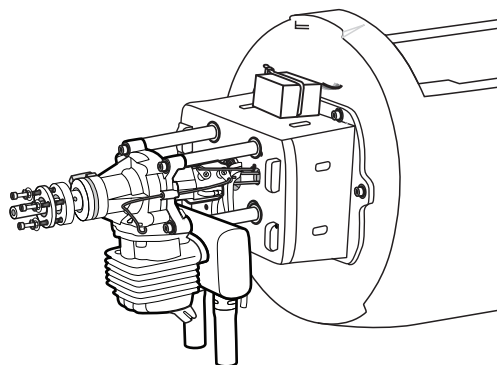
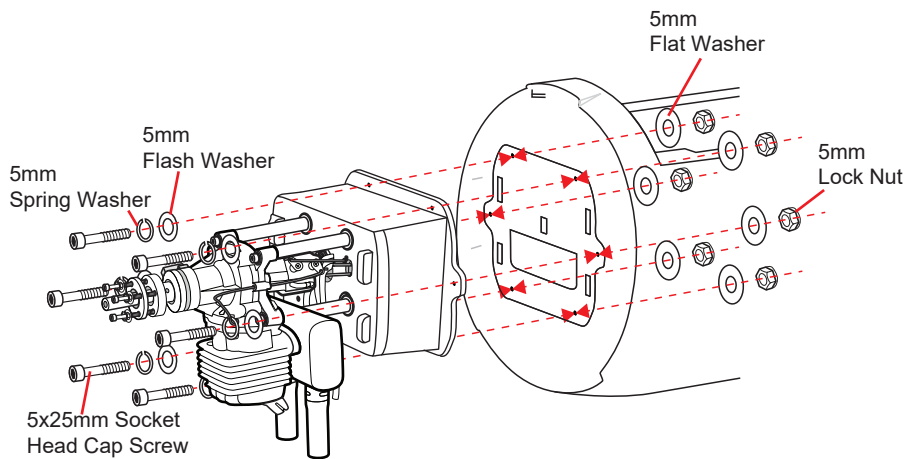
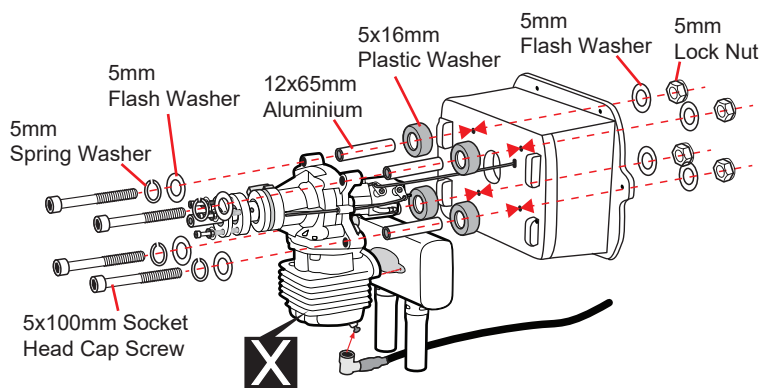

Apply threadlocker (screw cement).



Must be purchased separately!



Apply threadlocker (screw cement).



Ensure smooth, non-binding movement when assembling.

## INSTALLING THE FUEL TANK.

1) The stopper has been pre-assembled at the factory.

2) Using a modeling knife, cut one length of silicon fuel line (the length of silicon fuel line is calculated by how the weighted clunk should rest about 8mm away from the rear of the tank and move freely inside the tank). Connect one end of the line to the weighted clunk and the other end to the nylon pick up tube in the stopper.

3) Carefully bend the second nylon tube up at a 45 degree angle (using a cigarette lighter). This tube will be the vent tube to the muffler.

4) Carefully bend the third nylon tube down at a 45 degree angle (using a cigarette lighter). This tube will be vent tube to the fueling valve.

 When the stopper assembly is installed in the tank, the top of the vent tube should rest just below the top surface of the tank. It should not touch the top of the tank.

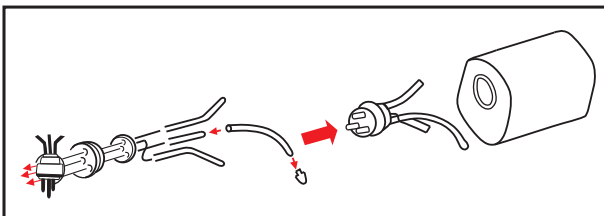

 Do not secure the tank into place permanently until after balancing the airplane. You may need to remove the tank to mount the battery in the fuel tank compartment.

9. Secure the fuel tank.

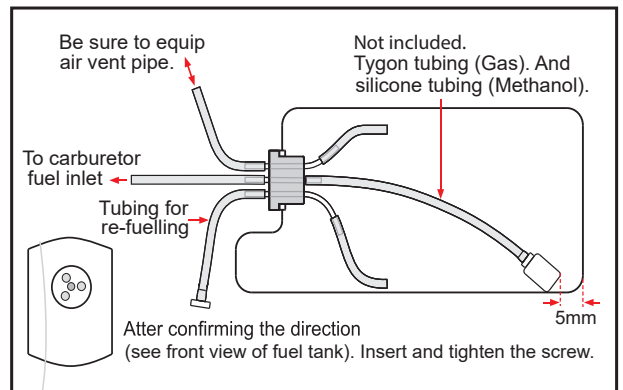
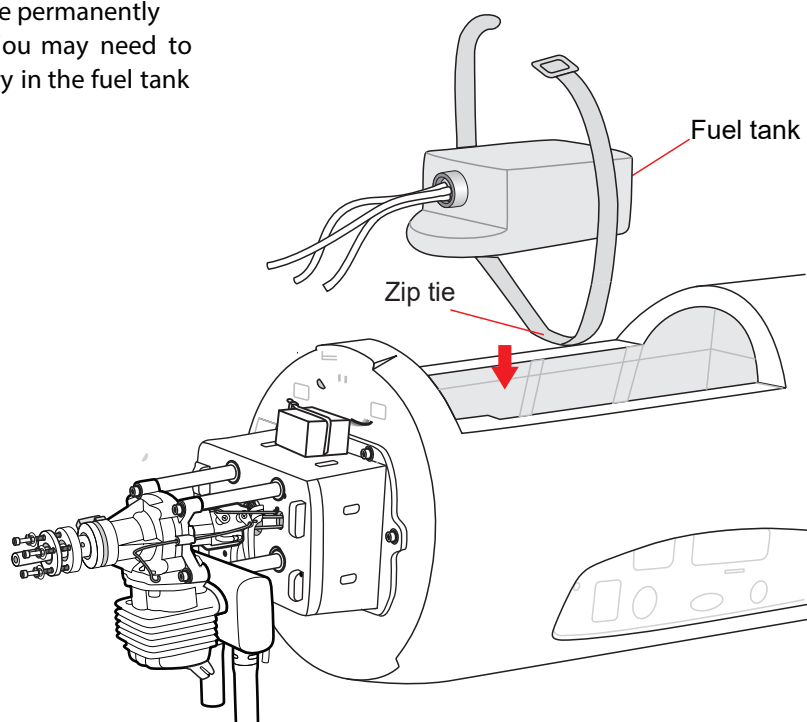
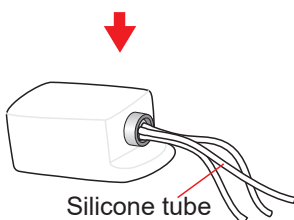
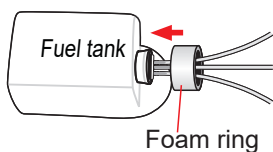

5) Test fit the stopper assembly into the tank. It may be necessary to remove some of the flashing around the tank opening using a modeling knife. If flashing is present, make sure none of it falls into the tank.

6) When satisfied with the alignment of the stopper assembly tighten the 3mm x 20mm machine screw until the rubber stopper expands and seals the tank opening. Do not over tighten the assembly as this could cause the tank to split.

7) Using a modeling knife, cut 3 lengths of fuel line. Connect 2 lines to the 2 vent tubes and 1 line to the fuel pickup tube in the stopper.

8) Feed three lines through the fuel tank compartment and through the pre-drilled hole in the firewall. Pull the lines out from behind the engine, while guiding the fuel tank into place. Push the fuel tank as far forward as possible, the front of the tank should just about touch the back of the firewall. Blow through one of the lines to ensure the fuel lines have not become kinked inside the fuel tank compartment. Air should flow through easily.

**INSTALLING THE FUSELAGE SERVOS**

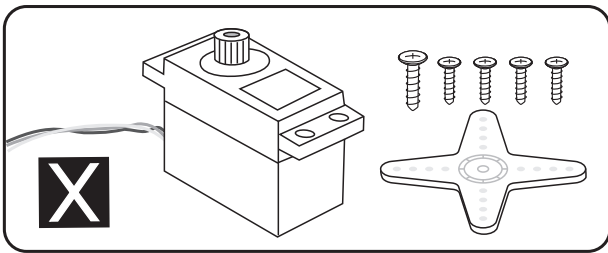

1) Install the rubber grommets and brass collets into the elevator, rudder and throttle servos. Test fit servos into the servo tray. Trim the tray if necessary fit your servos.

2) Mount the servo to the tray using the mounting screws provided with your radio system.

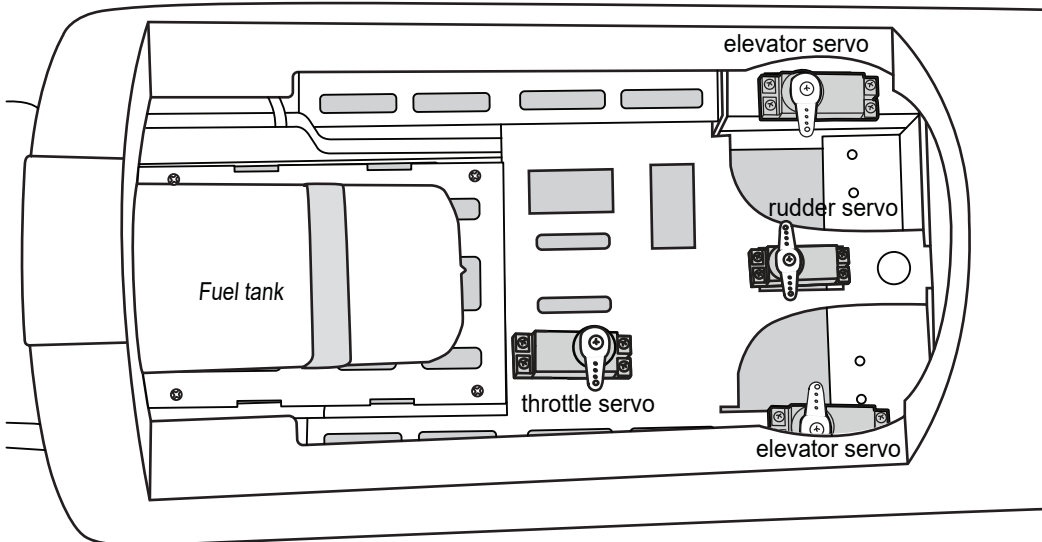
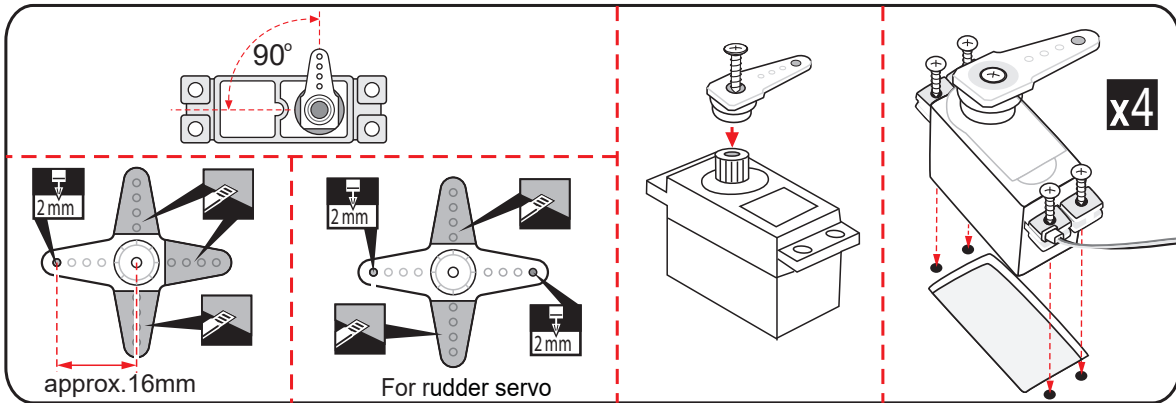

- Cut off shaded portion carefully.
- Must be purchased separately.
- Drill holes using the stated. (in this case 1.5mm Ø).
- The number of times the same way Assembly (in this case twice).

**INSTALLING THE THROTTLE**

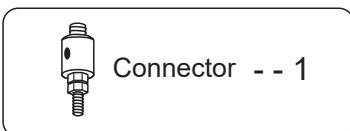

1) Install one adjustable metal connector through the third hole out from the center of one servo arm, enlarge the hole in the servo arm using a 2mm drill bit to accommodate the servo connector. Remove the excess material from the arm.

After installing the adjustable metal connector apply a small drop of thin C/A to the bottom nut. This will prevent the connector from loosening during flight.

2) Plug the throttle servo into the receiver and turn on the radio system. Check to ensure that the throttle servo output shaft is moving in the correct

direction. When the throttle stick is moved forward from idle to full throttle, the throttle barrel should also open and close using this motion. If not, reverse the direction of the servo, using the transmitter.

3) Slide the adjustable metal connector / servo arm assembly over the plain end of the pushrod wire. Position the throttle stick and the throttle trim at their lowest positions.

4) Manually push the carburetor barrel fully closed. Angle the arm back about 45 degree from center and attach the servo arm onto the servo. With the carburetor barrel fully closed, tighte the set screw in the adjustable metal connector.

5) Remove the excess throttle pushrod wire using wire cutters and install the servo arm retaining screw.

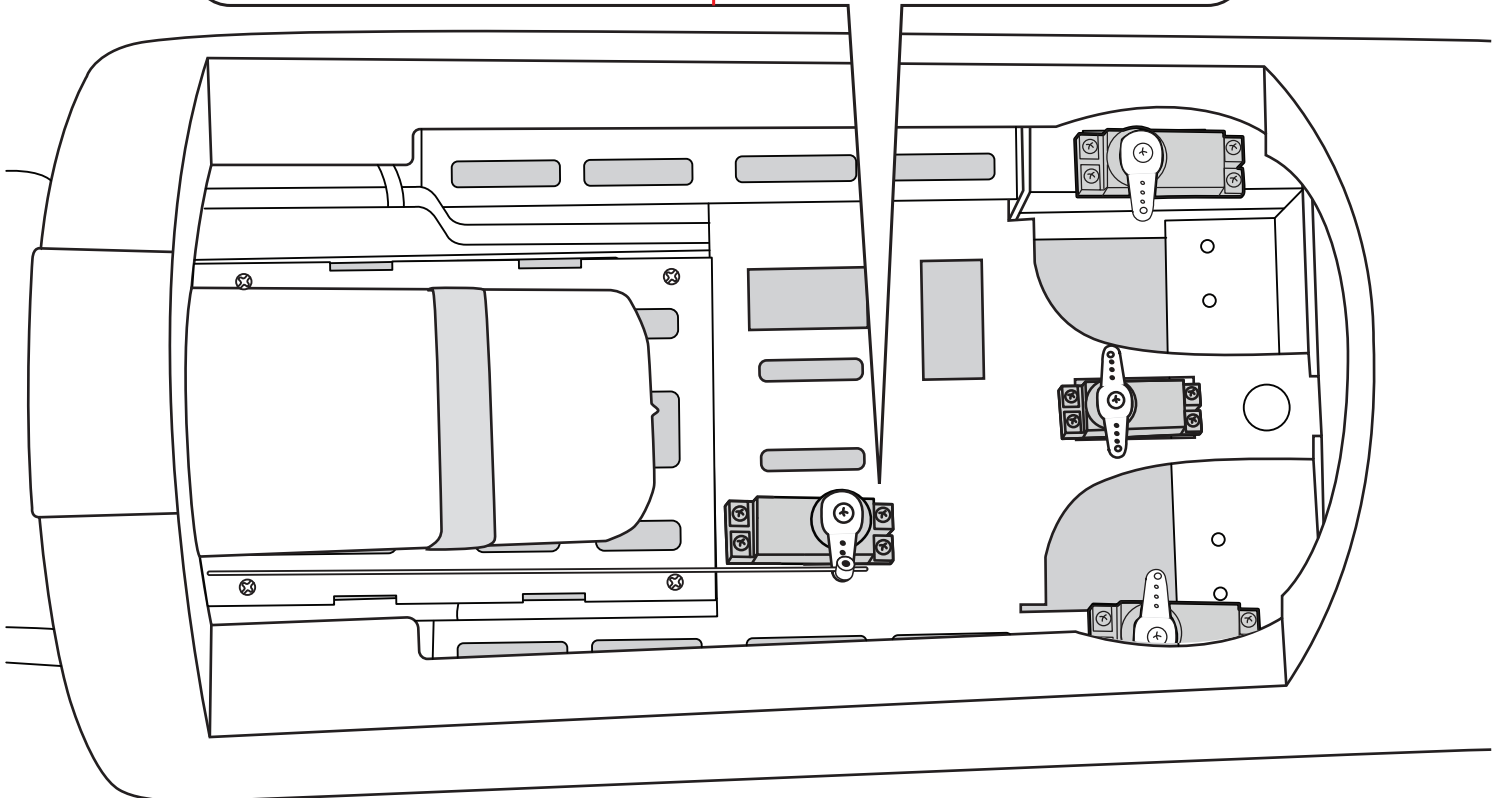
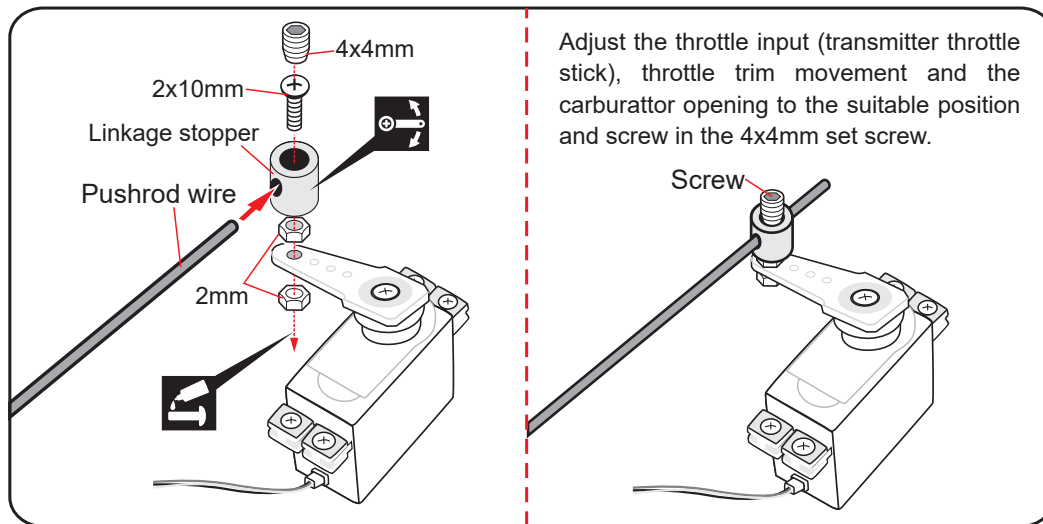

## MOUNTING THE COWL

- 1) Remove the muffler and needle valve assembly from the engine. Slide the fiberglass cowl over the engine.
- 2) Measure and mark the locations to be cut out for engine head clearance, needle valve, muffler. Remove the cowl and make these cutouts using a rotary tool with a cutting disc and a rotary sanding drum attachment.
- 3) Slide the cowl back into place. Align the front of the cowl with the crankshaft of the engine. The front of the cowl should be positioned so the crankshaft is in the middle of the precut opening. Hold the cowl firmly in place using several pieces of masking tape.

- 4) While holding the cowl firmly in position, drill four 1,6mm pilot holes through both the cowl and the side edges of the firewall.

- 5) Using a 3mm drill bit, enlarge the four holes in the cowling.

 Enlarging the holes through the cowl will prevent the fiberglass from splitting when the mounting screws are installed.

- 6) Slide the cowl back over the engine and secure it in place using four screws.



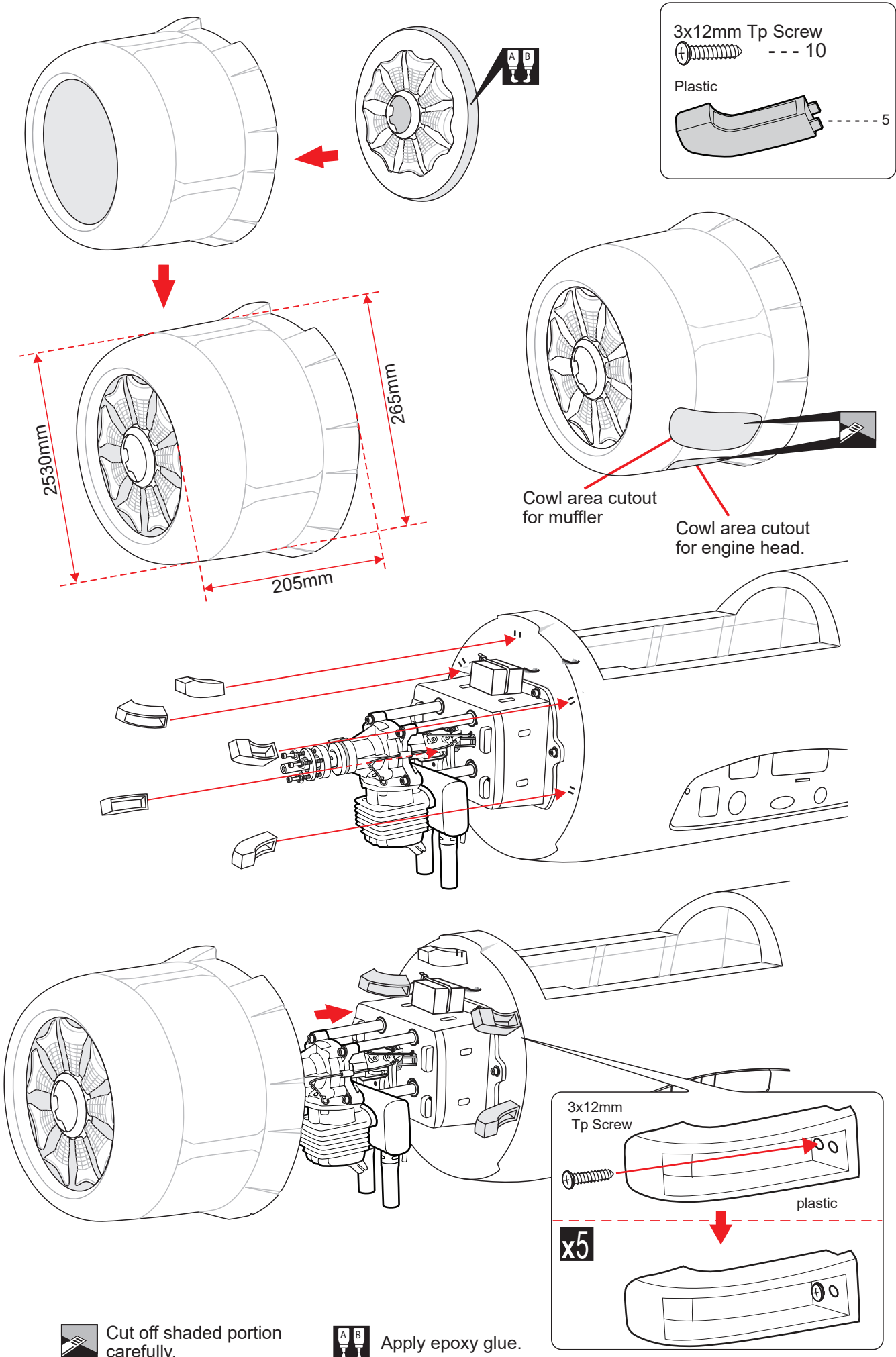

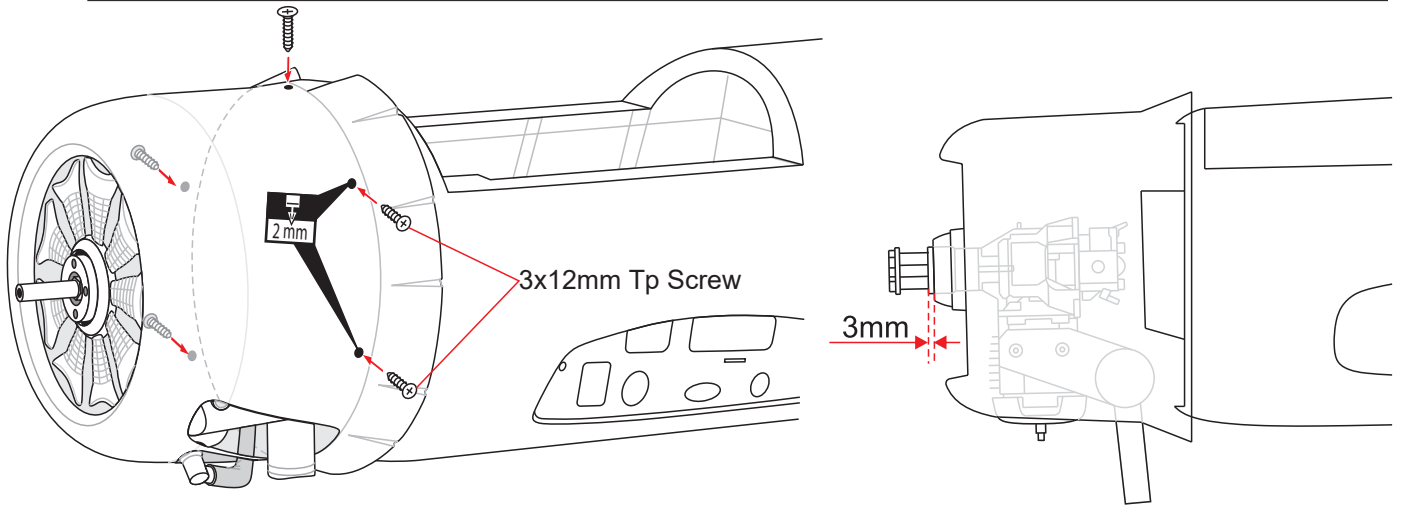

- 7) Install the muffler. Connect the fuel and pressure lines to the carburetor, muffler and fuel filler valve. Tighten the screws completely.



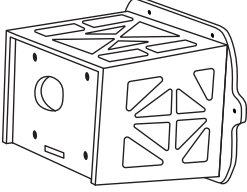

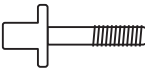

### INSTALLING THE ELECTRIC MOTOR (EP VERSION)

5x25mm Socket Head Cap Screw	5mm Spring Washer		6x25mm Plastic Screw
 --- 4	 --- 4		 --- 1
5mm Plastic Washer	5mm Lock Nut		
 --- 8	 --- 4		 --- 1

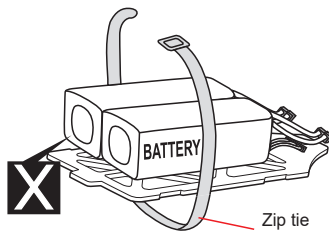
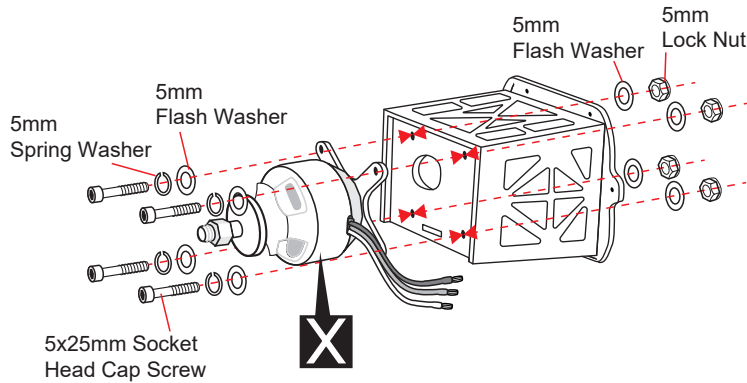

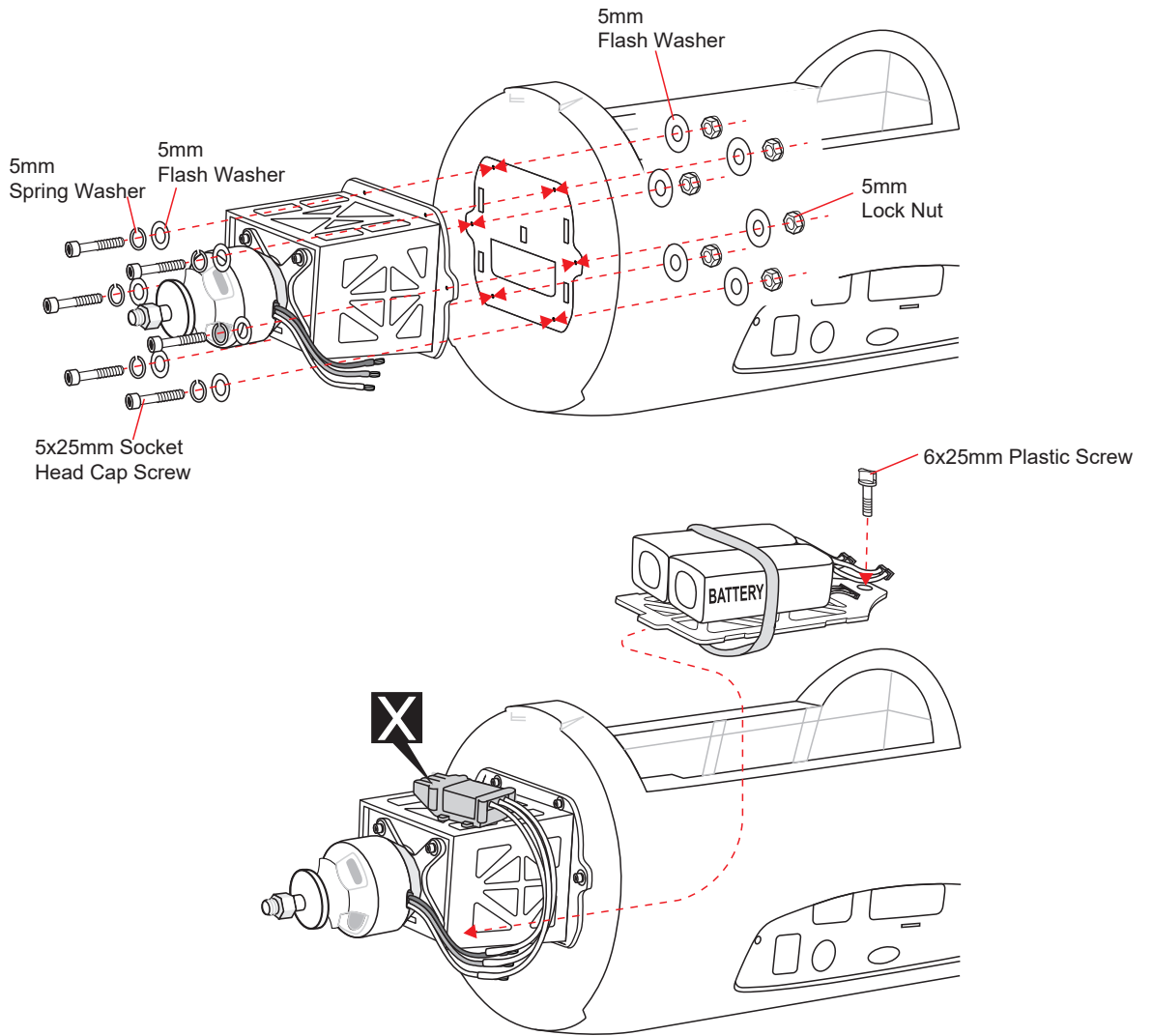

### INSTALLING VERTICAL STABILIZER

- 2.6x935mm Push rod --- 1
- 3x30mm Socket Head Cap Screw --- 1
- 3x12mm Button Head Cap Screw --- 2
- Horn --- 1
- Ball link --- 2
- 3mm Flat Washer --- 1
- 3mm Lock Nut --- 1
- 44mm Pinned Hinge --- 3

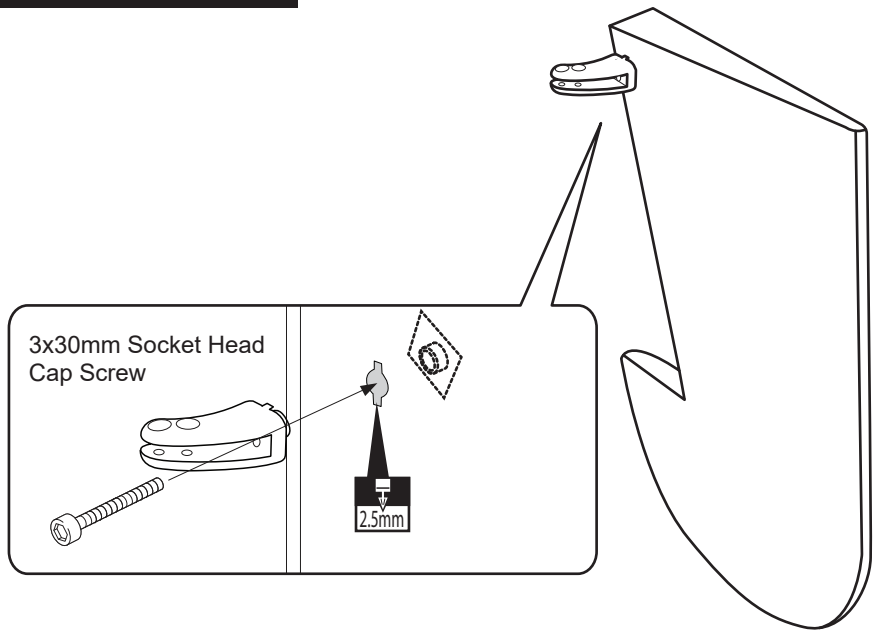



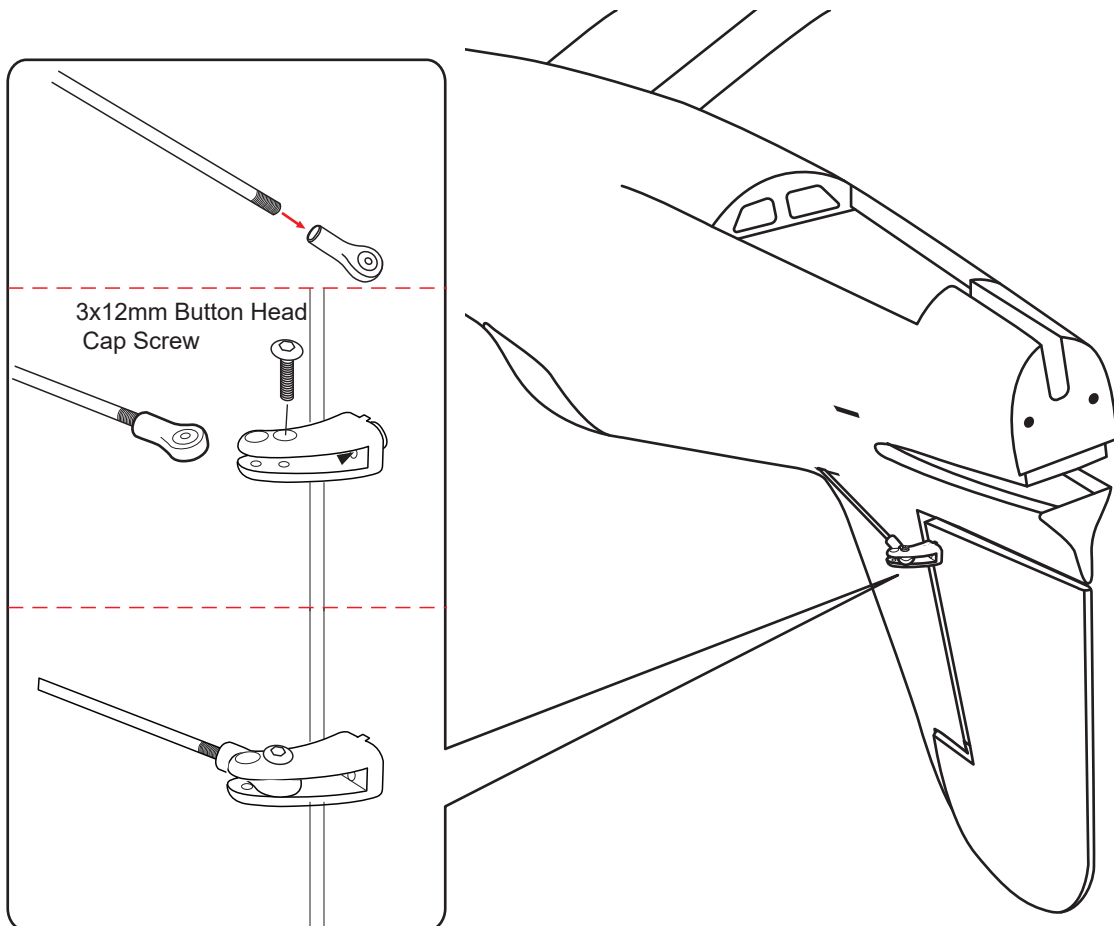
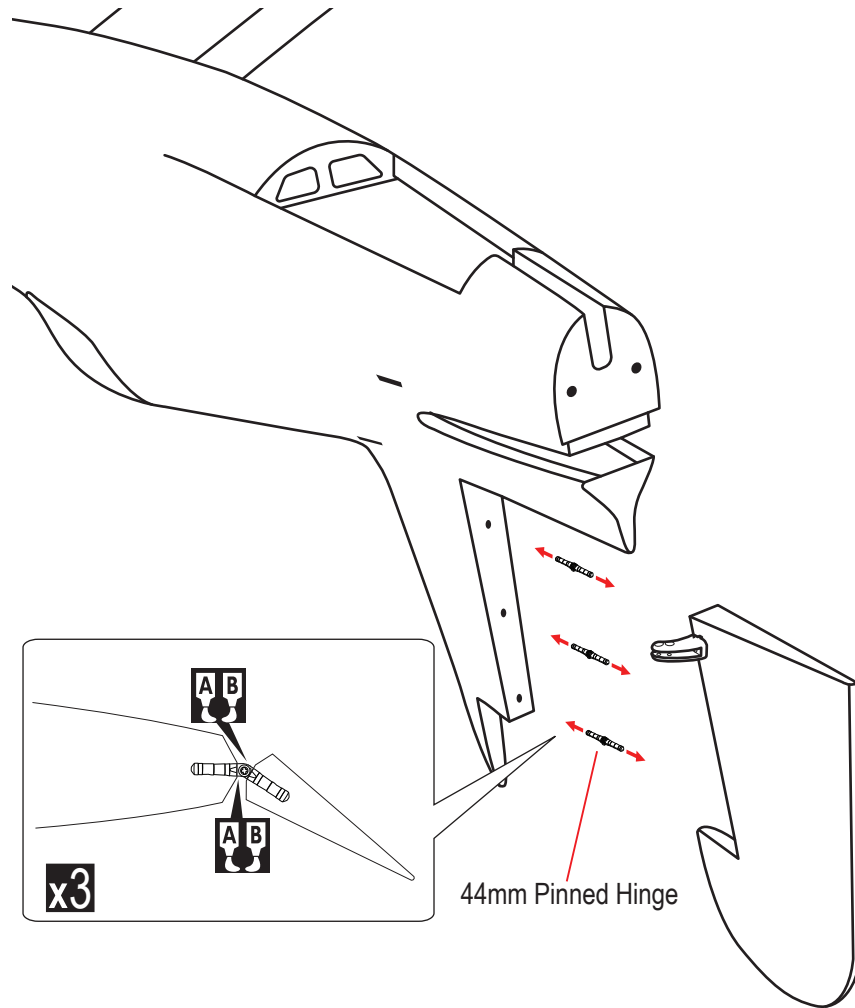



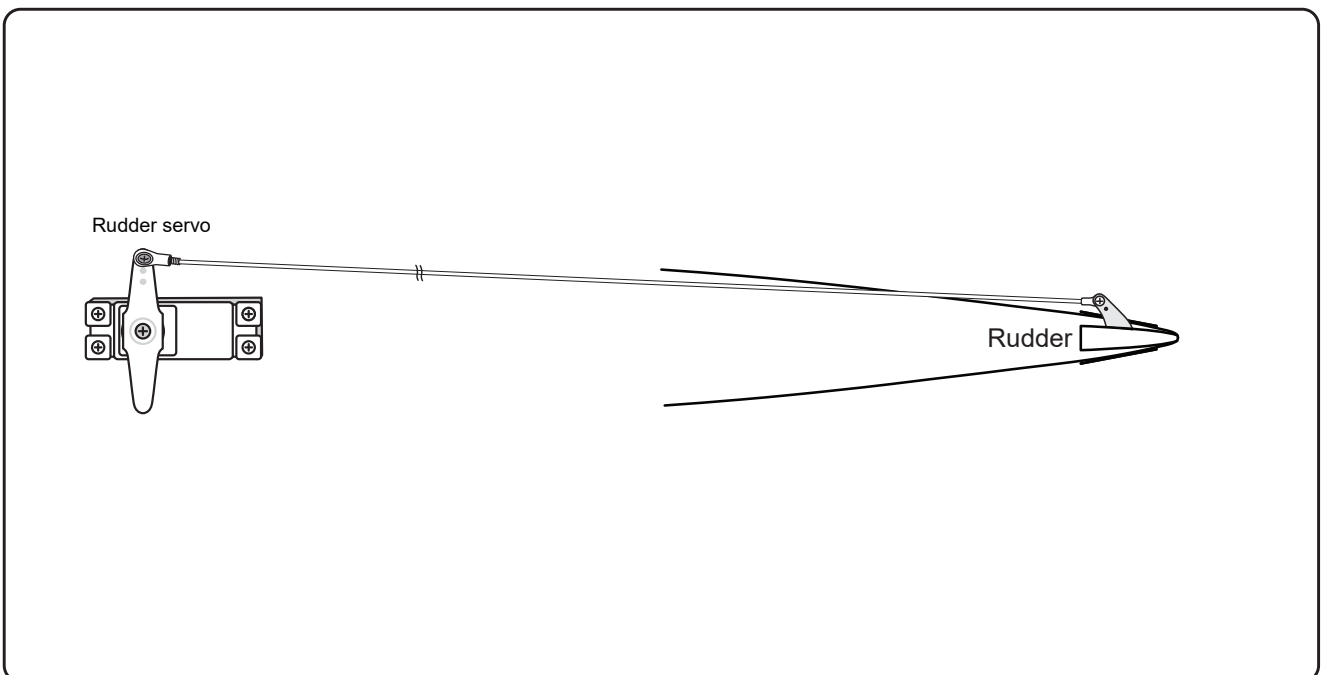
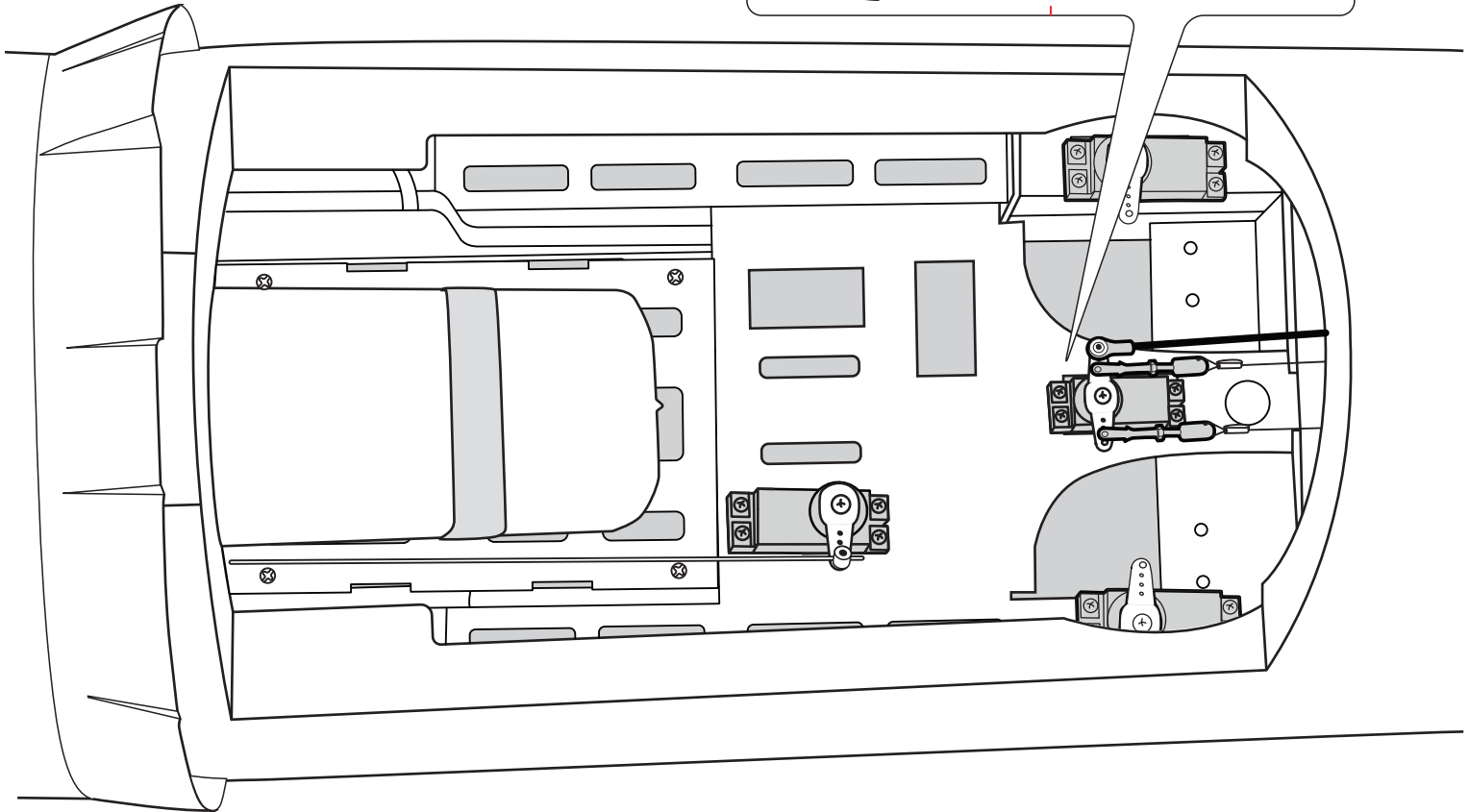
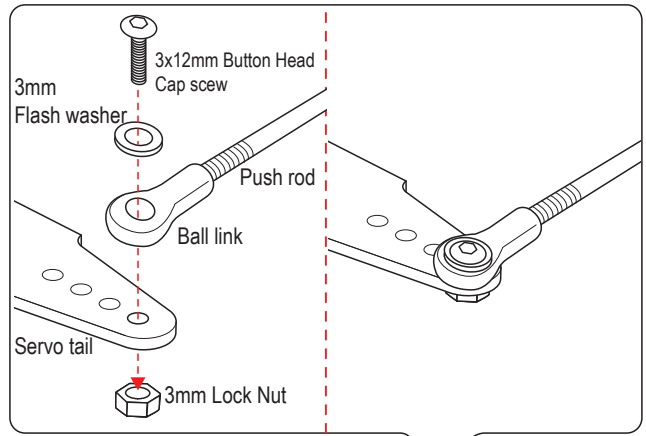

BOTTOM VIEW

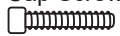

Fuselage top side



**INSTALLING HORIZONTAL STABILIZER**

2.6x1090mm Push rod  --- 2	 Ball link --- 4
3x25mm Socket Head Cap Screw  --- 2	3mm Flat Washer  --- 2
3x12mm ButtonHead Cap Screw  --- 4	3mm Lock Nut  --- 2
 Horn --- 2	44mm Pinned Hinge  --- 8

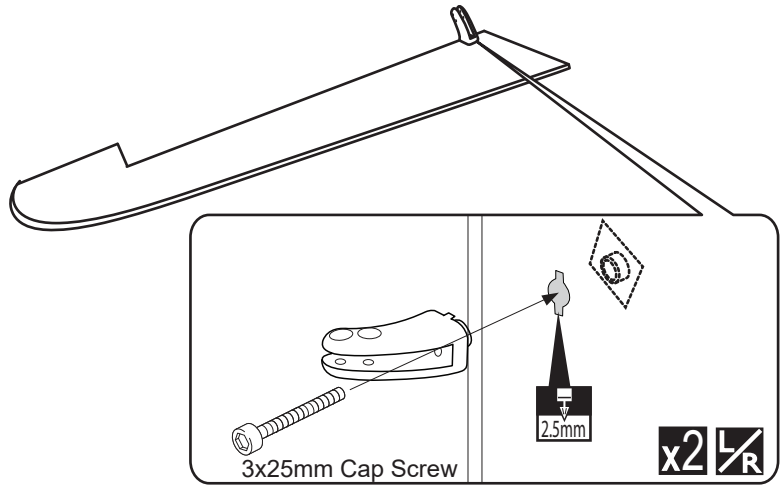

**BOTTOM VIEW**

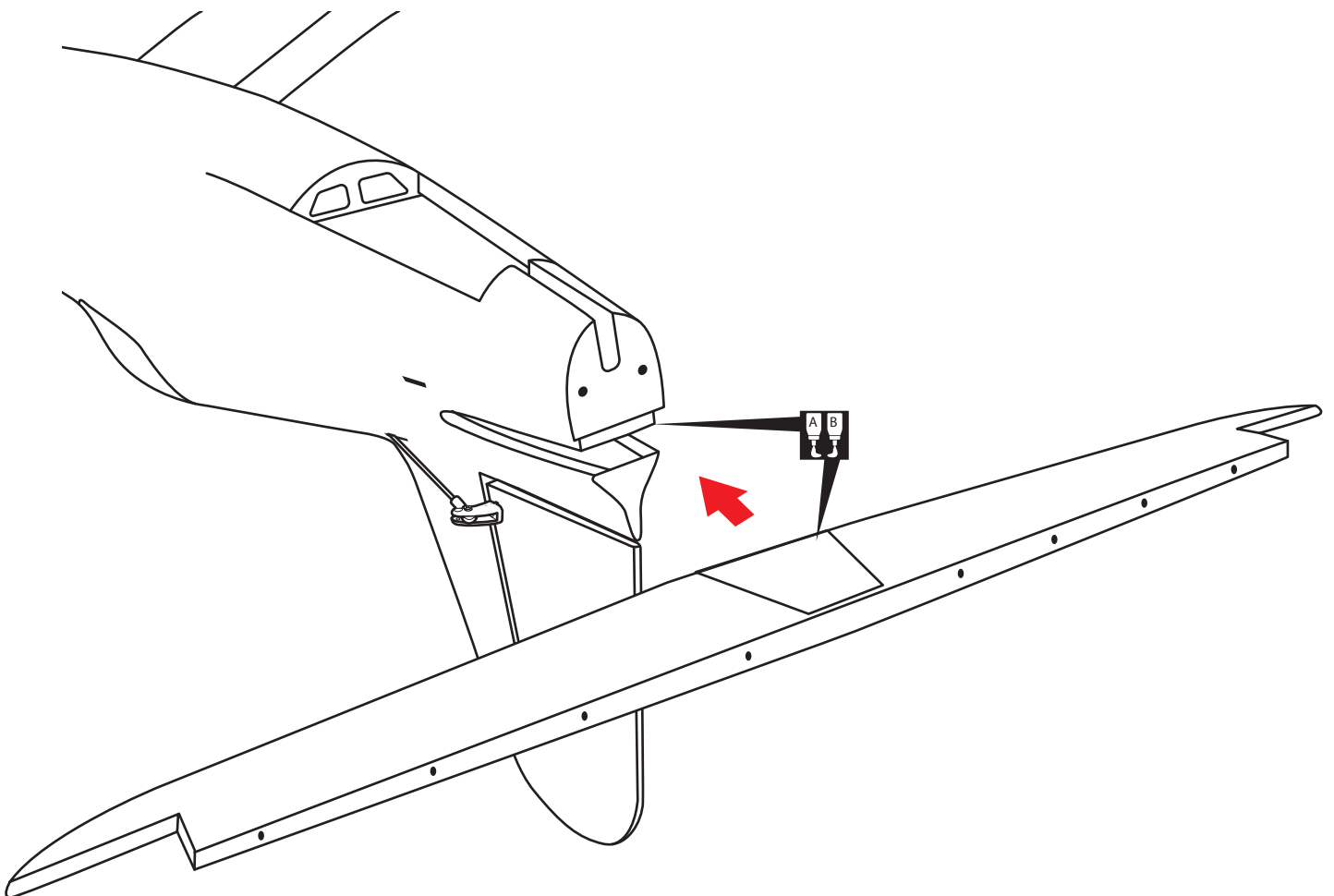

BOTTOM VIEW

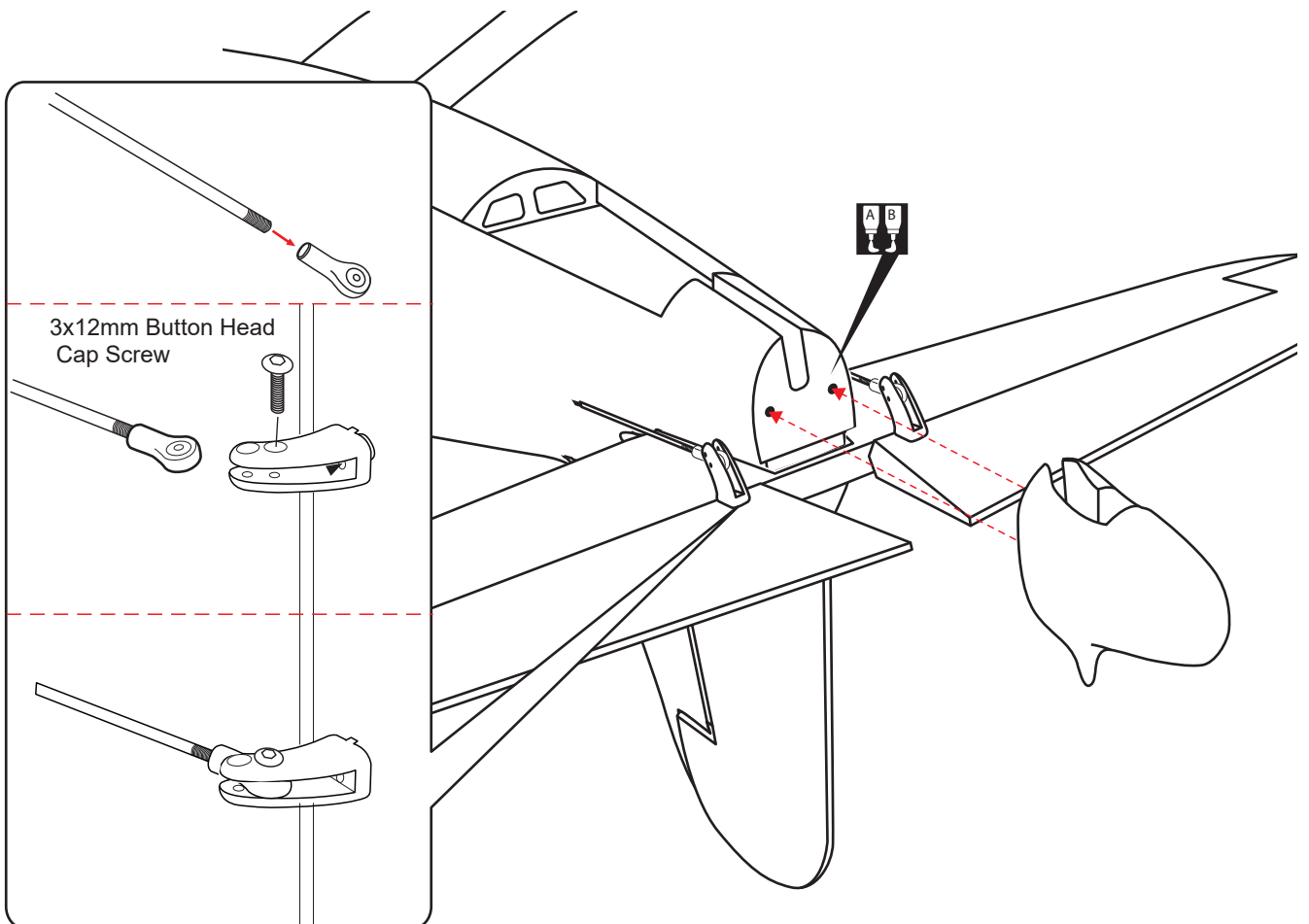
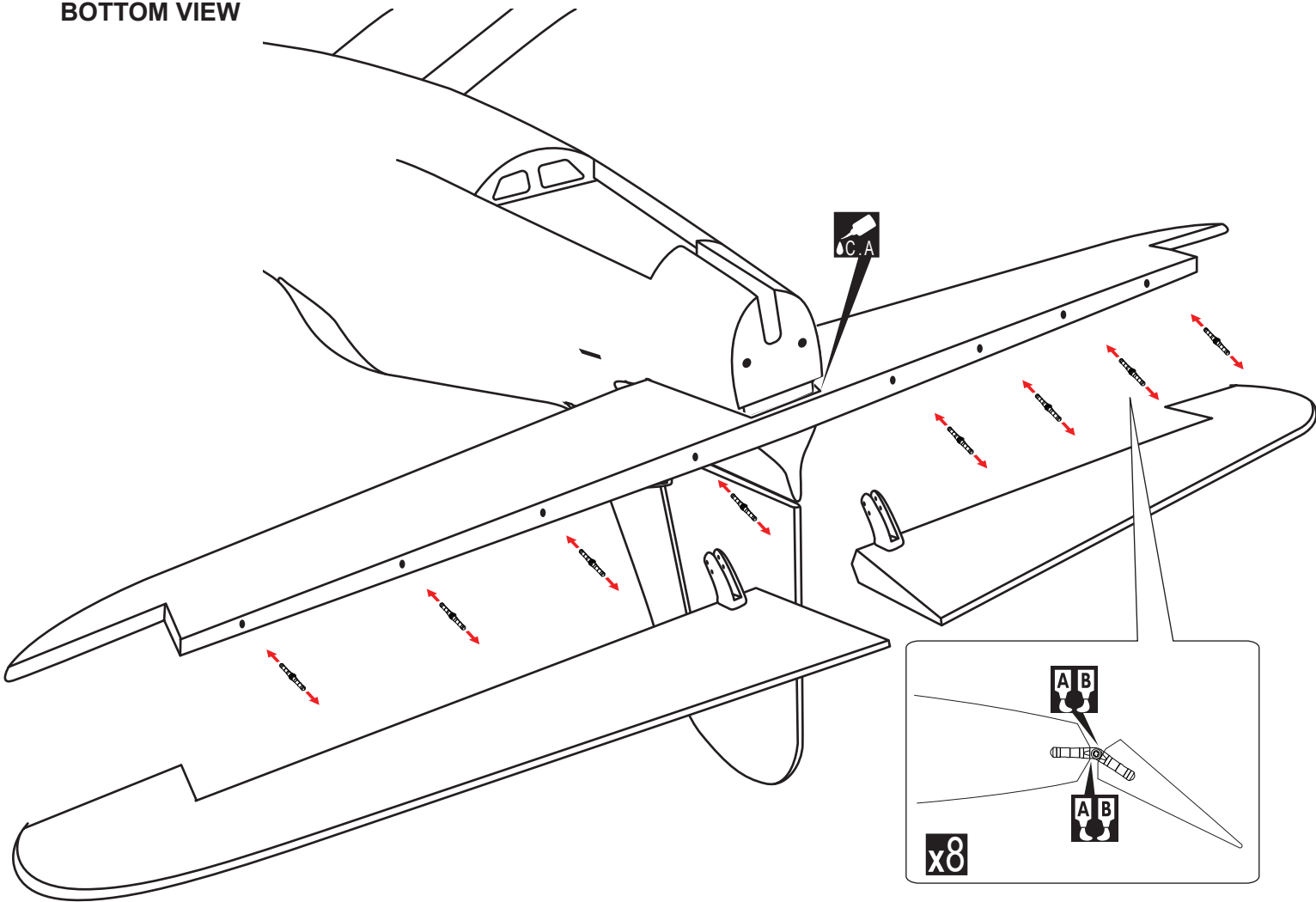

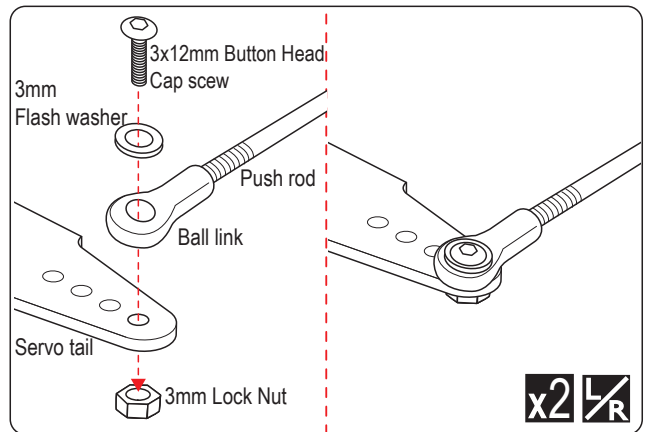
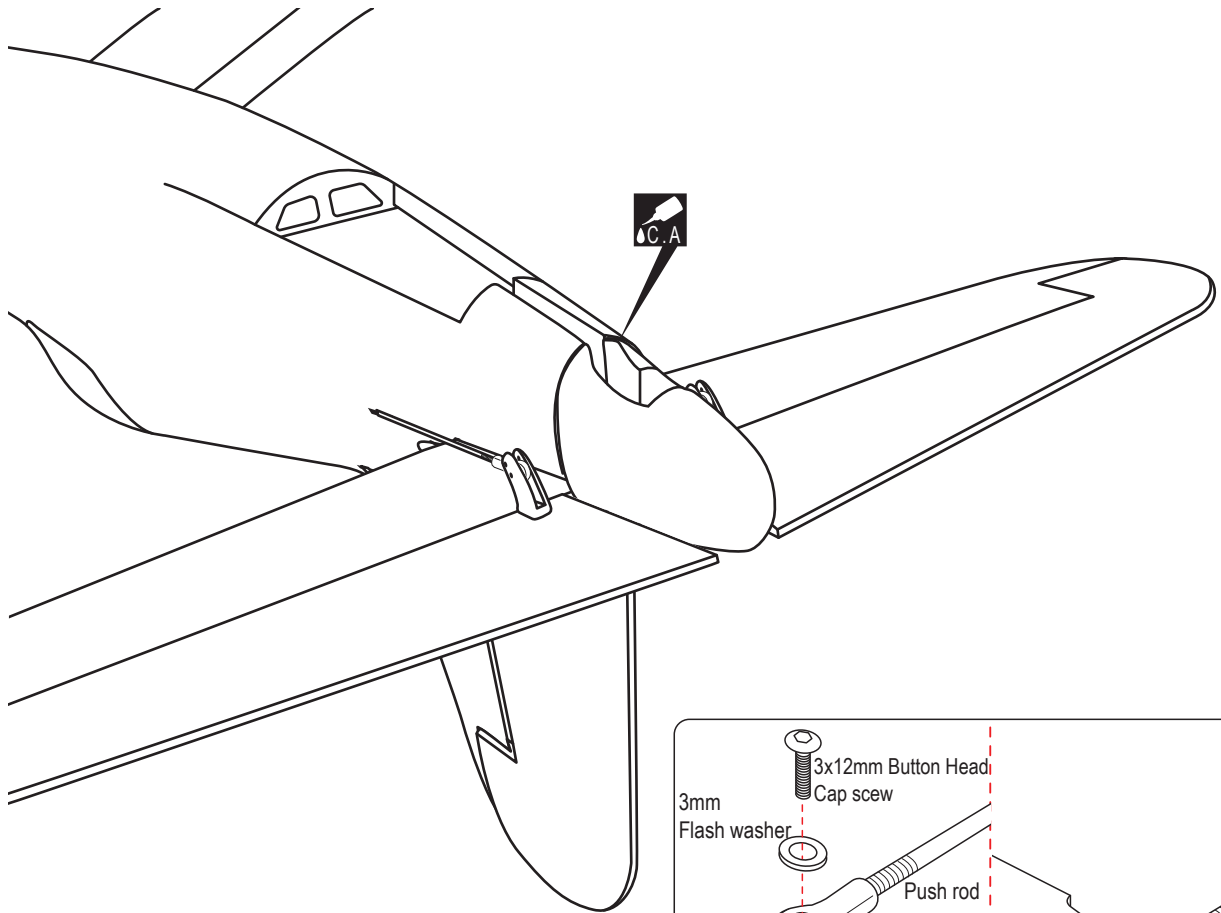

Fuselage top side

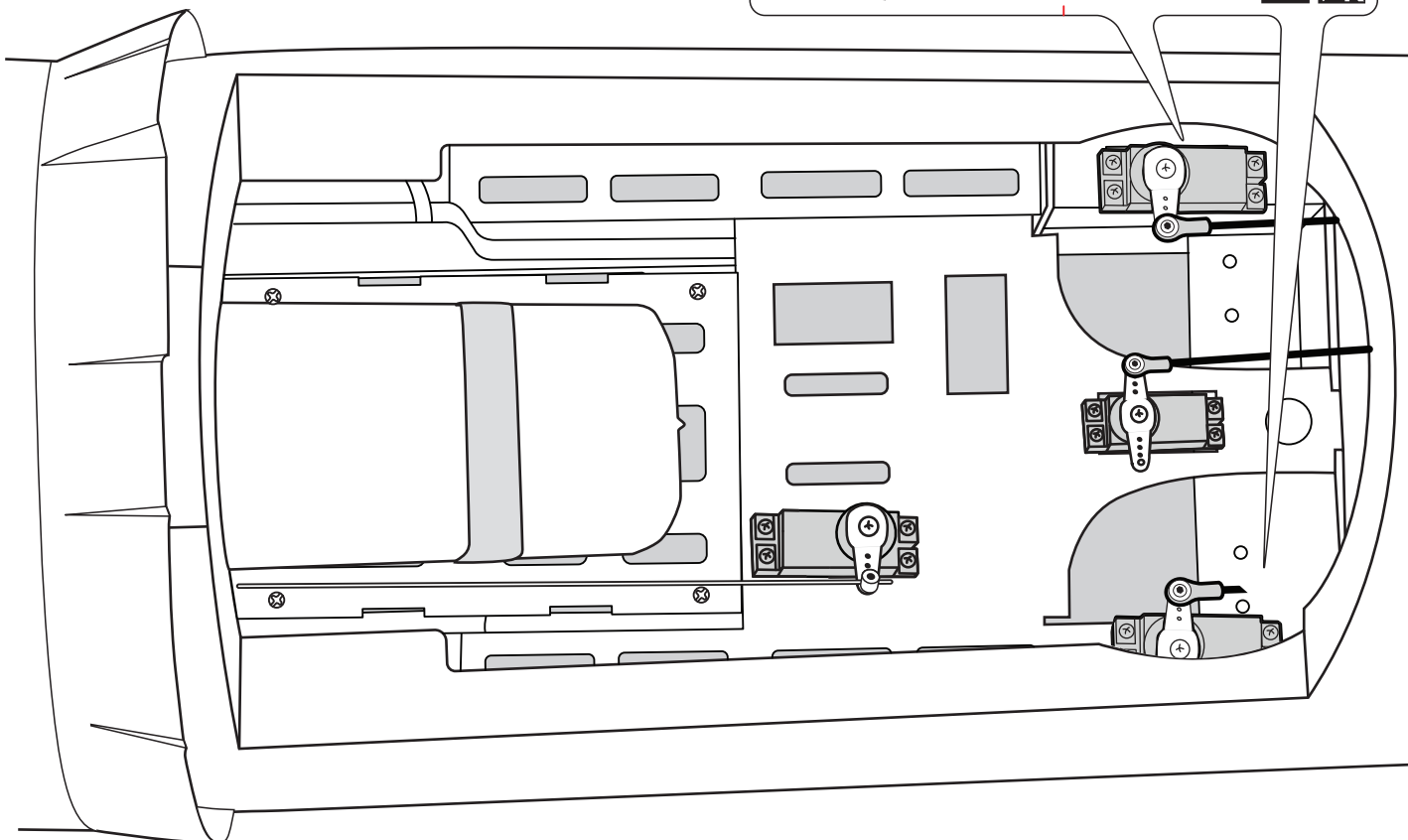

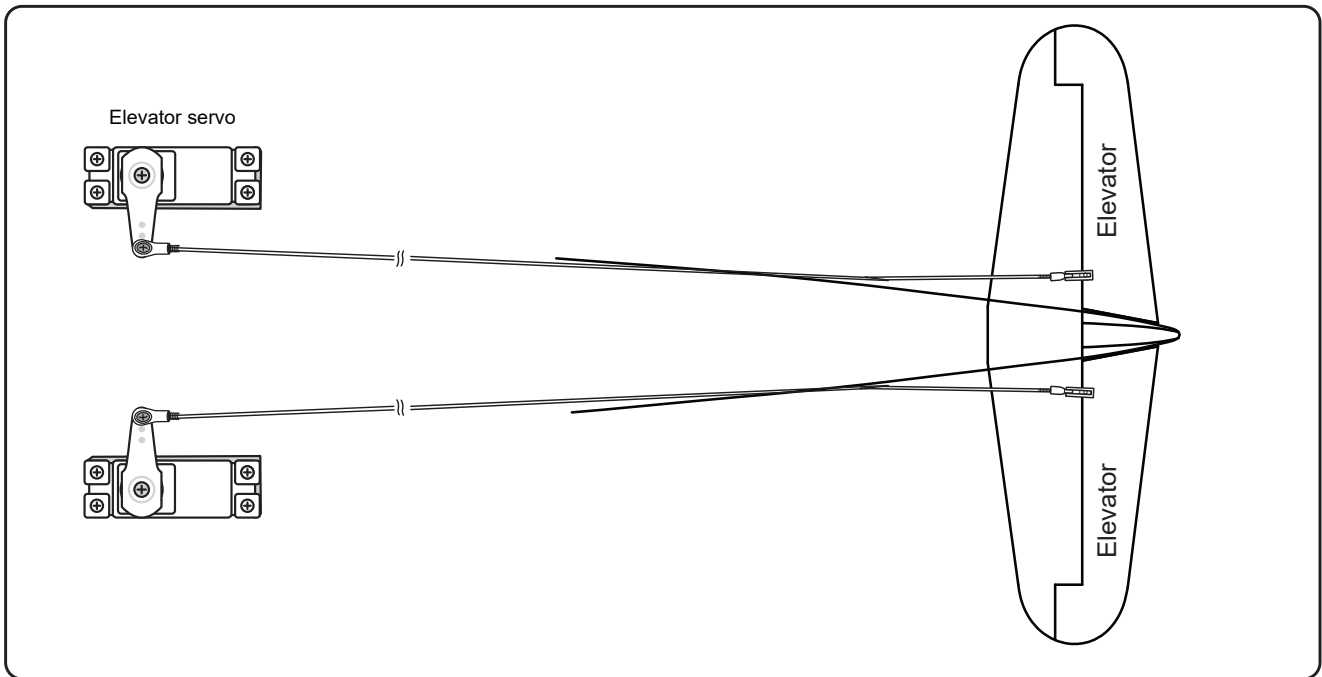

**INSTALLING THE TAIL GEAR, RUDDER**

- |   |   |
|---|---|
| 950mm Cable rod<br>----- 2              | 3x8mm Tp Screw<br>----- 1               |
| Connector<br>----- 2                    | 4x16mm Socket Head Cap Screw<br>----- 2 |
| M3 Metal Clevis<br>----- 2              | 4mm Flat Washer<br>----- 2              |
| Locknut<br>----- 4                      | 4mm Spring Washer<br>----- 2            |
| 3x12mm Tp screw<br>----- 4              | 2.6x30mm Push rod<br>----- 2            |
| Ball link --- 4                         | 3mm Flat Washer<br>----- 2              |
| 3x12mm Button Head Cap screw<br>----- 4 |   |

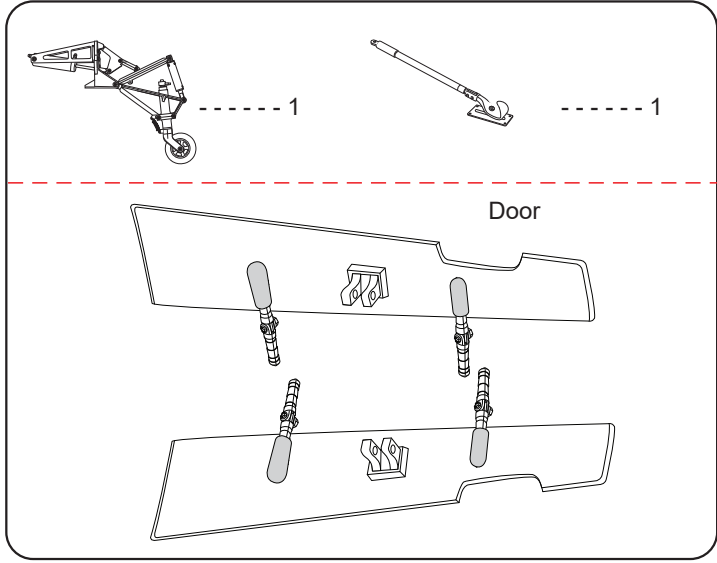



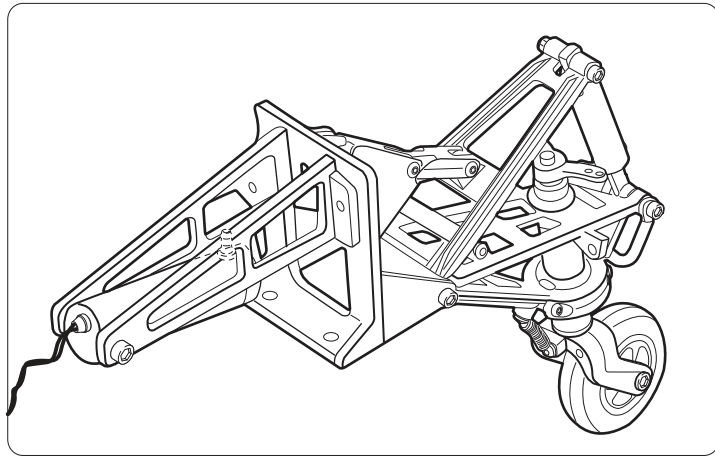

**BOTTOM VIEW**

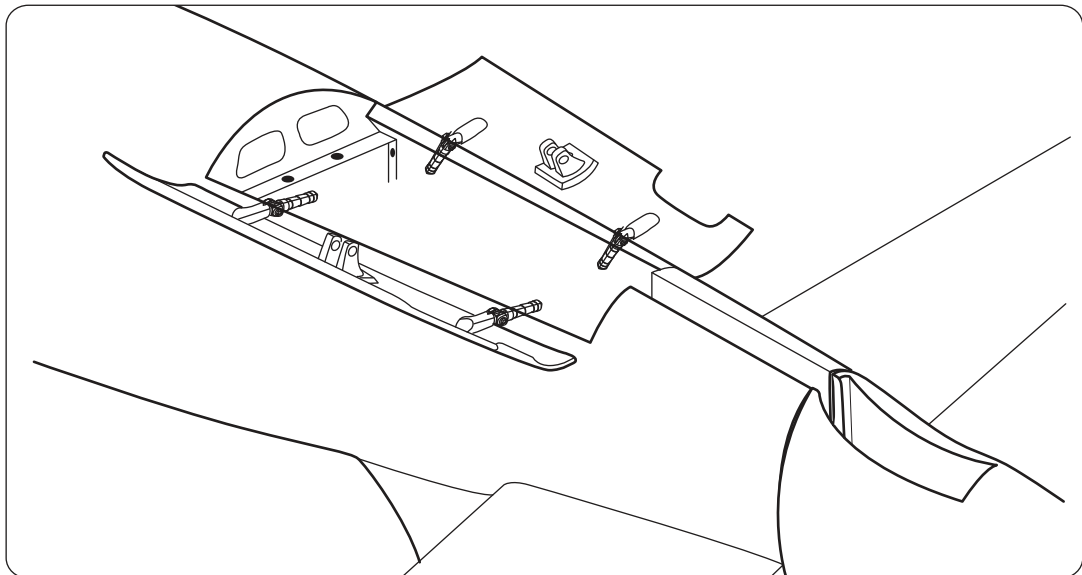
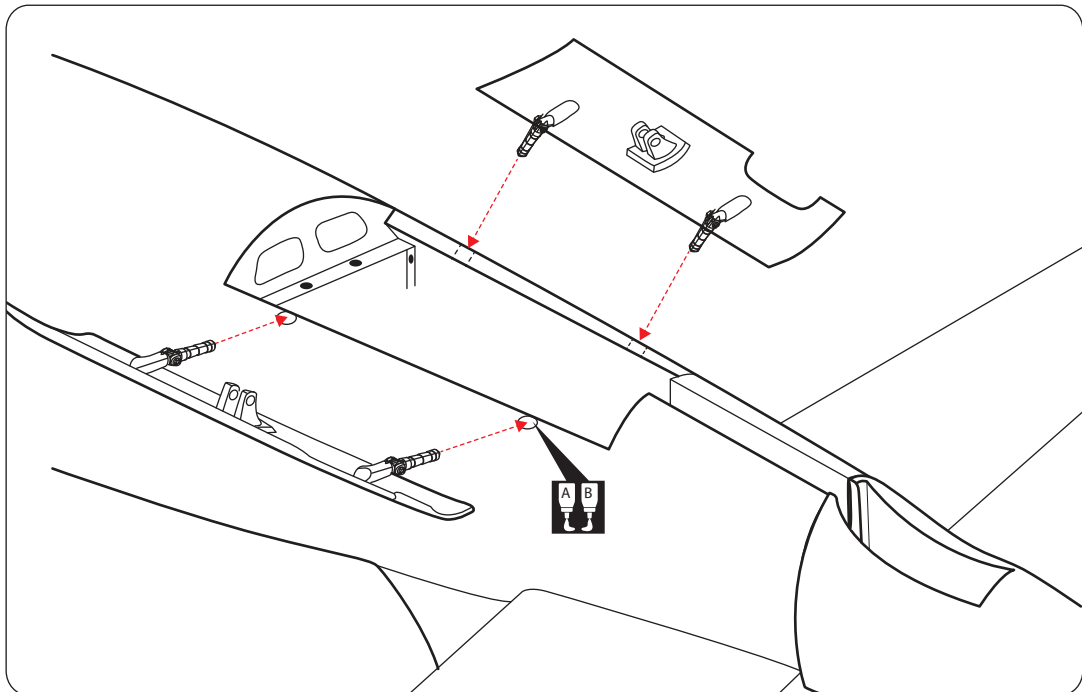

**BOTTOM VIEW**

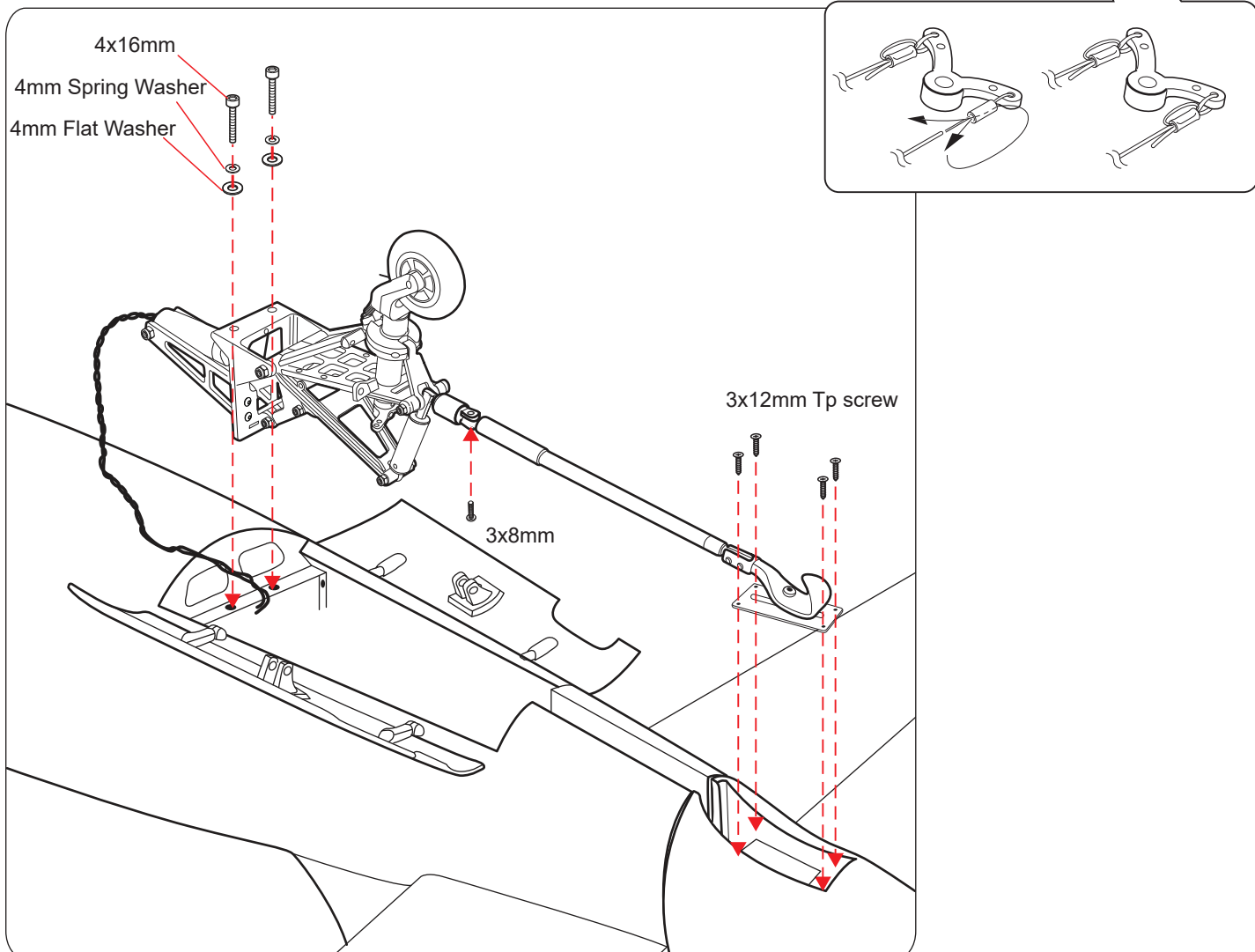
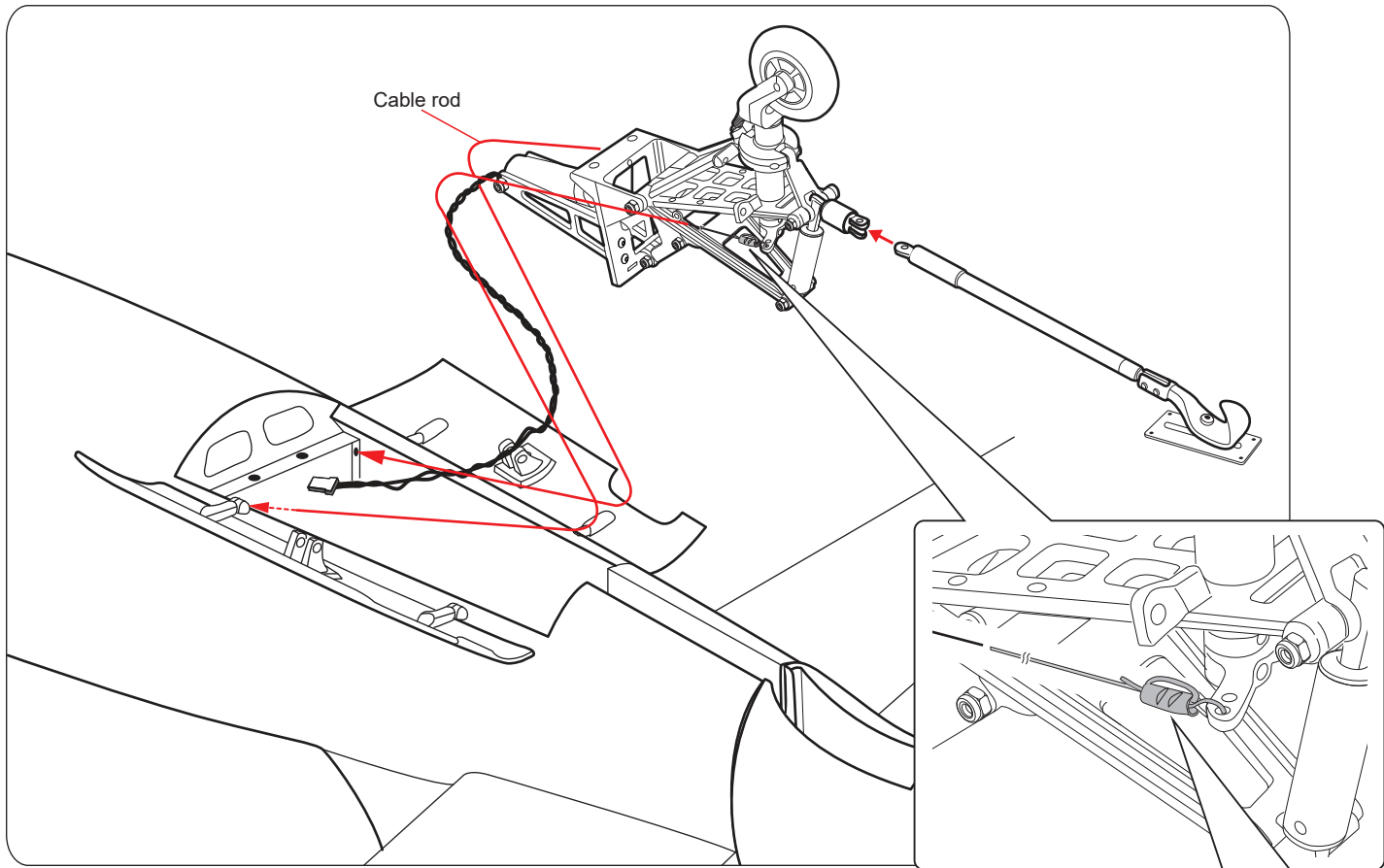

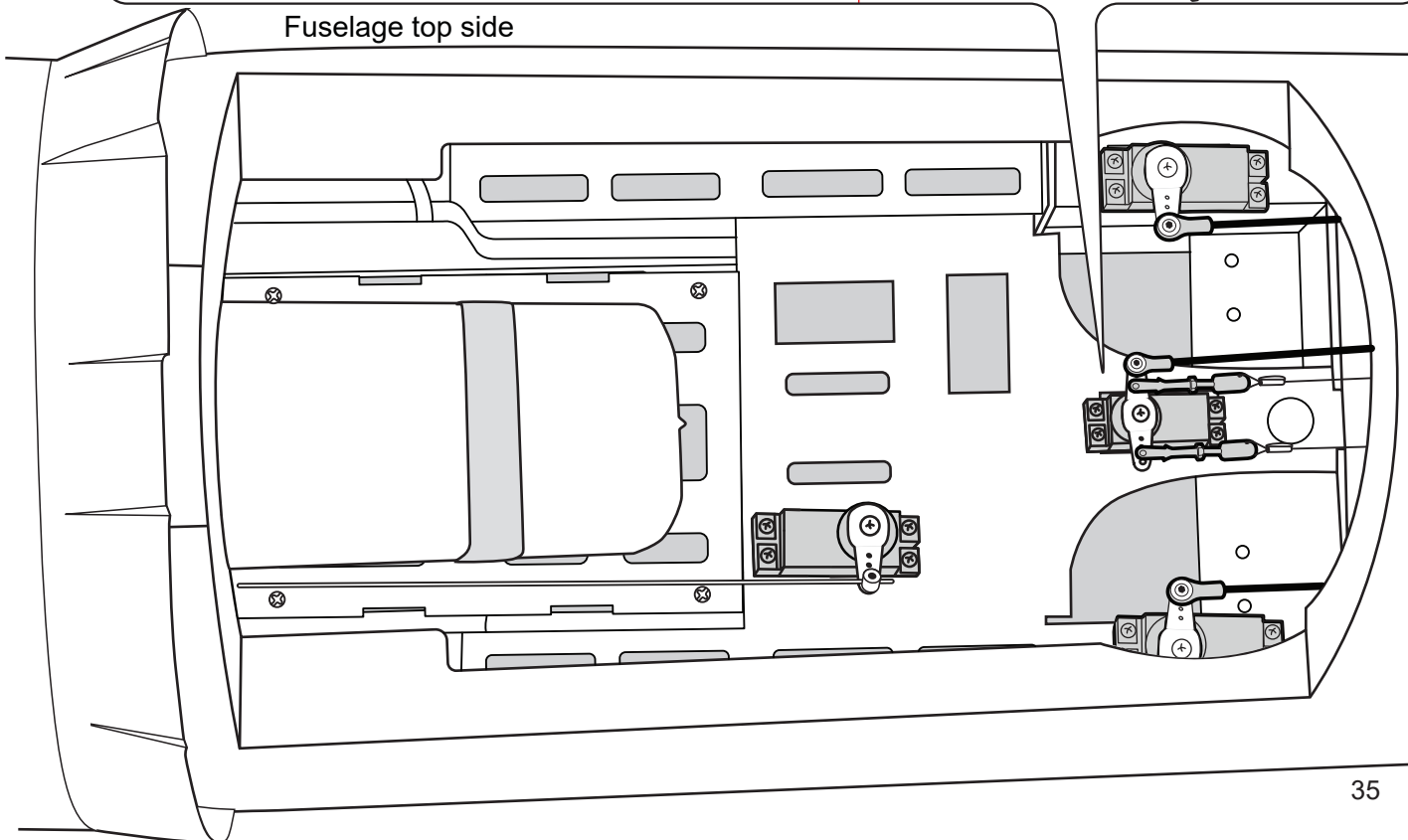
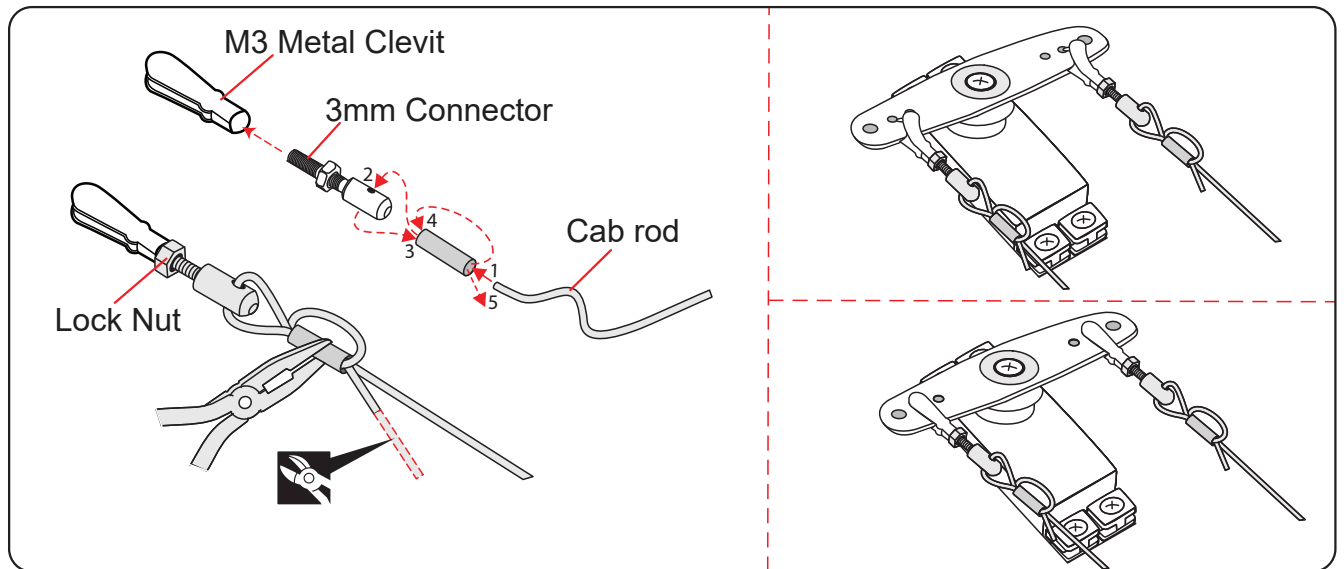
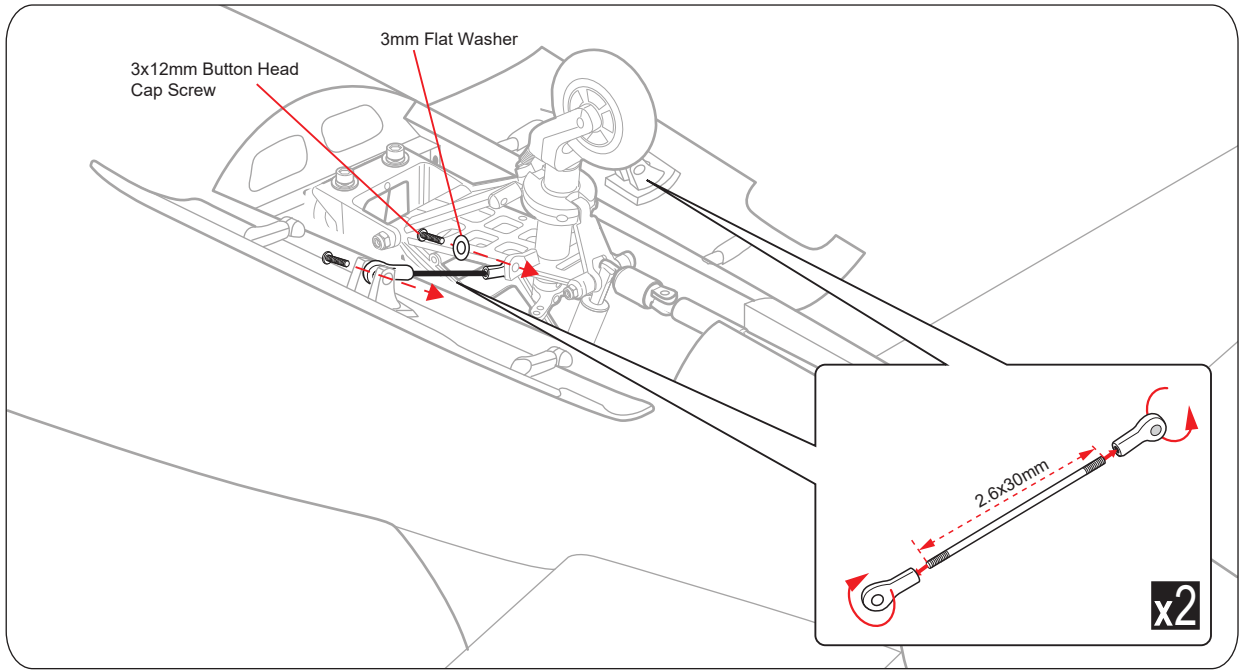

## INSTALLING THE SWITCH, RECEIVER AND BATTERY

1) Plug the servo leads and the switch lead into the receiver. You may want to plug an aileron extension into the receiver to make plugging in the aileron servo lead easier when you are installing the wing. Plug the battery pack lead into the switch.

2) Wrap the receiver and battery pack in the protective foam to protect them from vibration. Use a rubber band or masking tape to hold the foam in place.

 Do not permanently secure the receiver and battery until after balancing the model.

### INSTALLING THE SWITCH

1) The switch should be mounted on the fuselage side, opposite the muffler, close enough to the receiver so the lead will reach. Use the face plate of the switch cut out and locate the mounting holes.

2) Cut out the switch hole using a modeling knife. Use a 2mm drill bit and drill out the two mounting holes through the fuselage side.

3) Secure the switch in place using the two machine screws provided with the radio system.

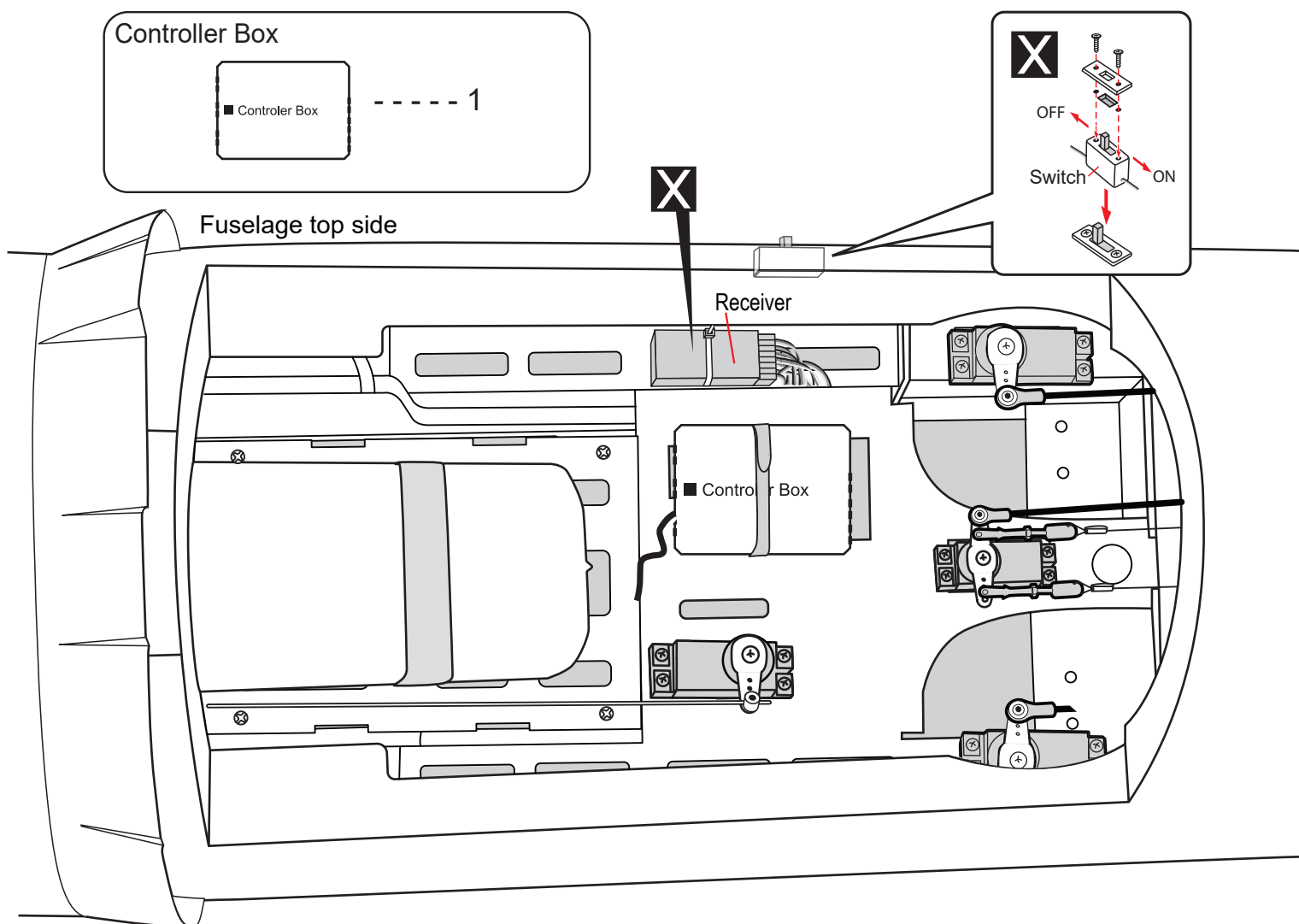

### INSTALLING COCKPIT FUSELAGE

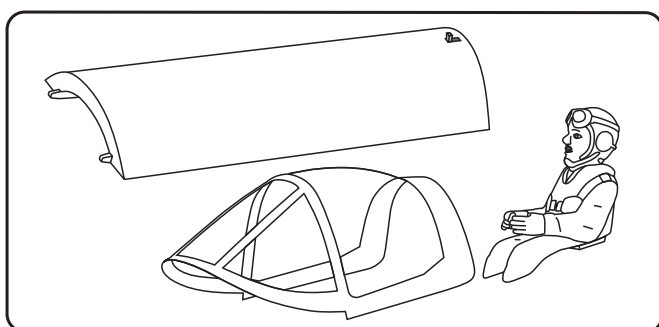

Position the canopy so the rear frame on the canopy is aligned with the rear edge of the cockpit opening. Use canopy glue to secure the canopy to the canopy hatch. Use low-tack tape to hold the canopy in position until the glue fully cures. Wrap the tape completely around the canopy hatch.

 Must be purchased separately!

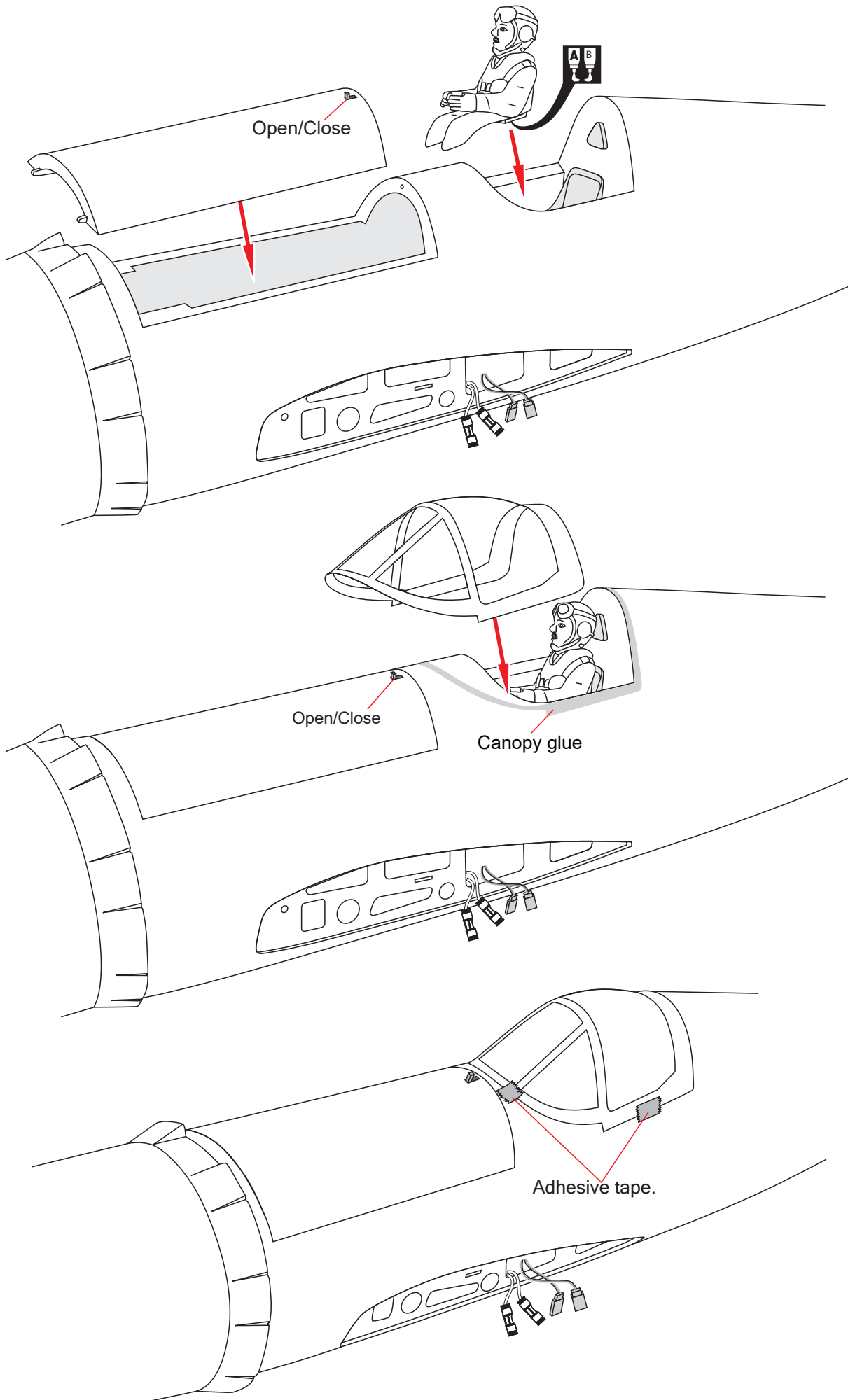

Apply epoxy glue.

# INSTALLING THE WING TO THE FUSELAGE

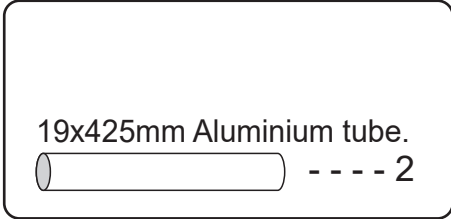

\*\*\* Test fit the aluminium tube dihedral brace into each wing haft. The brace should slide in easily. If not, use 220 grit sand around the edges and ends of the brace until it fits properly.

Fuselage top side  
Attach the aluminium tube  
into the fuselage.

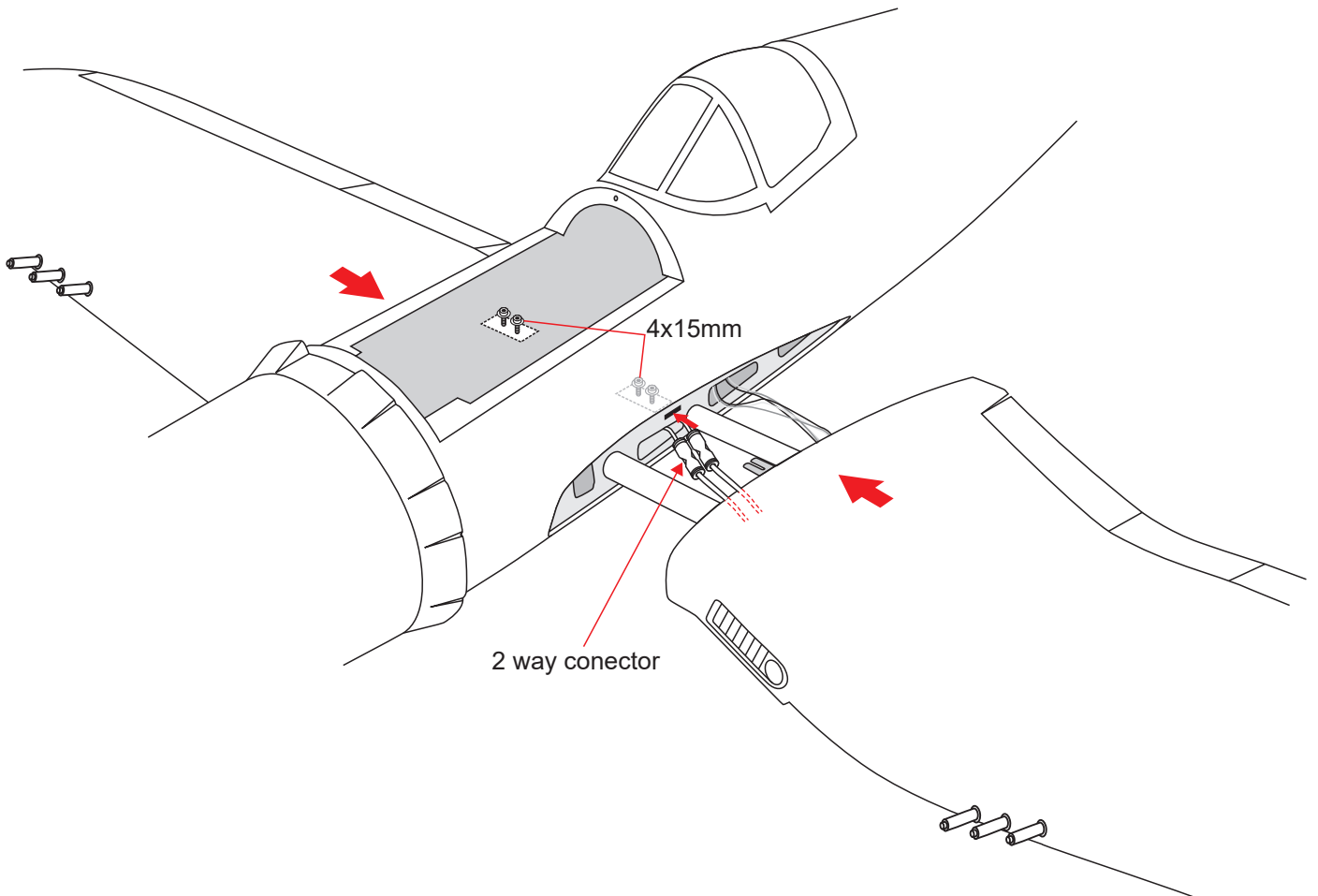
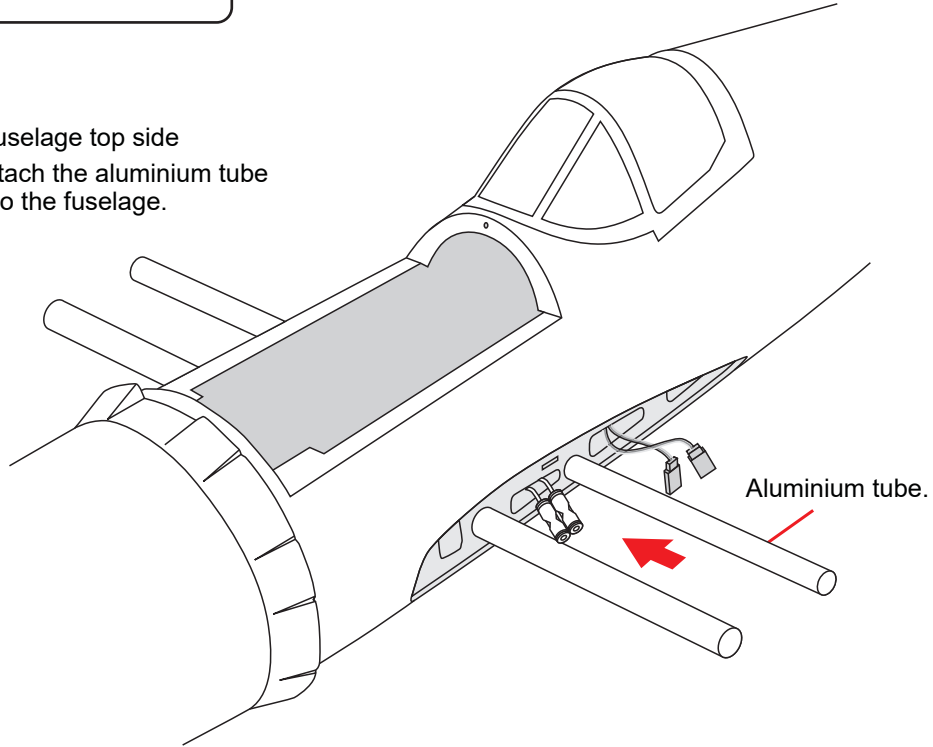

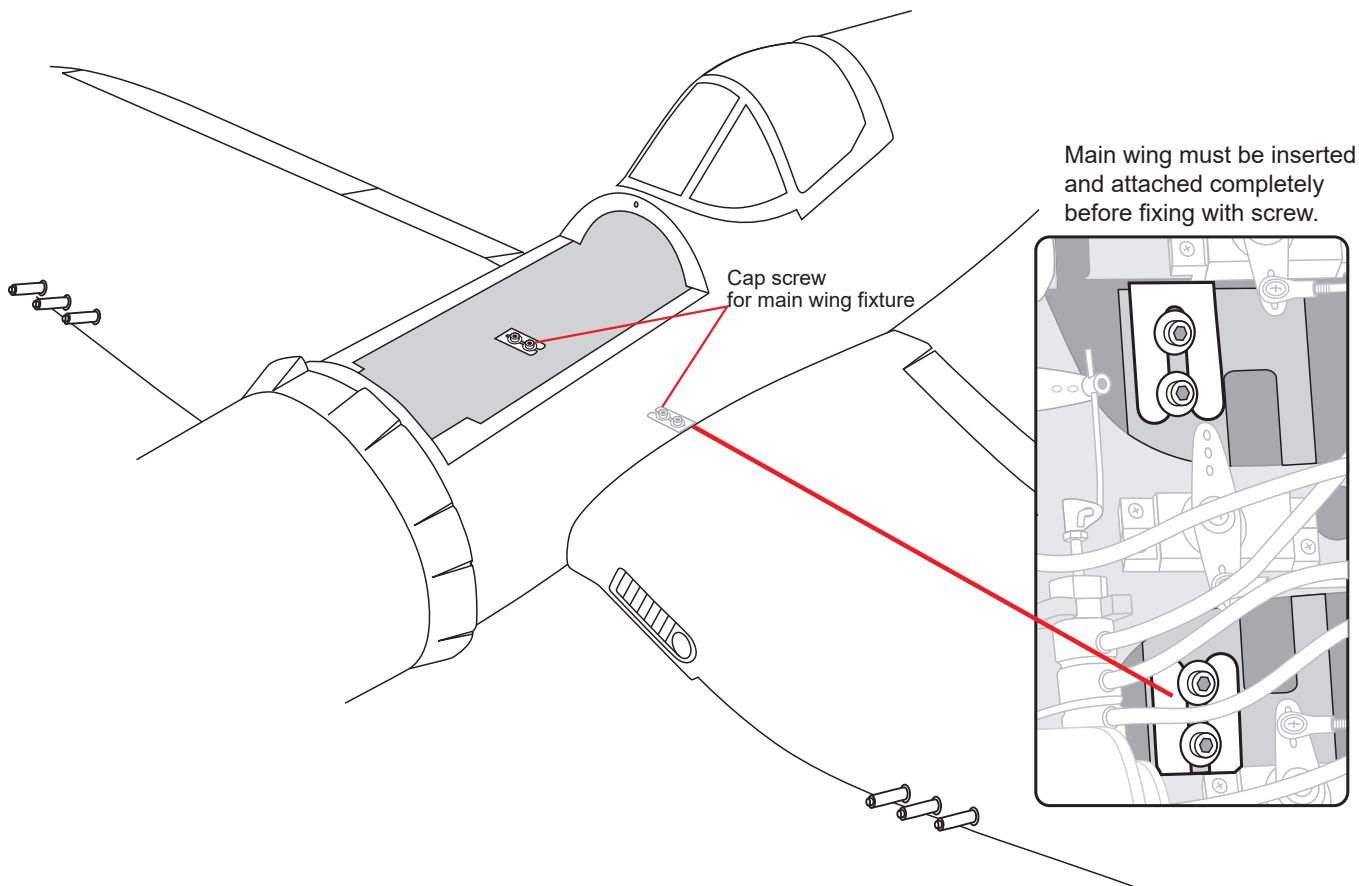

## INSTALLING THE PROPELLER

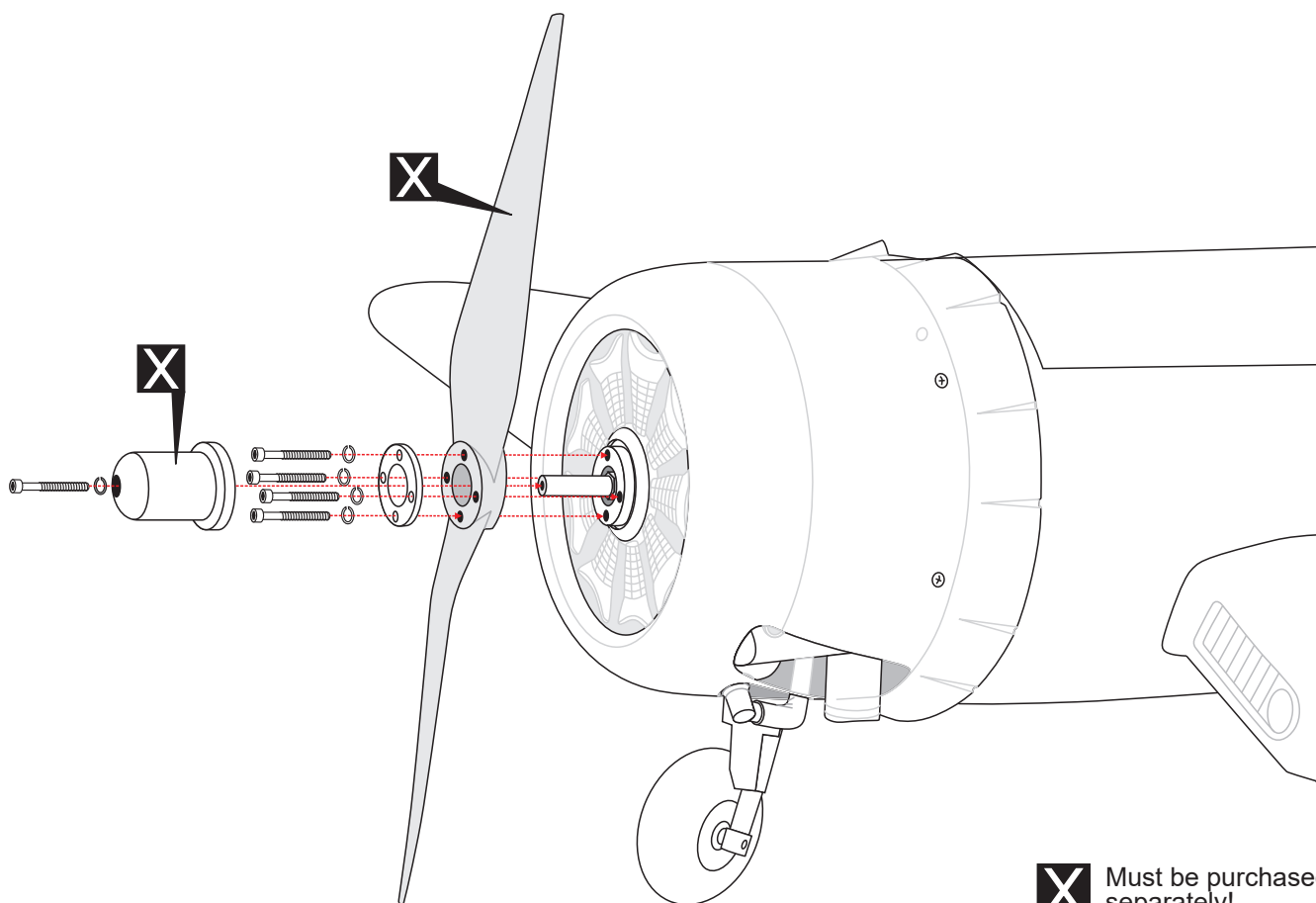

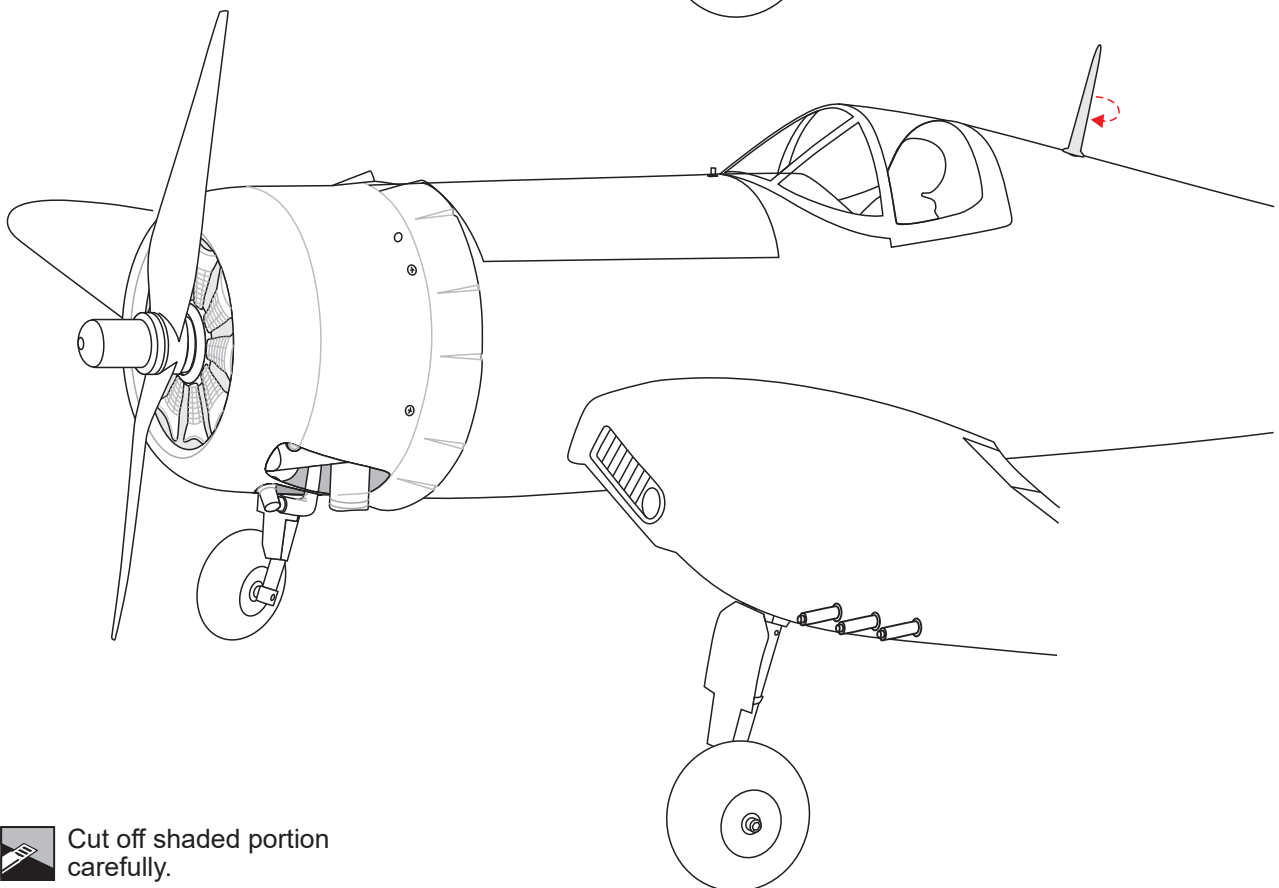
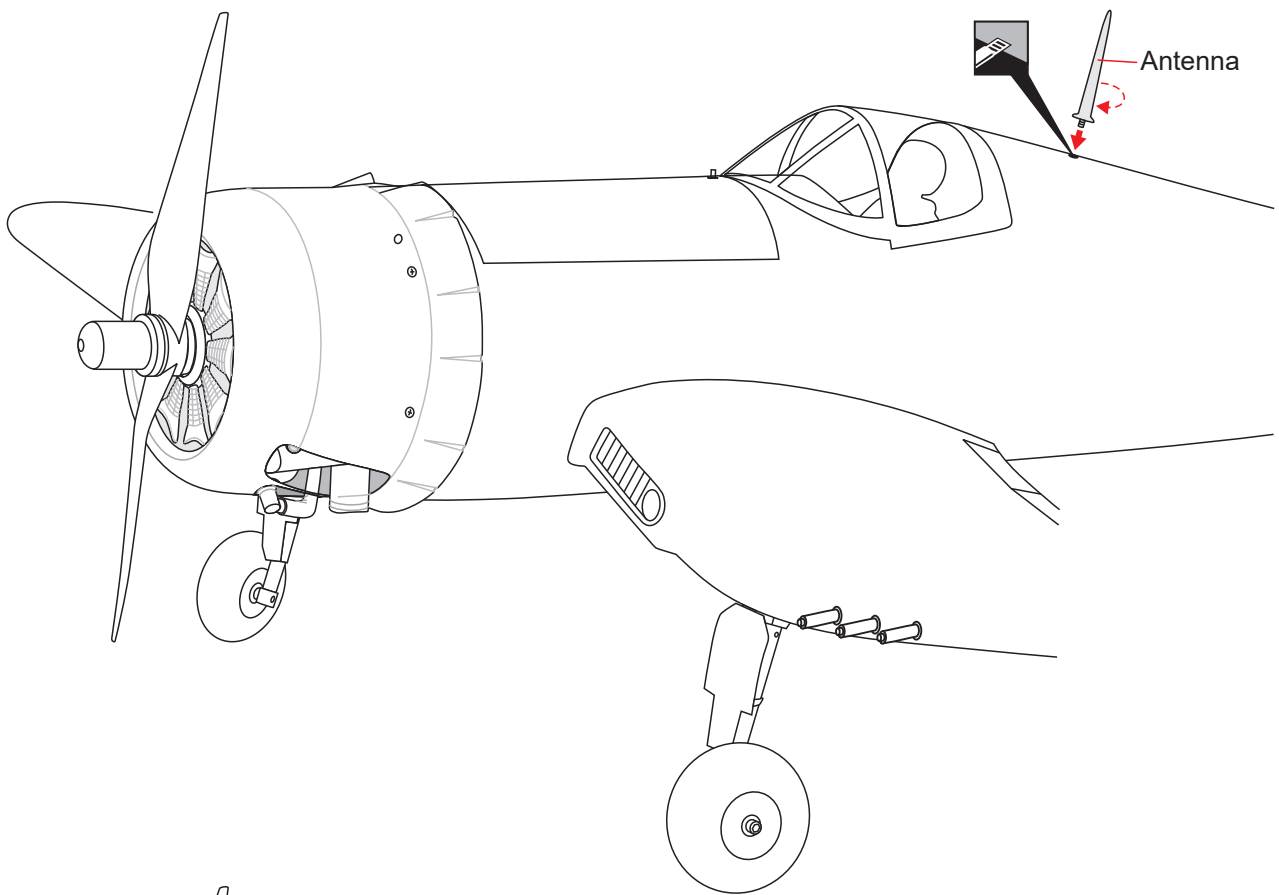
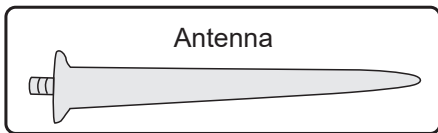

 Cut off shaded portion carefully.



**BALANCING**

1) It is critical that your airplane be balanced correctly. Improper balance will cause your plane to lose control and crash.

THE CENTER OF GRAVITY IS LOCATED 128MM BACK FROM THE LEADING EDGE OF THE WING. AT THE FUSELAGE. BALANCE A PLANE UPSIDE DOWN WITH THE FUEL TANK EMPTY.

2) Mount the wing to the fuselage. Using a couple of pieces of masking tape, place them on the top side of the wing 128mm back from the leading edge, at the fuselage sides.

3) Turn the airplane upside down. Place your fingers on the masking tape and carefully lift the plane.

4) If the nose of the plane falls, the plane is nose heavy. To correct this first move the battery pack further back in the fuselage. If this is not possible or does not correct it, stick small amounts of lead weight on the fuselage under the horizontal stabilizer. If the tail of the plane falls, the plane is tail heavy. To correct this, move the battery and receiver forward or if this is not possible, stick weight into the firewall. When balanced correctly, the airplane should sit level or slightly nose down when you lift it up with your fingers.

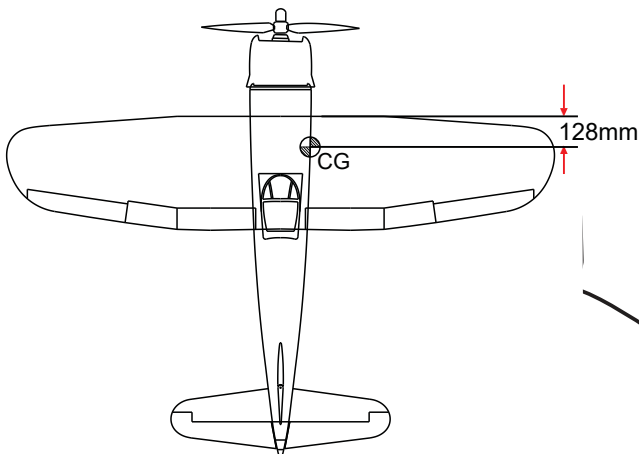

**LATERAL BALANCE**



After you have balanced a plane on the C.G. You should laterally balance it. Doing this will help the airplane track straighter.

1. Turn the airplane upside down. Attach one loop of heavy string to the engine crankshaft and one to the tail wheel wire. With the wings level, carefully lift the airplane by the string. This may require two people to make it easier.
2. If one side of the wing falls, that side is heavier than the opposite. Add small amounts of lead weight to the bottom side of the lighter wing half's wing tip. Follow this procedure until the wing stays level when you lift the airplane.

6 x 25mm Plastic Screw	-----	2
Plate of plywood	-----	2
Aluminium Ø12mm	-----	1
1600mm	-----	1

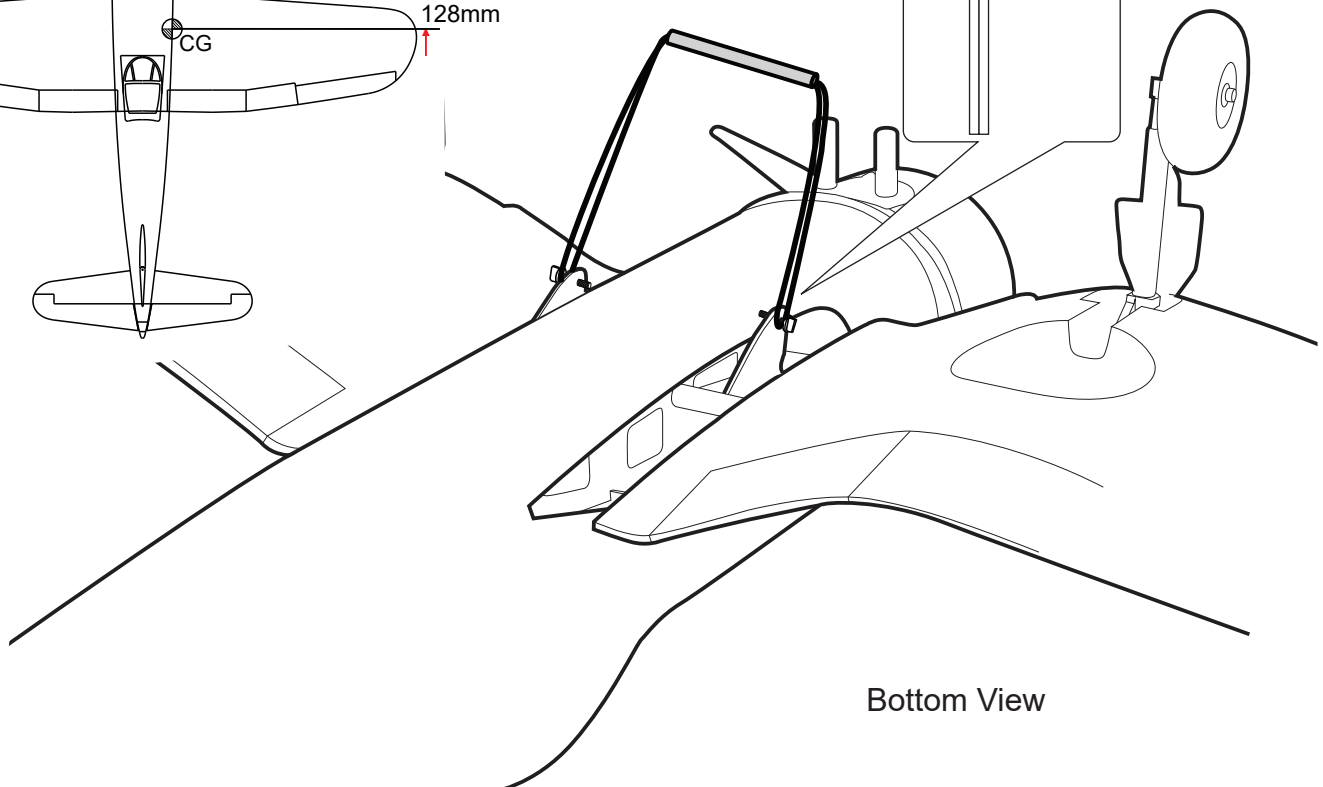
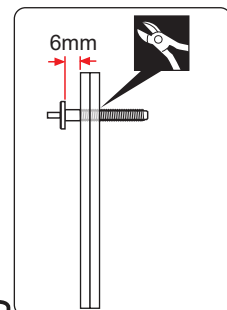

Bottom View

- ▶ In order to obtain the CG specified, reposition the receiver and other equipment.
- ▶ If not obtain the CG specified, add a weight and adjust.

Bottom View

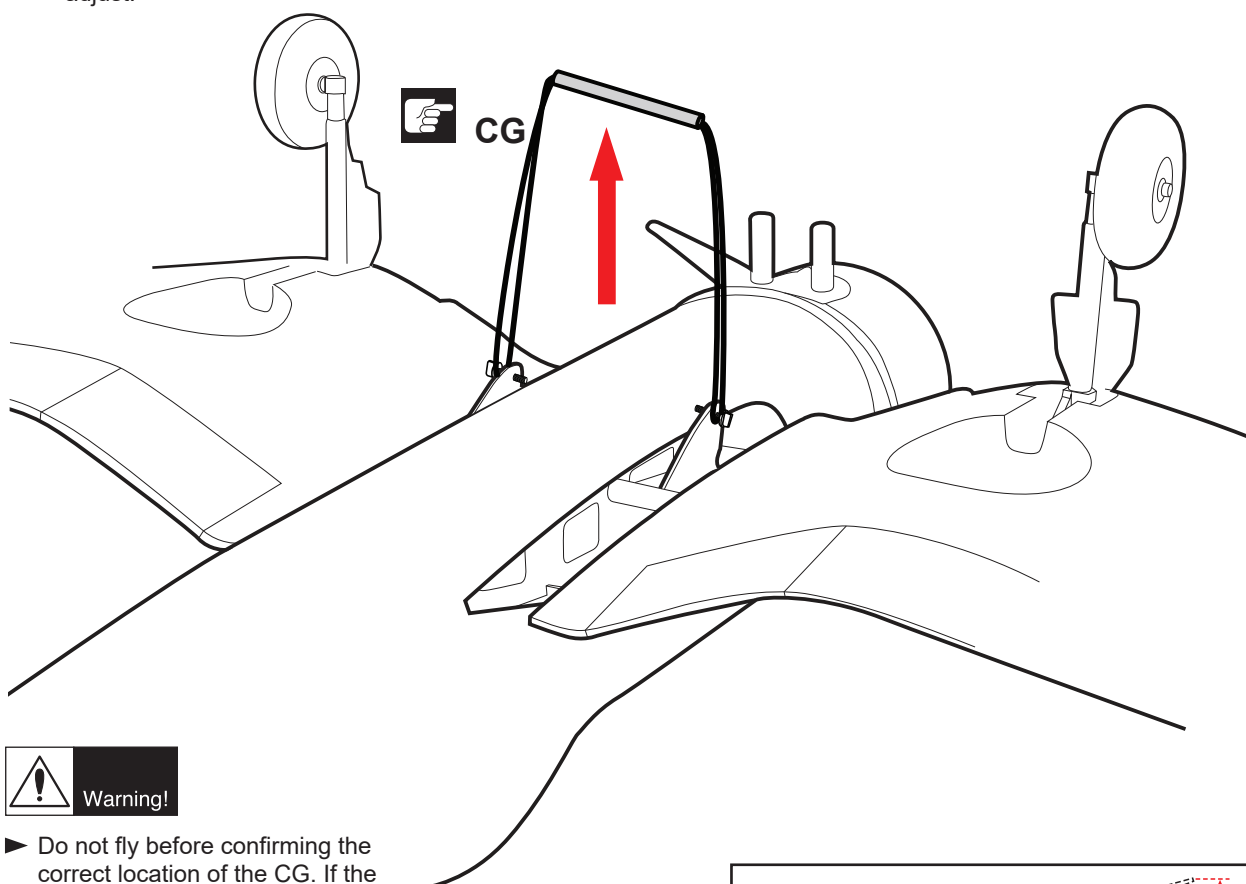

Warning!

- ▶ Do not fly before confirming the correct location of the CG. If the CG is incorrect, you lose control of your airplane which leads to accidents.

## CONTROL THROWS

- 1) We highly recommend setting up a plane using the control throws listed.
- 2) The control throws should be measured at the widest point of each control surface.
- 3) Check to be sure the control surfaces move in the correct directions.

Low rate:

- Aileron: 14 mm up 14 mm down
- Elevator: 12 mm up 12 mm down
- Rudder: 25mm right 25 mm left
- Flap: 28 mm down for take off  
70 mm down for landing

High rate:

- Aileron: 20mm up 20 mm down
- Elevator: 18 mm up 18 mm down
- Rudder: 45 mm right 45 mm left
- Flap:

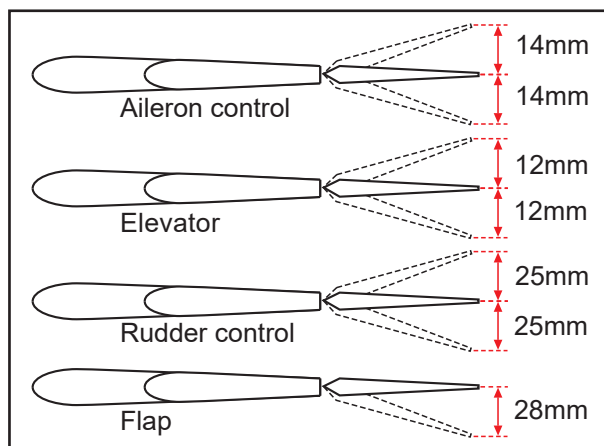

## PRE-FLIGHT CHECK

- 1) Completely charge your transmitter and receiver batteries before your first day of flying.
- 2) Check every bolt and every glue joint in your plane to ensure that everything is tight and well bonded.
- 3) Double check the balance of the airplane.
- 4) Check the control surface.
- 5) Check the receiver antenna. It should be fully extended and not coiled up inside the fuselage.
- 6) Properly balance the propeller.

# FOR YOUR RADIO INSTALLATION

## BASIC CONNECTION FOR AIRPLANE AND ADJUSTMENT OF SERVOS

Example of connection

- For more information, refer to radio system instruction manual.
- Follow instruction manual of Engine and Battery.

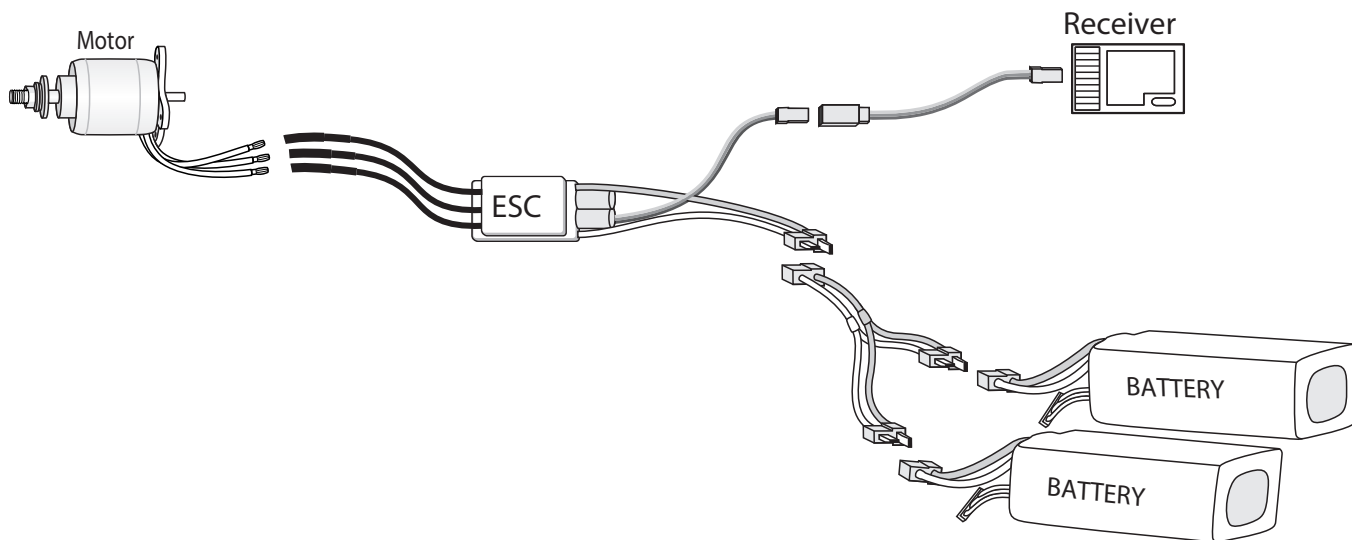
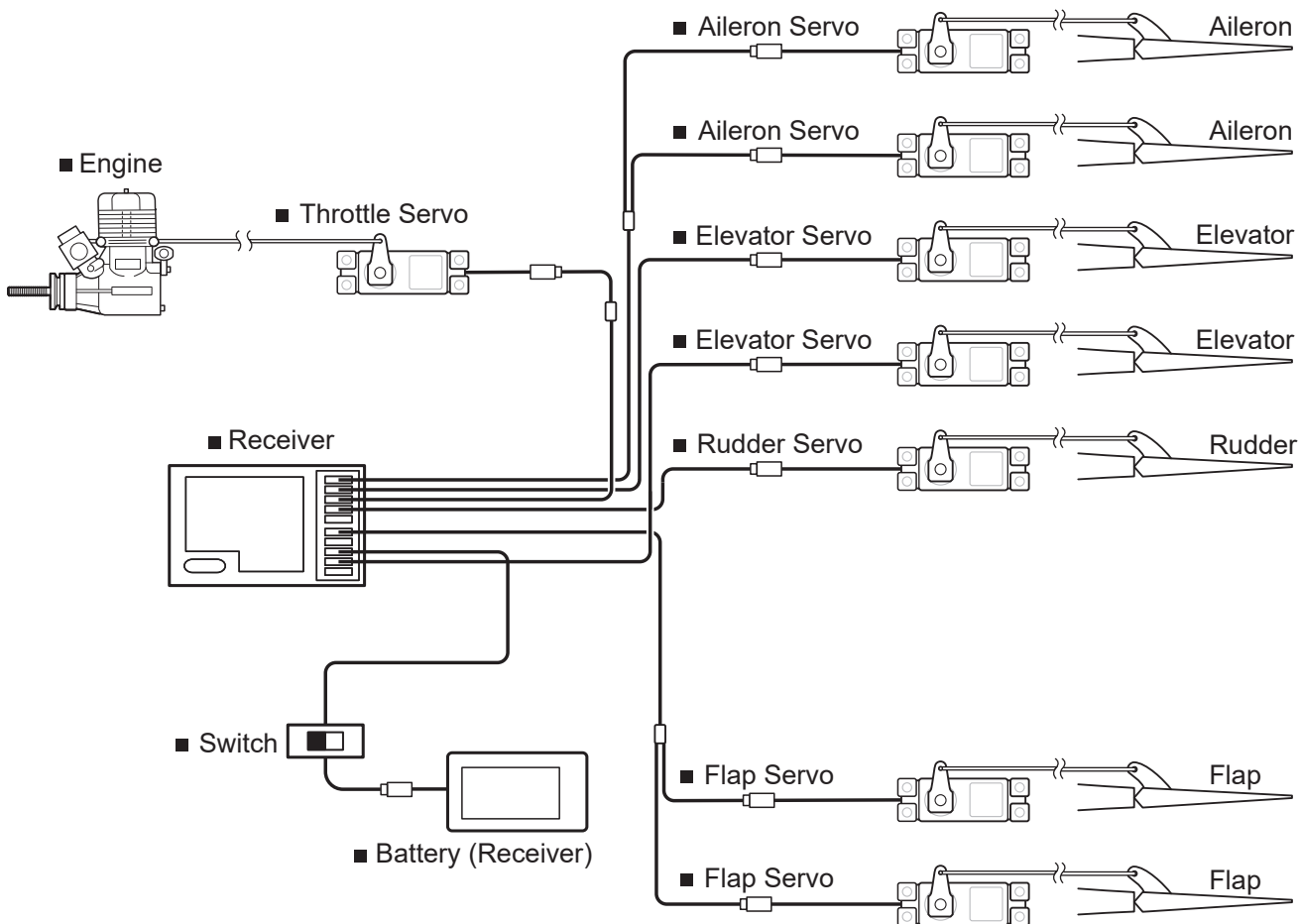

### MAIN GEAR DIMENSIONAL DETAIL

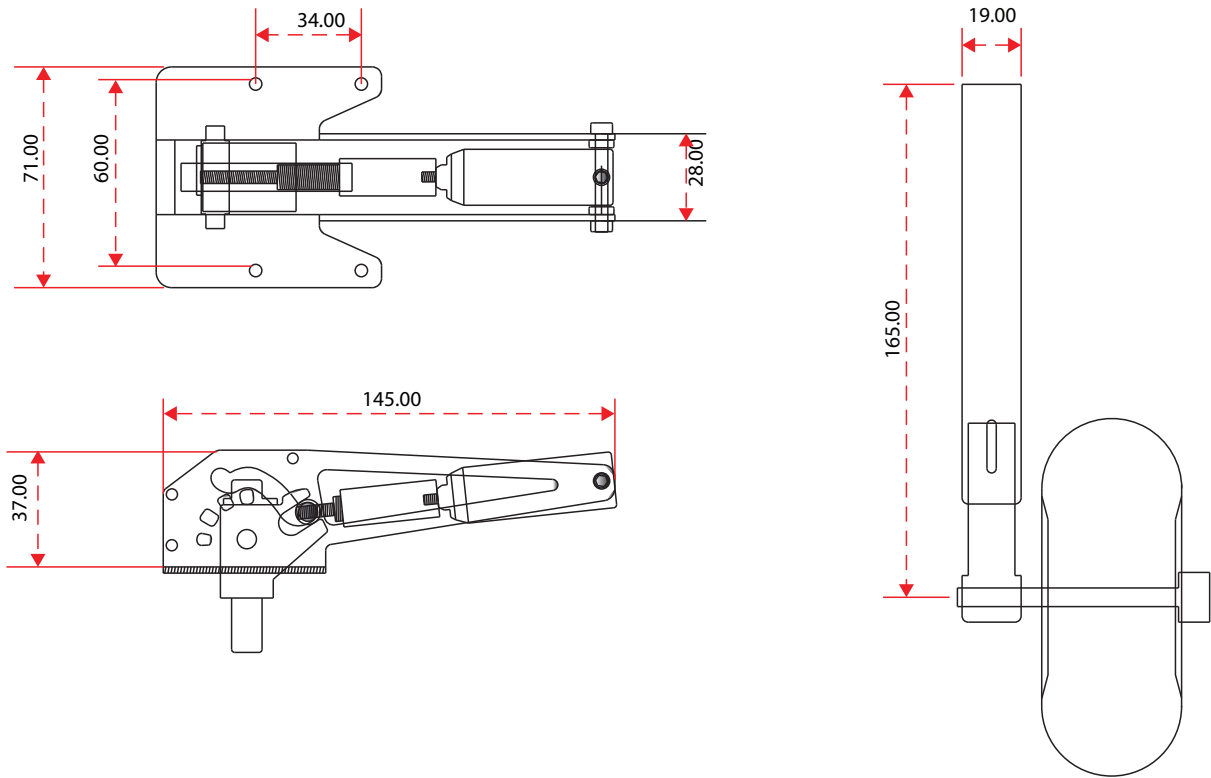

### TAIL GEAR DIMENSIONAL DETAIL

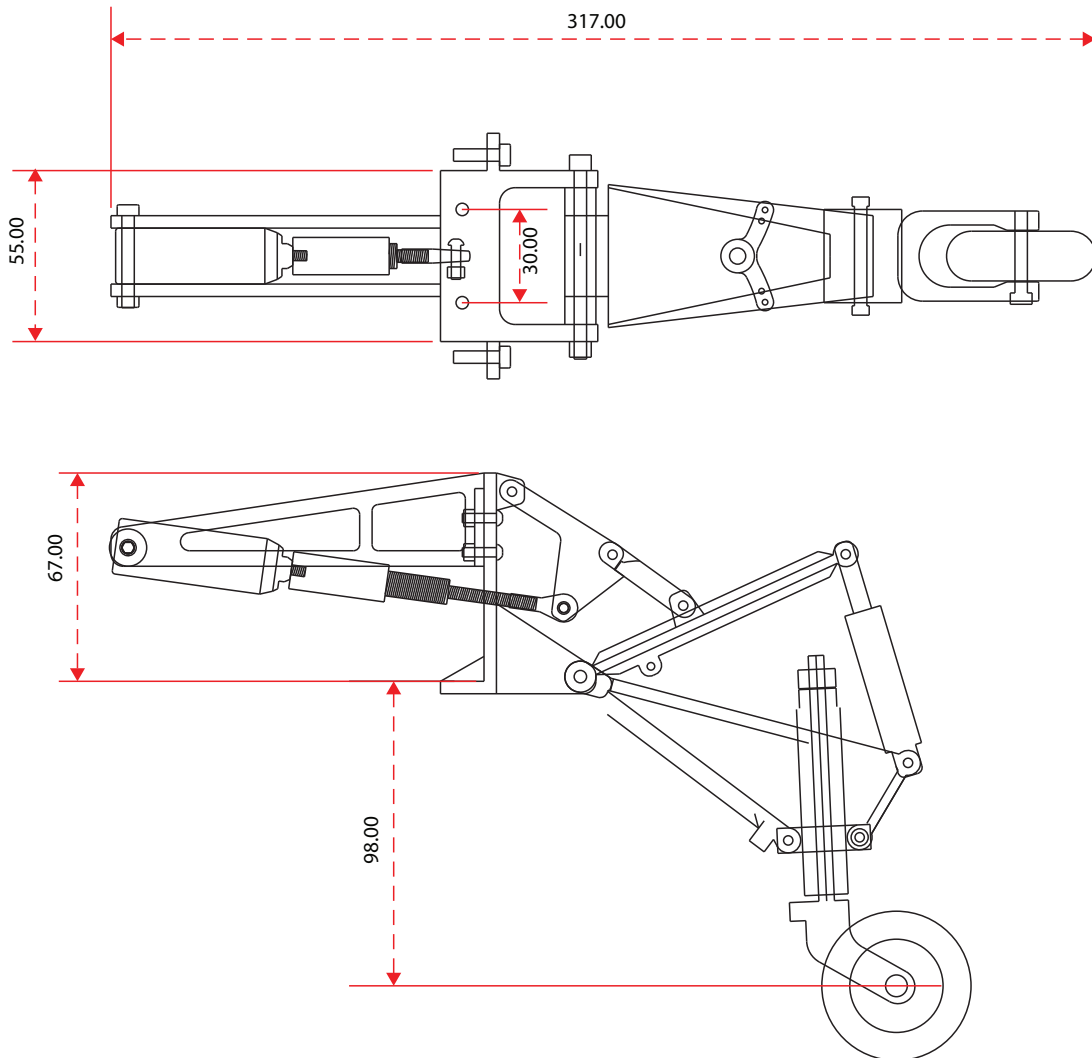

**EXPLODED VIEW**

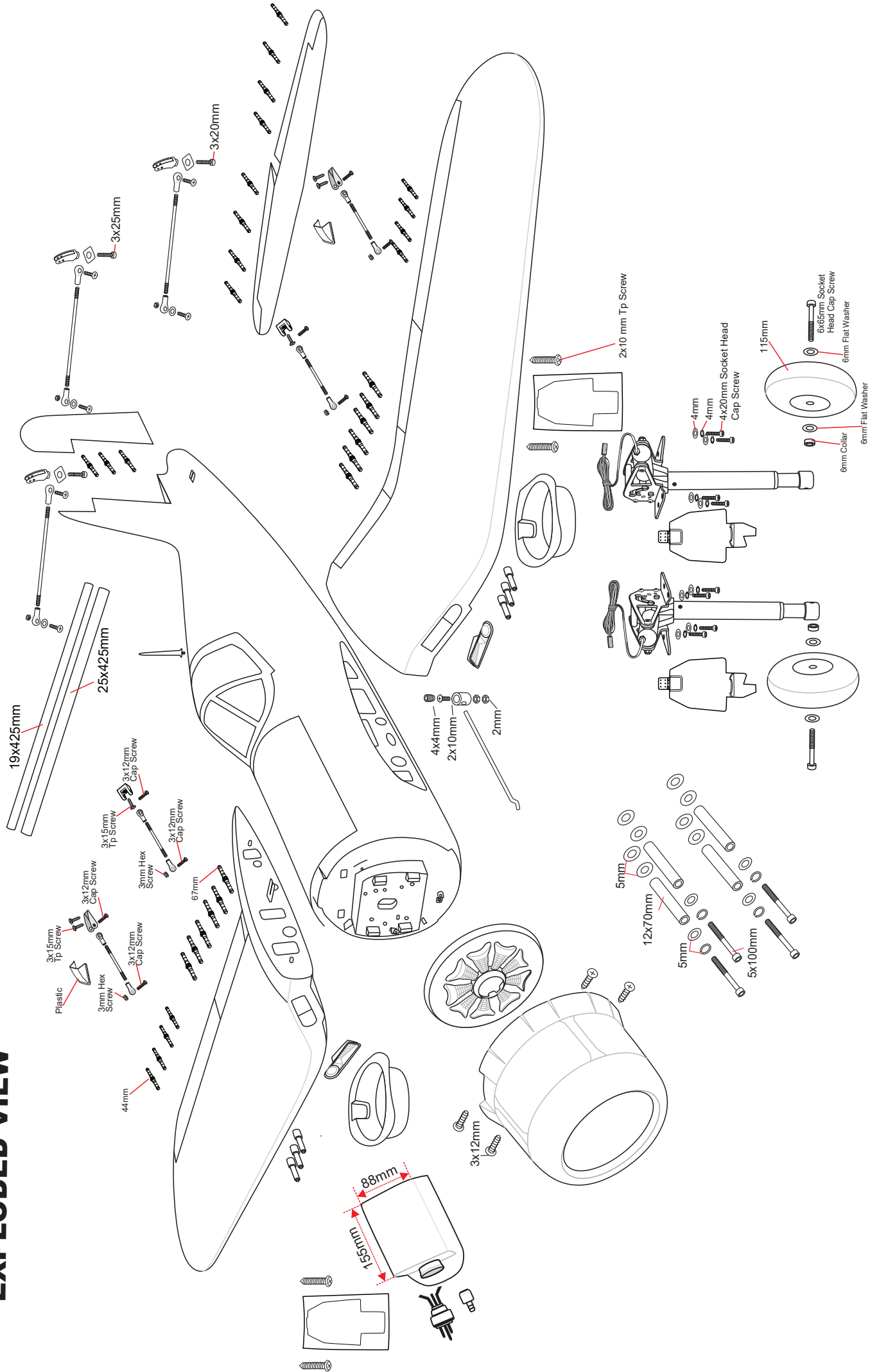

# I/C FLYING WARNINGS

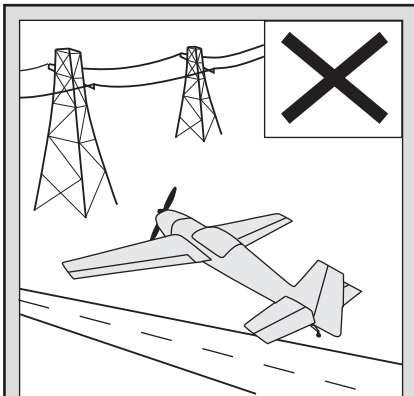

NEVER fly near power lines, aerials or other dangerous areas including airports, motorways etc.

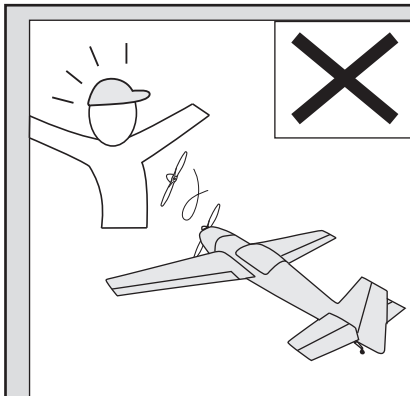

ALWAYS adjust the engine from behind the propeller, and do not allow any part of your body to be in line with the propeller.

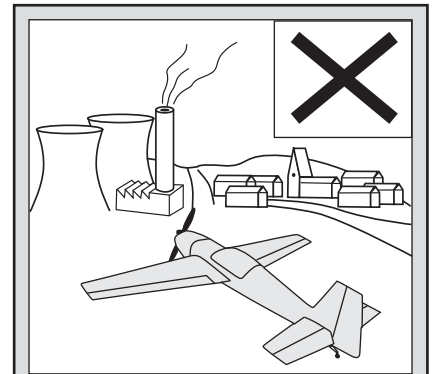

Always operate in open areas, away from factories, hospitals, schools, buildings and houses etc. NEVER fly your aircraft close to people or built up areas.

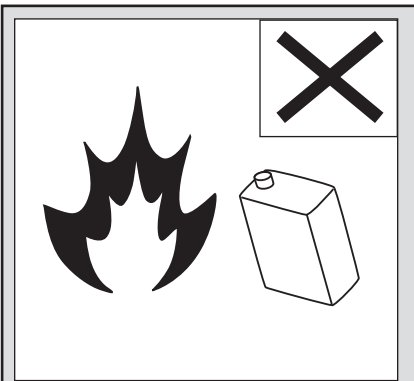

DO NOT dispose of empty fuel containers on a fire, this can lead to an explosion.

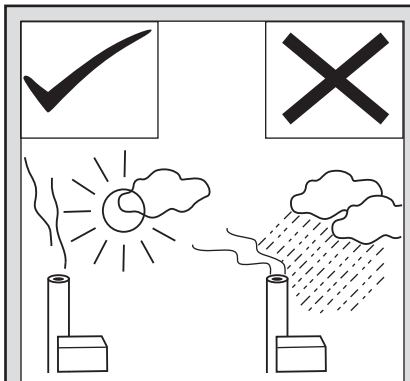

NEVER fly in wet conditions or on windy or stormy days.

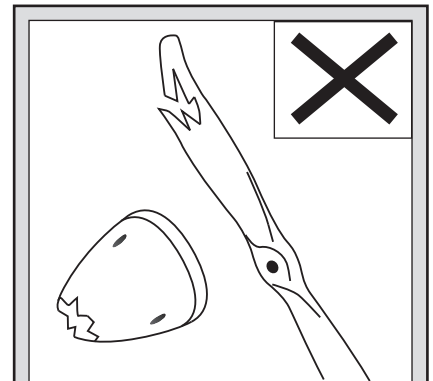

NEVER use damaged or deformed propellers or spinners.

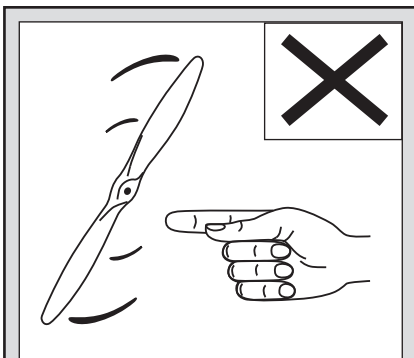

THE PROPELLER IS DANGEROUS. Keep fingers, clothing (ties, shirt sleeves, scarves) or any other loose objects that could be caught or drawn in, away from the propeller. Take care at ALL times.

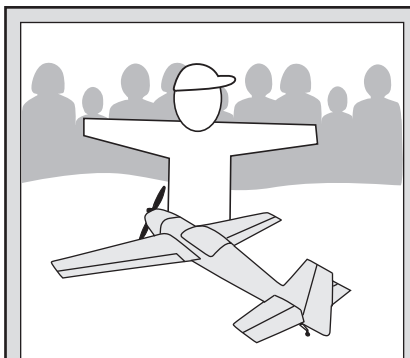

Keep all onlookers (especially small children and animals) well back from the area of operation. This is a flying aircraft, which will cause serious injury in case of impact with a person or animal.

# I/C FLYING GUIDELINES

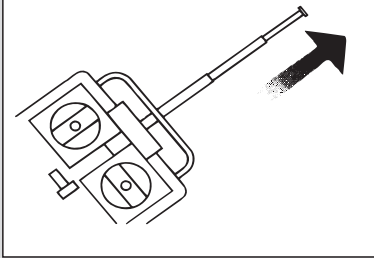

When ready to fly, first extend the transmitter aerial.

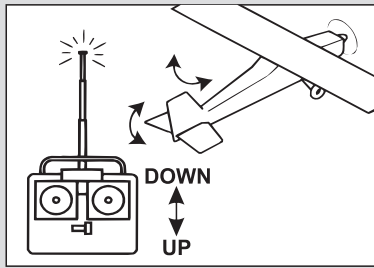

Operate the control sticks on the transmitter and check that the control surfaces move freely and in the CORRECT directions.

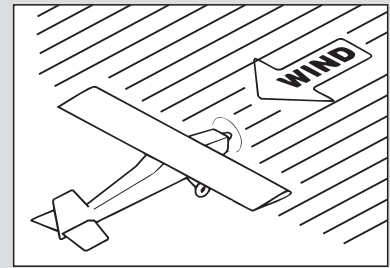

ALWAYS land the model INTO the wind, this ensures that the model lands at the slowest possible speed.

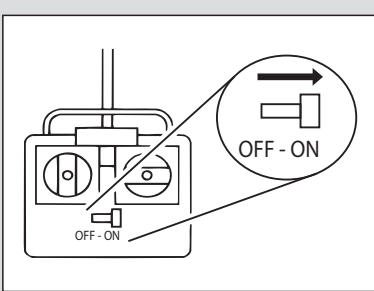

Switch on the transmitter.

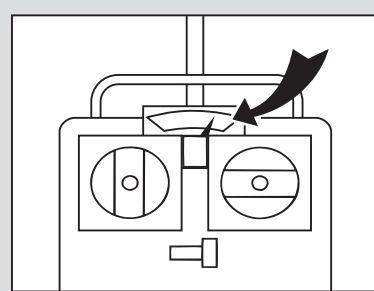

Check that the transmitter batteries have adequate power.

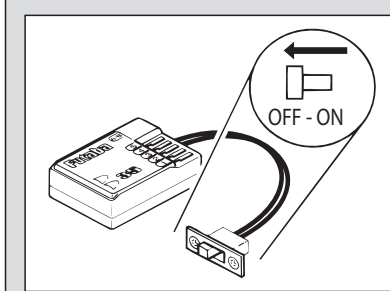

Switch off the receiver.

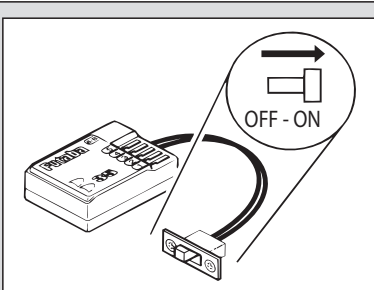

Switch on the receiver.

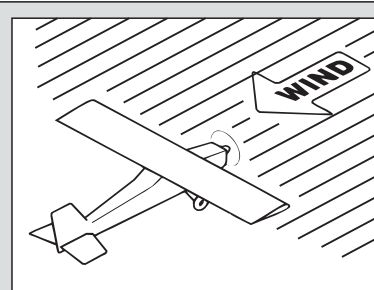

ALWAYS take off into the wind.

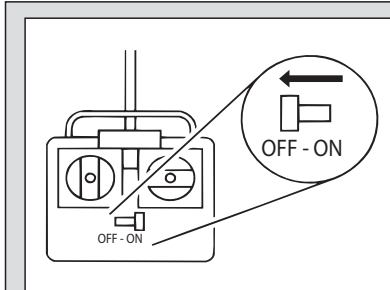

Switch off the transmitter.

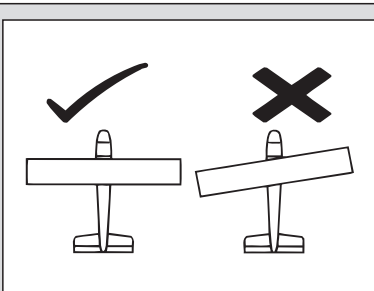

Check that the wings are correctly fitted to the fuselage.

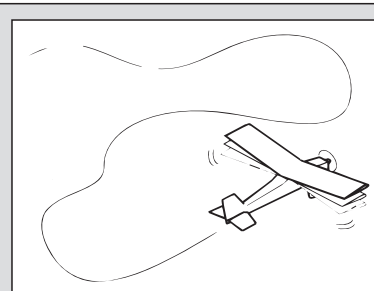

If the model does not respond correctly to the controls, land it as soon as possible and correct the fault.

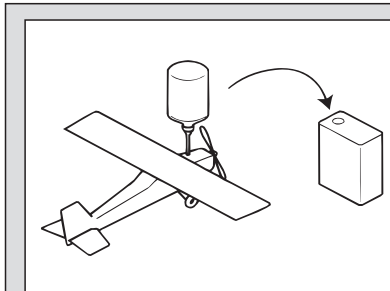

Empty the fuel tank after flying, fuel left in the tank can cause corrosion and lead to engine problems.