

Factor 3D



INSTRUCTION MANUAL

SPECIFICATIONS

Wingspan: 38 in [965mm]	Radio: Four channel (minimum)	Motor: RimFire .10 (35-30-1250)
Length: 41.5 in [1055mm]	Five channel computer radio	
Weight: 28–32 oz [795–905 g]	with mixing capabilities	
Wing Area: 375 in ² [24.2 dm ²]	(for separate ailerons)	
Wing Loading: 10.8–12.3 oz/ft ² [33–38 g/dm ²]		

WARRANTY

Great Planes® Model Manufacturing Co. guarantees this kit to be free from defects in both material and workmanship at the date of purchase. This warranty does not cover any component parts damaged by use or modification. **In no case shall Great Planes' liability exceed the original cost of the purchased kit.** Further, Great Planes reserves the right to change or modify this warranty without notice.

In that Great Planes has no control over the final assembly or material used for final assembly, no liability shall be assumed nor accepted for any damage resulting from the use by the user of the final user-assembled product. By the act of using the user-assembled product, the user accepts all resulting liability.

If the buyer is not prepared to accept the liability associated with the use of this product, the buyer is advised to return

this kit immediately in new and unused condition to the place of purchase.

To make a warranty claim send the defective part or item to Hobby Services at the address below:

Hobby Services

3002 N. Apollo Dr. Suite 1
Champaign IL 61822 USA

Include a letter stating your name, return shipping address, as much contact information as possible (daytime telephone number, fax number, e-mail address), a detailed description of the problem and a photocopy of the purchase receipt. Upon receipt of the package the problem will be evaluated as quickly as possible.

READ THROUGH THIS MANUAL BEFORE STARTING CONSTRUCTION. IT CONTAINS IMPORTANT INSTRUCTIONS AND WARNINGS CONCERNING THE ASSEMBLY AND USE OF THIS MODEL.



Champaign, Illinois
(217) 398-8970, Ext 5
airsupport@greatplanes.com

TABLE OF CONTENTS

INTRODUCTION	2	Install the Elevator & Rudder Servos	7
Academy of Model Aeronautics	2	Install the Stab and Elevator	8
SAFETY PRECAUTIONS	2	Install the Motor, Speed Control and Receiver	11
DECISIONS YOU MUST MAKE	3	Install the Cowl	12
Radio Equipment	3	Install the Wheel and Wheel Pants	13
Transmitter	3	Apply the Decals	14
Receiver	3	GET THE MODEL READY TO FLY	14
Servos	3	Check the Control Directions	14
Connectors	3	Set the Control Throws	14
Motor Recommendations	3	Finish the Model	15
ESC (Electronic Speed Control)	3	Balance the Model (C.G.)	15
Propeller	3	Balance the Model Laterally	16
Flight Battery	3	PREFLIGHT	16
ADDITIONAL ITEMS REQUIRED	4	Identify Your Model	16
Required Adhesives & Building Supplies	4	Charge the Batteries	16
Optional Supplies and Tools	4	Range Check	16
IMPORTANT BUILDING NOTES	4	MOTOR SAFETY PRECAUTIONS	16
KIT INSPECTION	4	AMA SAFETY CODE EXCERPTS	16
ORDERING REPLACEMENT PARTS	4	General	16
KIT CONTENTS	5	Radio Control	17
PREPARATIONS	6	CHECK LIST	17
ASSEMBLE THE WINGS	6	FLYING	17
Install the Ailerons	6	Takeoff	18
ASSEMBLE THE FUSELAGE	7	Flight	18
Install the Main Landing Gear	7	Landing	18

INTRODUCTION

The Factor 3D EP ARF was designed from the ground up to provide one of the best flying 3D airplanes available today. Whether you are just learning to fly 3D or are already an expert, you will love this airplane.

For the latest technical updates or manual corrections to the Factor 3D EP ARF visit the Great Planes web site at www.greatplanes.com. Open the "Airplanes" link, and then select the Factor 3D EP ARF. If there is new technical information or changes to this model a "tech notice" box will appear in the upper left corner of the page.

Academy of Model Aeronautics

We urge you to join the AMA (Academy of Model Aeronautics) and a local R/C club. The AMA is the governing body of model aviation and membership is required to fly at AMA clubs. Though joining the AMA provides many benefits, one of the primary reasons to join is liability protection. Coverage is not limited to flying at contests or on the club field. It even applies to flying at public demonstrations and air shows. Failure to comply with the Safety Code (excerpts printed in the back of the manual) may endanger insurance coverage. Additionally, training programs and instructors are available at AMA club

sites to help you get started the right way. There are over 2,500 AMA chartered clubs across the country. Contact the AMA at the address or toll-free phone number below:

Academy of Model Aeronautics

5151 East Memorial Drive
Muncie, IN 47302-9252

Tele. (800) 435-9262

Fax (765) 741-0057

Or via the Internet at: <http://www.modelaircraft.org>



IMPORTANT!!! Two of the most important things you can do to preserve the radio controlled aircraft hobby are to avoid flying near full-scale aircraft and avoid flying near or over groups of people.

SAFETY PRECAUTIONS

PROTECT YOUR MODEL, YOURSELF & OTHERS... FOLLOW THESE IMPORTANT SAFETY PRECAUTIONS

1. Your Factor 3D EP ARF should not be considered a toy, but rather a sophisticated, working model that functions very much like a full-size airplane. Because of its performance capabilities, the Factor 3D, if not assembled and operated

correctly, could possibly cause injury to yourself or spectators and damage to property.

2. You must assemble the model **according to the instructions**. Do not alter or modify the model, as doing so may result in an unsafe or unflyable model. In a few cases the instructions may differ slightly from the photos. In those instances the written instructions should be considered as correct.

3. You must take time to **build straight, true and strong**.

4. You must use an R/C radio system that is in first-class condition, and a correctly sized engine and components (fuel tank, wheels, etc.) throughout the building process.

5. You must correctly install all R/C and other components so that the model operates correctly on the ground and in the air.

6. You must check the operation of the model before **every** flight to insure that all equipment is operating and that the model has remained structurally sound. Be sure to check clevises or other connectors often and replace them if they show any signs of wear or fatigue.

7. If you are not an experienced pilot or have not flown this type of model before, we recommend that you get the assistance of an experienced pilot in your R/C club for your first flights. If you're not a member of a club, your local hobby shop has information about clubs in your area whose membership includes experienced pilots.

We, as the kit manufacturer, provide you with a top quality, thoroughly tested kit and instructions, but ultimately the quality and flyability of your finished model depends on how you build it; therefore, we cannot in any way guarantee the performance of your completed model, and no representations are expressed or implied as to the performance or safety of your completed model.

REMEMBER: Take your time and follow the instructions to end up with a well-built model that is straight and true.

DECISIONS YOU MUST MAKE

This is a partial list of items required to finish the Factor 3D EP ARF that may require planning or decision making before starting to build.

Radio Equipment

- A 4-channel radio system with four micro servos and receiver are required for this plane.

The servos and receiver shown in the manual are Futaba® S3156 Servos (FUTM0656) and the Futaba 617FS FASST™ 2.4GHz receiver (FUTL7627)

Transmitter

- 4-channel radio (minimum)

Receiver

- 617FS FASST 2.4 GHz receiver [FUTL7627]

Servos

- (4) Futaba® S3156 Servos [FUTM0656] [28 oz-in (2.0 kg-cm) @ 4.8 V of torque]

Connectors

- (1) "Y" harness [FUTM4130]
- (2) 16" extensions [FUTM3955]

Motor Recommendations

The Factor EP ARF comes with a mounting box for the Great Planes RimFire brushless out-runner motor. The motor has been tested with this plane and works well.

- Great Planes RimFire .10 (35-30-1250) Brushless Out-runner Motor [GPMG4595]

ESC (Electronic Speed Control)

A brushless ESC (electronic speed control) is required for the recommended motor set-up. We recommend using the:

- Great Planes Silver Series SS-35A Brushless ESC [GPMM1830]

Propeller

For our testing we used the:

- Great Planes 10 × 4.5 SF propeller. (GPMQ6660)
- APC 10 × 4.7 SF propeller. (APCQ5015)

Flight Battery

We recommend:

- Great Planes Power Series™ LiPo 2200 mAh, 11.1V, 30C battery (GPMP0861)

or

- Flight Power® 2200 mAh 11.1V (FPWP6198)

ADDITIONAL ITEMS REQUIRED

Required Adhesives & Building Supplies

This is the list of adhesives and building supplies required to finish the Factor 3D EP ARF. Order numbers are provided in parentheses.

- 1/2 oz. [15 g] Thin Pro CA (GPMR6001)
- 1/2 oz. [15 g] Medium Pro CA+ (GPMR6007)
- Drill bits: 1/16" [1.6 mm], 5/64" [2 mm]
- #1 Hobby knife (HCAR0105)
- #11 blades (5-pack, HCAR0211)
- Small T-pins (100, HCAR5100)

Optional Supplies and Tools

Here is a list of optional tools mentioned in the manual that will help you build the Factor 3D EP ARF 580 EP.

- Pro 30-minute epoxy (GPMR6047)
- Denatured alcohol (for epoxy clean up)
- 2 oz. [57 g] spray CA activator (GPMR6035)
- CA applicator tips (HCAR3780)
- CA debonder (GPMR6039)
- Epoxy brushes (6, GPMR8060)
- Mixing sticks (50, GPMR8055)
- Mixing cups (GPMR8056)
- Threadlocker thread locking cement (GPMR6060)
- AccuThrow™ Deflection Gauge (GPMR2405)
- CG Machine™ (GPMR2400)
- 21st Century® sealing iron [COCR2700]
- 21st Century iron cover [COVR2702]

IMPORTANT BUILDING NOTES

- There are two types of screws used in this kit:

Sheet Metal Screws are designated by a number and a length. For example #6 × 3/4" [19mm].

This is a number six screw that is 3/4" [19 mm] long.

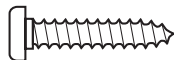

Machine Screws are designated by a number, threads per inch, and a length. For example 4-40 × 3/4" [19mm].

This is a number four screw that is 3/4" [19 mm] long with forty threads per inch.

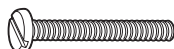

- When you see the term **test fit** in the instructions, it means that you should first position the part on the assembly **without using any glue**, then slightly modify or *custom fit* the part as necessary for the best fit.
- Whenever the term **glue** is written you should rely upon your experience to decide what type of glue to use. When a specific type of adhesive works best for that step, the instructions will make a recommendation.
- We recommend 30-minute epoxy only, because you will need the working time or the additional strength
- **Photos** and **sketches** are placed **before** the step they refer to. Frequently you can study photos in following steps to get another view of the same parts.

KIT INSPECTION

Before starting to build, take an inventory of this kit to make sure it is complete, and inspect the parts to make sure they are of acceptable quality. If any parts are missing or are not of acceptable quality, or if you need assistance with assembly, contact **Product Support**. When reporting defective or missing parts, use the part names exactly as they are written in the Kit Contents list.

Great Planes Product Support

3002 N Apollo Drive, Suite 1 Ph: (217) 398-8970, ext. 5
Champaign, IL 61822 Fax: (217) 398-7721

E-mail: airsupport@greatplanes.com

ORDERING REPLACEMENT PARTS

Replacement parts for the Great Planes Factor 3D EP ARF are available using the order numbers in the **Replacement Parts List** that follows. The fastest, most economical service can be provided by your hobby dealer or mail-order company.

To locate a hobby dealer, visit the Hobbico web site at www.hobbico.com. Choose "Where to Buy" at the bottom of the menu on the left side of the page. Follow the instructions provided on the page to locate a U.S., Canadian or International dealer. If a hobby shop is not available, replacement parts may also be ordered from Tower Hobbies at www.towerhobbies.com, or by calling toll free (800) 637-6050.

Parts may also be ordered directly from Hobby Services by calling (217) 398-0007, or via facsimile at (217) 398-7721, but full retail prices and shipping and handling charges will apply. Illinois and Nevada residents will also be charged sales tax. If ordering via fax, include a Visa or MasterCard number and expiration date for payment.

Mail parts orders and payments by personal check to: **Hobby Services**
3002 N Apollo Drive, Suite 1
Champaign IL 61822

Be certain to specify the order number exactly as listed in the **Replacement Parts List**. Payment by credit card or personal check only; no C.O.D.

If additional assistance is required for any reason contact Product Support by e-mail at productsupport@greatplanes.com, or by telephone at (217) 398-8970.

REPLACEMENT PARTS LIST	
Order No.	Description
GPMA2100	Fuselage
GPMA2101	Wing Set
GPMA2102	Tail Surface Set
GPMA2103	Canopy Hatch
GPMA2104	Cowl
GPMA2105	Landing Gear
GPMA2106	Wheel Pants
GPMA2107	Spinner
GPMA2108	Tail Wheel Wire
GPMA2109	Wing Bolts
GPMA2110	Wing Tube
GPMA2111	Decal Sheet

KIT CONTENTS

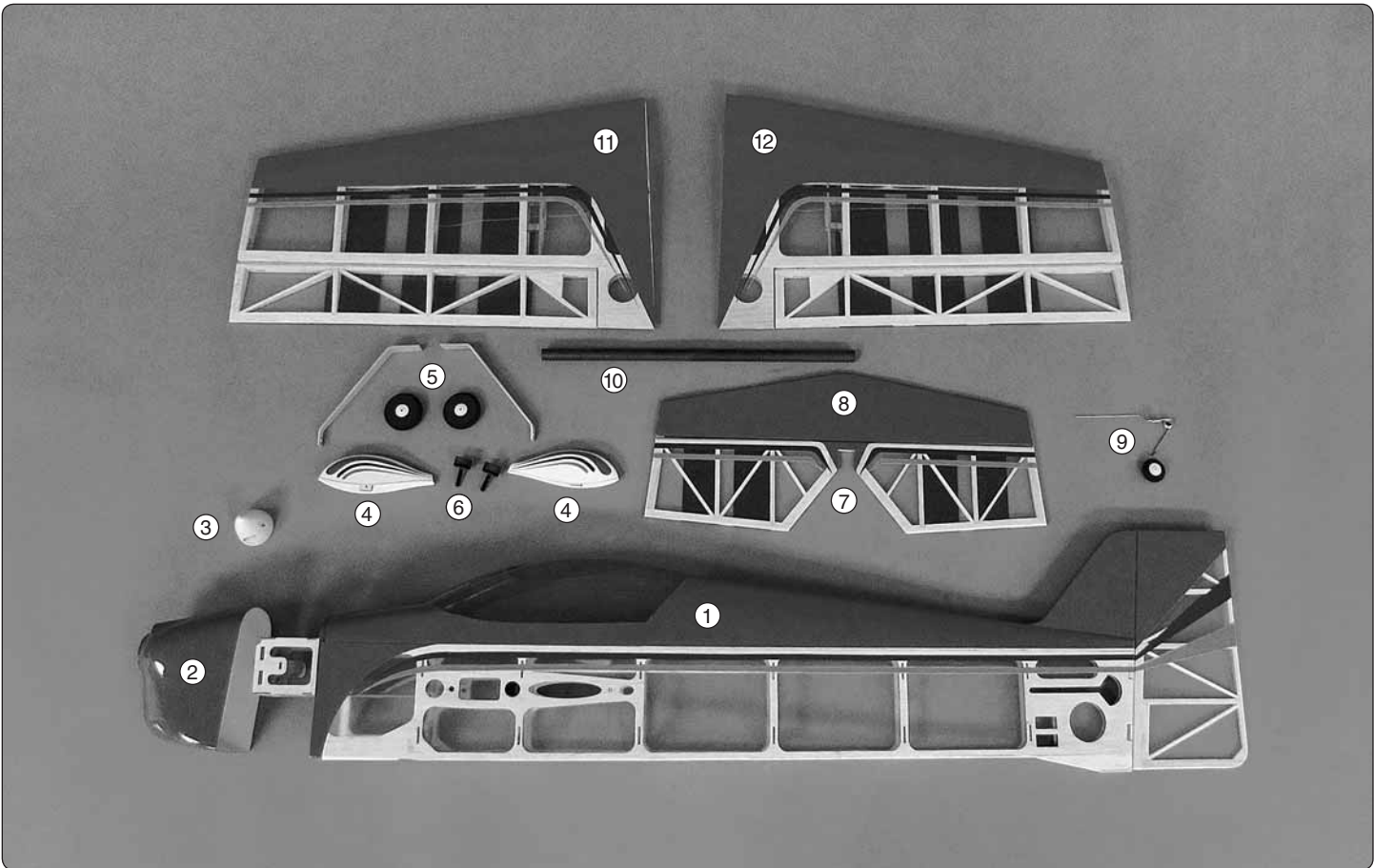

Kit Contents

- | | | |
|----------------|---------------|-------------------|
| 1. Fuselage | 5. Wheels | 9. Tail Wheel Set |
| 2. Cowl | 6. Wing Bolts | 10. Wing Tube |
| 3. Spinner | 7. Elevator | 11. Left Wing |
| 4. Wheel Pants | 8. Stabilizer | 12. Right Wing |

PREPARATIONS

❑ 1. If you have not done so already, remove the major parts of the kit from the box and inspect for damage. If any parts are damaged or missing, contact Product Support at the address or telephone number listed in the "Kit Inspection" section on page 4.

❑ 2. Remove the tape and separate the elevators from the stab. Use a covering iron with a covering sock on medium heat to tighten the covering on the wings, fuselage, etc. if necessary. Apply pressure over sheeted areas to **thoroughly** bond the covering to the wood. **Caution:** The Factor 3D EP ARF was designed to be strong where needed, but light weight for excellent flight performance. Care must be taken when assembling the plane to avoid damage.

ASSEMBLE THE WINGS

Install the Ailerons

Do the right wing first so your work matches the photos the first time through.

Install the Aileron Servos and Pushrods



❑ ❑ 1. Inside the servo bay a string is taped. Carefully remove the tape and string from the servo bay. Tie the string to the servo lead. Pull the string and the servo lead through the wing. Untie the string from the lead.



❑ ❑ 2. Install the servo into the servo opening. Drill a 1/16" [1.6mm] hole through the servo mount, into the wood in the

wing. Install and then remove a servo mounting screw into each of the holes you have drilled. Apply a drop of thin CA into the holes to harden the threads. Once the glue has cured install the servo into the servo opening. Center the servo and then install a servo arm as shown. The arm should be pointing towards the wing root.

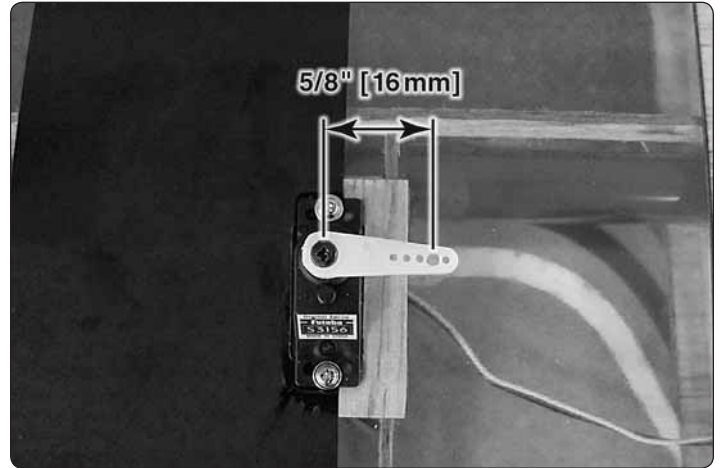

❑ ❑ 3. Drill a 5/64" [2 mm] hole through the hole in the servo arm as shown.

❑ ❑ 4. Thread a nylon clevis, 20 turns, onto a 6" [152 mm] wire pushrod.

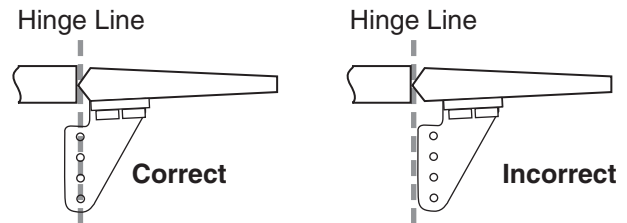

Refer to this picture for steps 5-7.

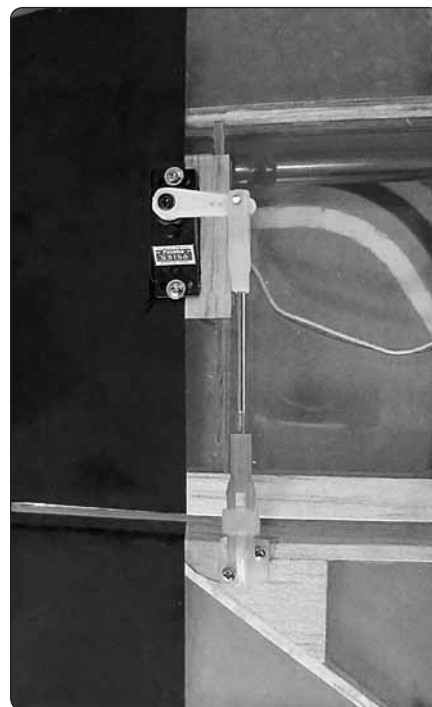

❑ ❑ 5. Cut the mounting plate from the control horn. Attach the clevis in the outer hole of a nylon control horn. Place the control horn in line with hole you drilled in the servo arm. When positioned properly the control horn will rest on a hardwood plate in the aileron. Mark the location of the mounting holes onto the aileron. Drill a 1/16" [1.6 mm] hole on the marks, drilling through the plywood plate but not through the top of the aileron.

❑ 6. Install and then remove a #2 × 3/8" [10 mm] screw into each of the holes you have drilled. Apply a drop of thin CA into the holes to harden the threads. Once the glue has cured, secure the control horn to the aileron with the screws.

❑ 7. Slide a silicone clevis retainer over the clevis. With the aileron servo and the aileron centered, mark the aileron pushrod where it crosses the aileron servo arm. Make a 90° bend at the mark. Cut the pushrod 3/8" [9.5 mm] past the bend. Attach the pushrod to the aileron servo arm with a nylon Faslink.

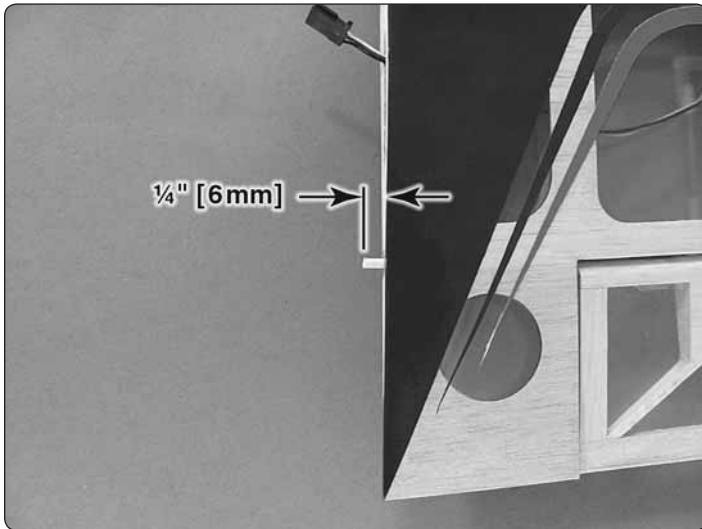

❑ 8. Locate a 1/8" × 1/2" [3 × 13 mm] nylon pin. Glue it into the hole at the trailing edge of the root rib. Approximately 1/4" [6 mm] of the pin should extend from the root rib.

❑ 9. Repeat steps 1-8 for the left wing panel.

ASSEMBLE THE FUSELAGE

Install the Main Landing Gear

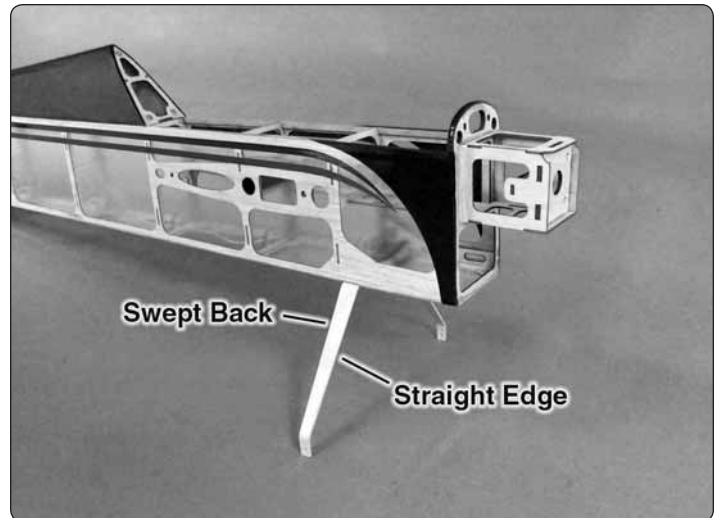
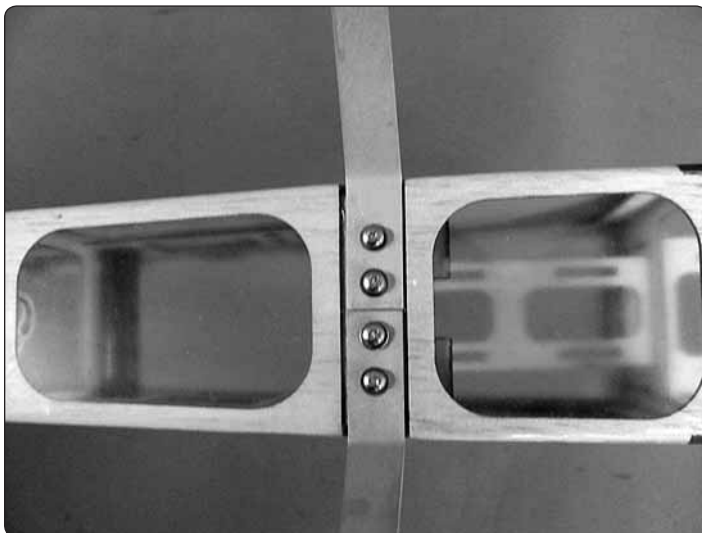

❑ 1. Attach the two main landing gear legs to the **fuselage** with four 4-40 × 3/8" [3 × 10 mm] screws, #4 lock washers and #4 flat washers.

You will complete the installation of the wheels and wheel pants in a later step. Installing the landing gear legs now will make handling the fuselage easier during the assembly of the fuselage.

Install the Elevator & Rudder Servos

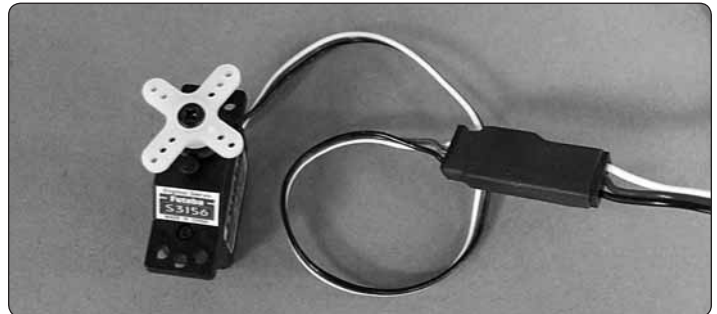

❑ 1. Install a 16" [400 mm] servo extension to both the elevator servo and the rudder servo. Secure the extension to the lead with tape, a piece of shrink tube (not included) or some other method to keep them from coming unplugged.

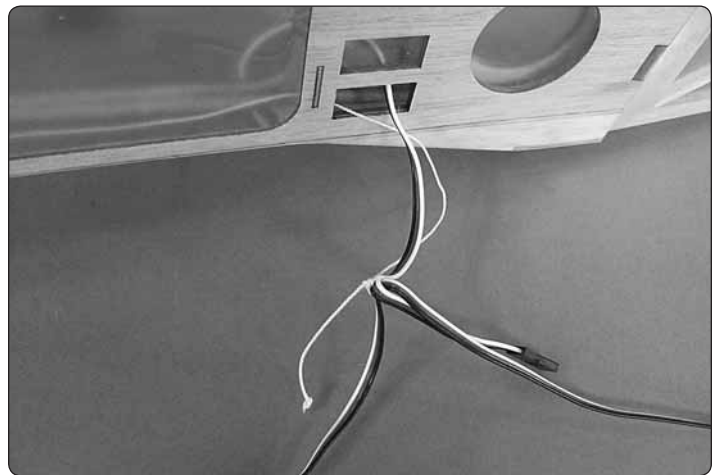

❑ 2. Inside the fuselage there is a string running through the fuselage from the back to the front. The string is taped in place

in the back of the fuselage. Take the string from the back of the fuselage and pull it through the lower servo opening on the left side of the fuselage. From the right side of the fuselage install the elevator servo lead through the servo opening and out of the fuselage through the rudder servo opening on the left side of the fuselage. Tie both the rudder and elevator servo leads with the string.



□ 3. From the front of the fuselage pull the servo leads through the fuselage with the string. Tape the servo leads to the fuselage to prevent them from falling back into the fuselage.

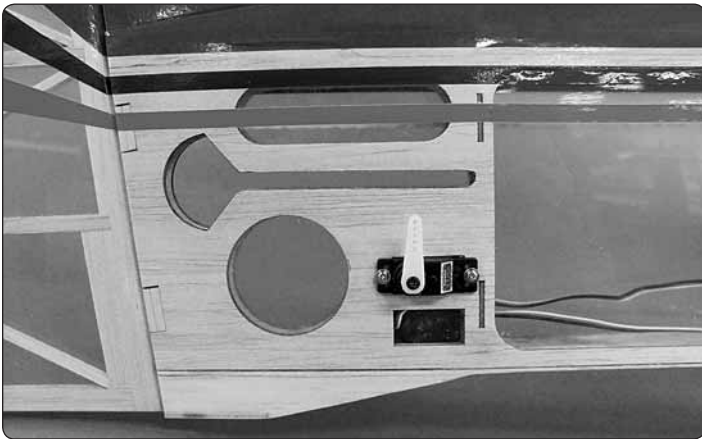

□ □ 4. Install the elevator servo into the servo opening on the right side of the fuselage. Drill a 1/16" [1.6 mm] hole through the mounting holes of the servo into the servo mounting rails in the fuselage.

□ □ 5. Install and then remove a servo mounting screw into each of the holes. Apply a drop of thin CA into the holes to harden the threads. Once the glue has hardened, install the servo into the servo opening. Center the servo and then install a servo arm as shown.

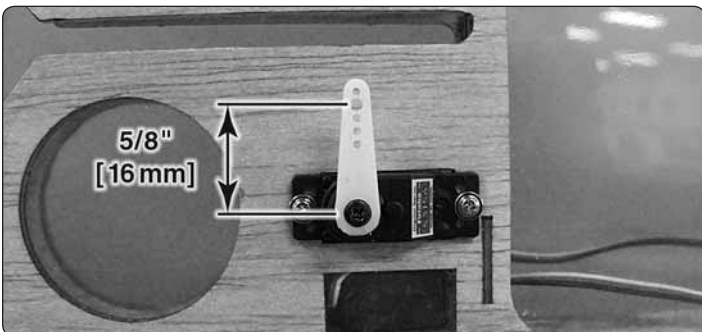

□ □ 6. Drill a 5/64" [2 mm] hole through the hole in the servo arm as shown.

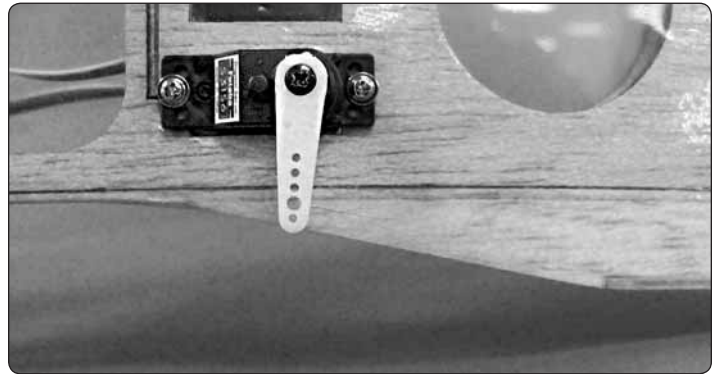
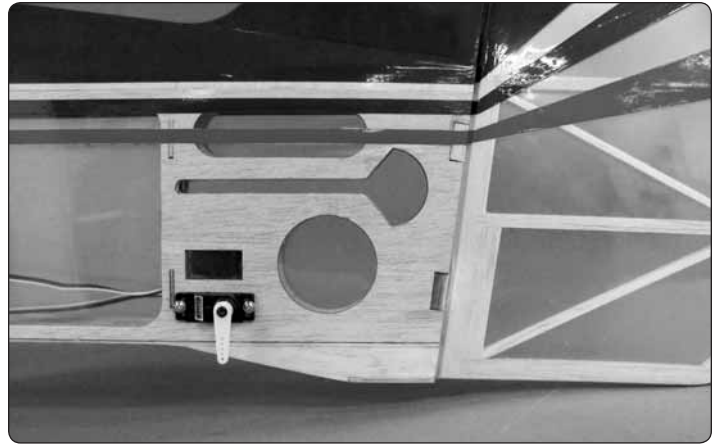

□ 7. Repeat steps 4 - 6 for the rudder servo.

Install the Stab and Elevator

If you have not yet removed the canopy, remove it by sliding it forward and then lifting the back.

□ 1. Temporarily install the wing tube into the fuselage and the wings onto the wing tubes. Secure the wing panels to the fuselage with the nylon wing bolts.

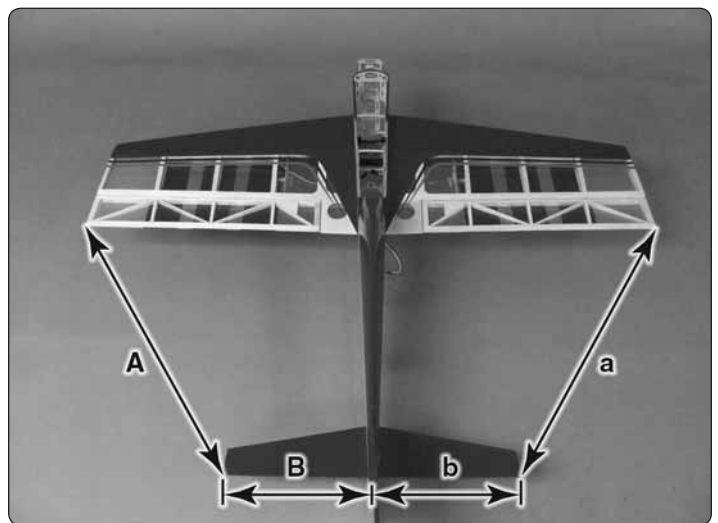

□ 2. Temporarily install the horizontal stabilizer into the opening in the back of the fuselage. Position it so that the distance from the tip of the wing to the tip of the stab is of equal distance.

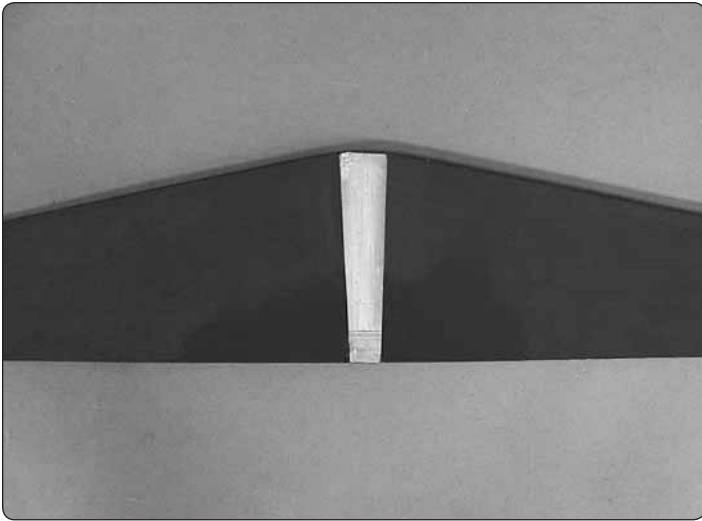

❑ 3. Once properly positioned mark the sides of the fuselage onto the top and bottom of the stab with a fine tip felt tip marker. Remove the stab from the fuselage and cut the covering from the center of the stab as shown. When cutting the covering **DO NOT CUT INTO THE HORIZONTAL STAB! THIS WILL WEAKEN THE STRUCTURE.** You may want to use the EXPERT TIP that follows for cutting the covering away.



HOW TO CUT COVERING FROM Balsa

Use a soldering iron to cut the covering from the stab. The tip of the soldering iron doesn't have to be sharp, but a fine tip does work best. Allow the iron to heat fully.



Use a straightedge to guide the soldering iron at a rate that will just melt the covering and not burn into the wood. The hotter the soldering iron, the faster it must travel to melt a fine cut. Peel off the covering.

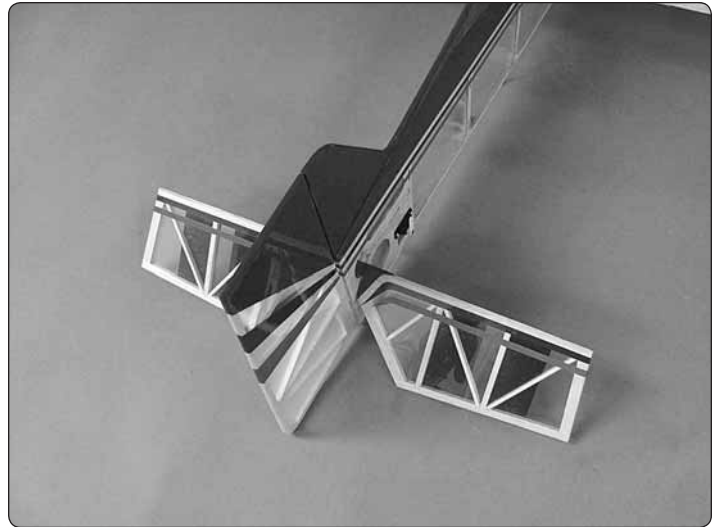

❑ 4. Install the elevator into the slot in the back of the fuselage. Re-install the stab back into the fuselage.

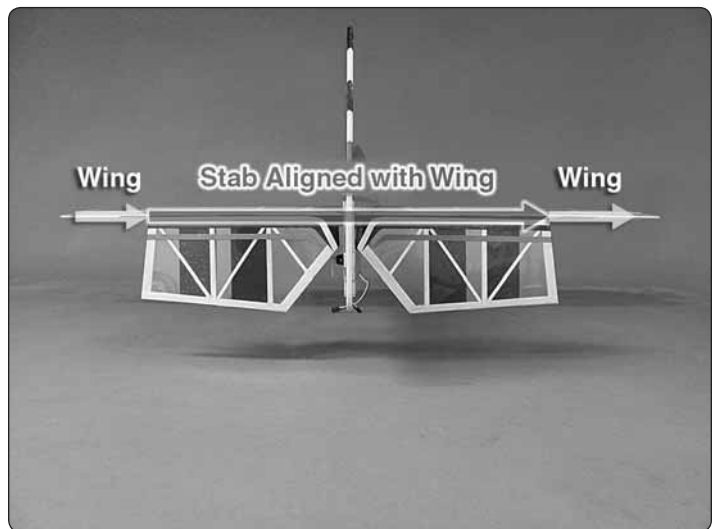

❑ 5. Glue the stab to the fuselage. Check to be sure the stab is aligned with the wing before the glue dries. Leave the fuselage undisturbed until the glue dries.

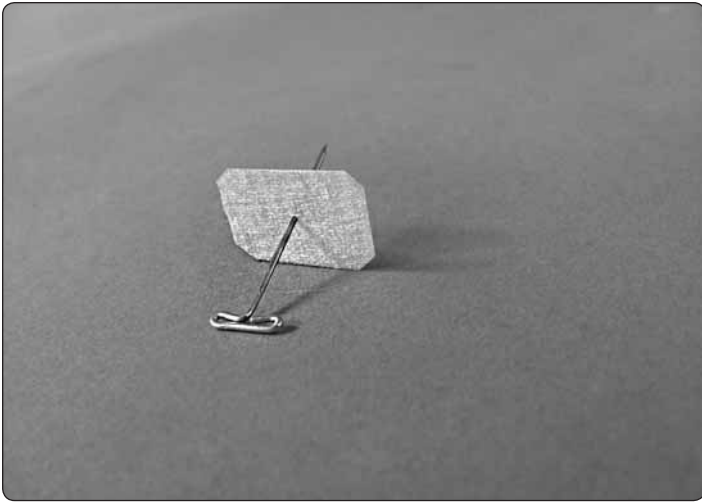

❑ 6. Locate six hinges. Insert a T-pin through the center of each hinge.

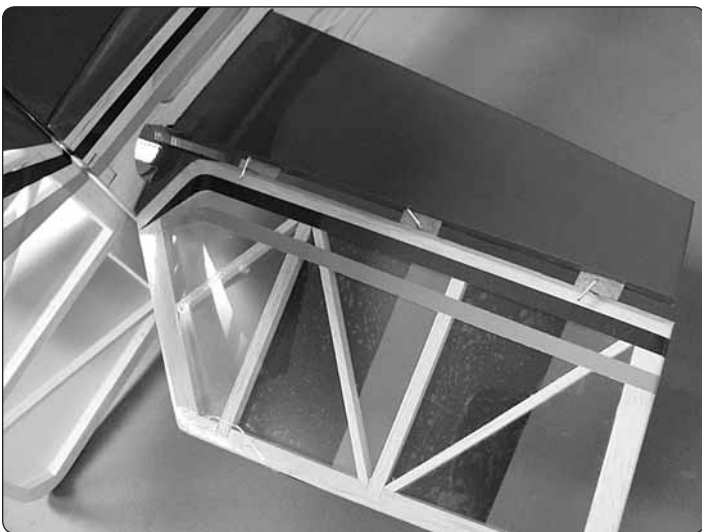

❑ 7. Install the hinges into the slots in the elevator and then slide the elevator onto the stab.

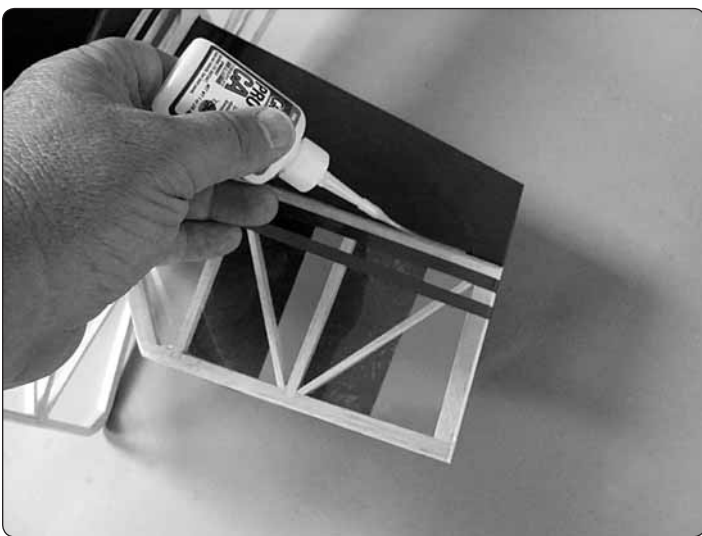

❑ 8. Apply a couple of drops of thin CA glue onto the top and bottom of each of the hinges. Allow the glue to harden. After the glue has dried, pull on the elevator to be sure the hinges are secure.

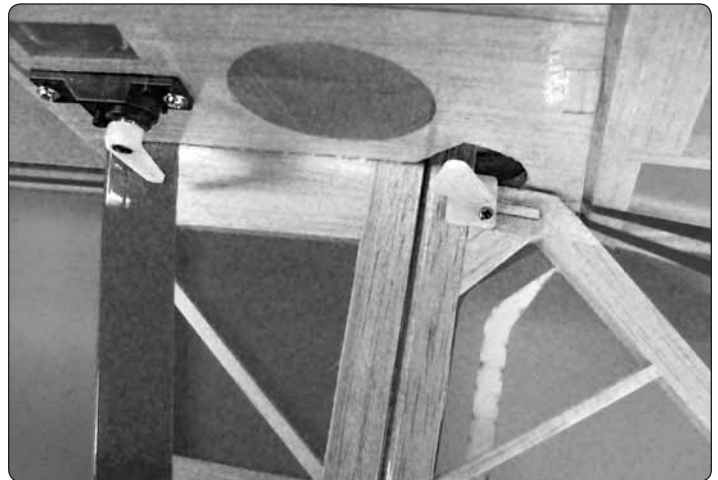
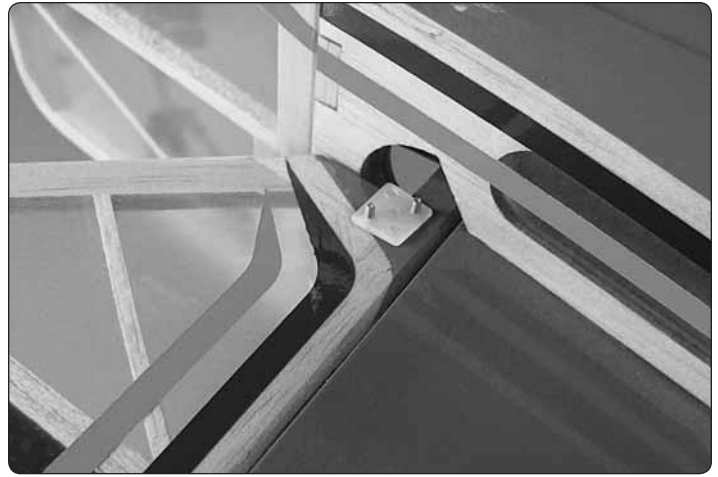

❑ 9. Cut the mounting plate from the control horn. Place the control horn in line with the elevator servo arm. Position the horn on the elevator the same as was done with the ailerons. Mark the location of the mounting holes onto the aileron. Drill a 1/16" [1.6 mm] hole on the marks, drilling through the elevator. Install two 1/16" × 3/8" machine screws through the control horn and the elevator, securing them with the nylon plate on the top of the elevator.

❑ 10. Thread a nylon clevis, 20 turns, onto a 6" [152 mm] wire pushrod.

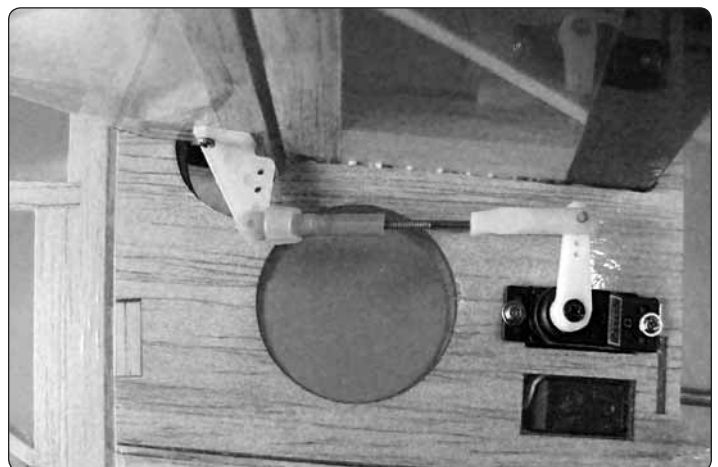

❑ 11. Slide a silicone clevis retainer over the clevis. With the elevator servo and the elevator centered, mark the aileron

pushrod where it crosses the aileron servo arm. Make a 90° bend at the mark. Cut the pushrod 3/8" [9.5 mm] past the bend. Attach the pushrod to the elevator servo arm with a nylon Faslink.

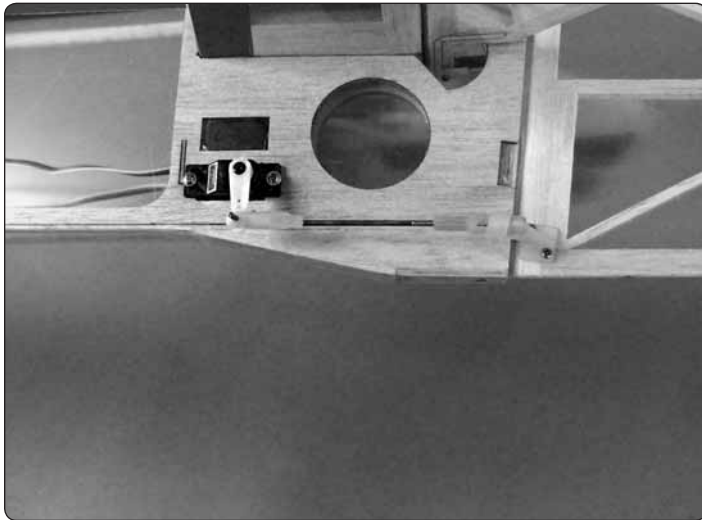

□ 12. Repeat steps 9-11 for the rudder pushrod installation.

Install the Motor, Speed Control and Receiver

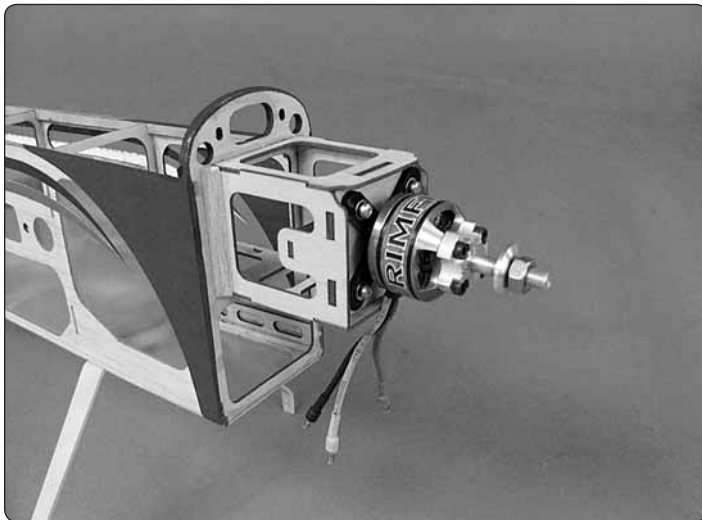

□ 1. Assemble your motor following the instructions that came with it. Install the motor to the firewall with four 4-40 × 3/8" [3 × 10 mm] machine screws, #4 [3 mm] lock washers and #4 [3 mm] flat washers. Be sure to apply a drop of thread locker to the threads on each screw.

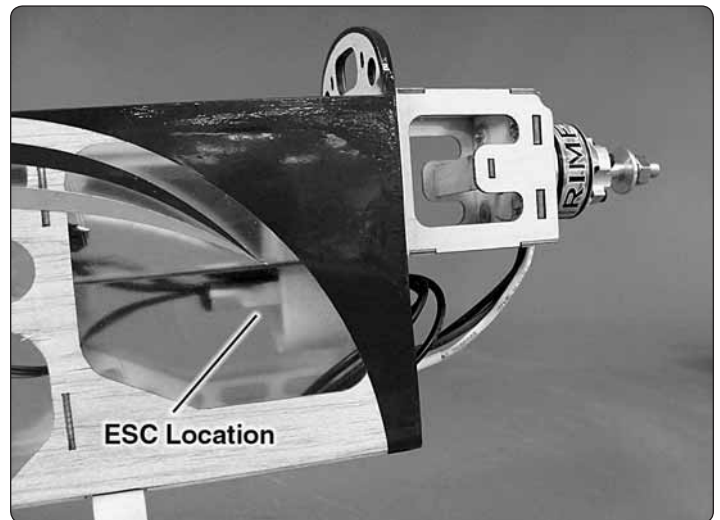

□ 2. Cut a piece of the adhesive-backed hook and loop fastener to fit the speed control and apply one side of it to one side of the speed control and the other half to the bottom of the battery tray in the fuselage. Install the Velcro strap (without adhesive backing) through the slots in the battery tray and around the speed control. Plug the leads from the motor into the speed control.

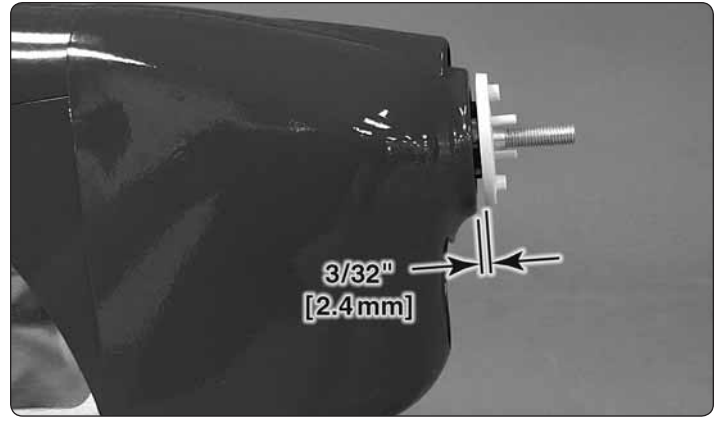
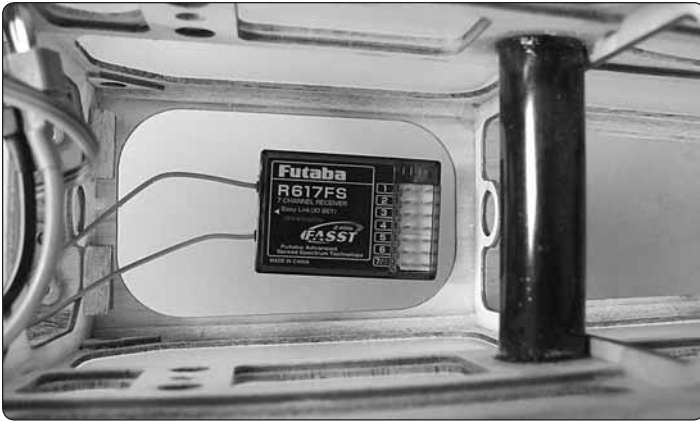

- 3. Cut the remaining adhesive-backed hook and loop fastener to fit the receiver. Apply the receiver inside the fuselage. Orient the antenna according to the receiver's instructions.
- 4. Plug the servo leads, aileron "Y" harness and the speed control into the appropriate channels in the receiver.
- 5. Test run the motor to be sure the propeller is turning in the correct direction.

- 3. Slide the cowl onto the fuselage. Slide the spinner back plate onto the motor shaft. Depending on your brand of motor you may need to enlarge the hole in the back plate. When the cowl is properly positioned the distance between the spinner back plate and the front of the cowl should be $3/32$ " [2.4 mm].

Install the Cowl

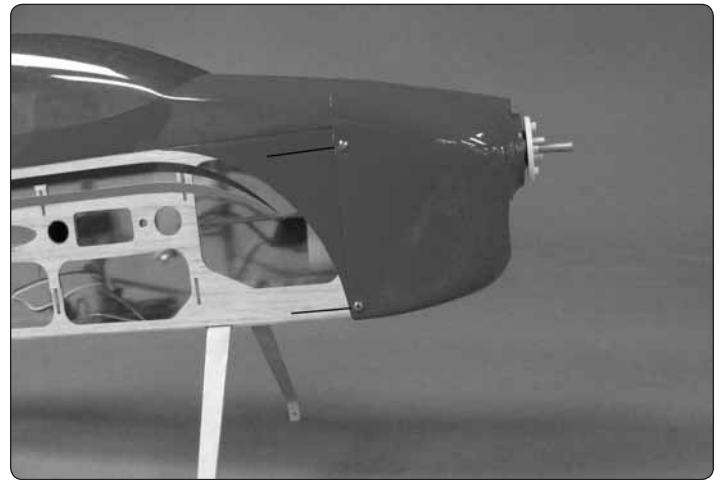
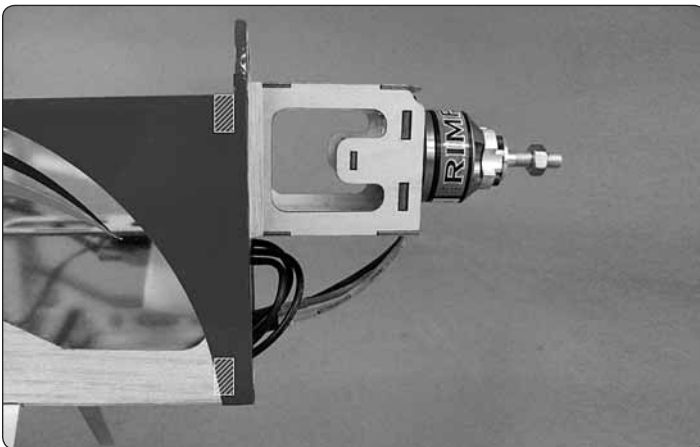

- 1. There is a small plywood plate inside the fuselage for the cowl mounting screws. The photo illustrates the approximate position of the plywood plates.

- 4. Using the lines you put on the fuselage as a reference, drill a $1/16$ " [1.6 mm] hole through the cowl and into the plywood plate in the fuselage. Secure the cowl with four $3/32$ " \times $5/16$ " [$2.5 \times 8\text{ mm}$] washer head screws.

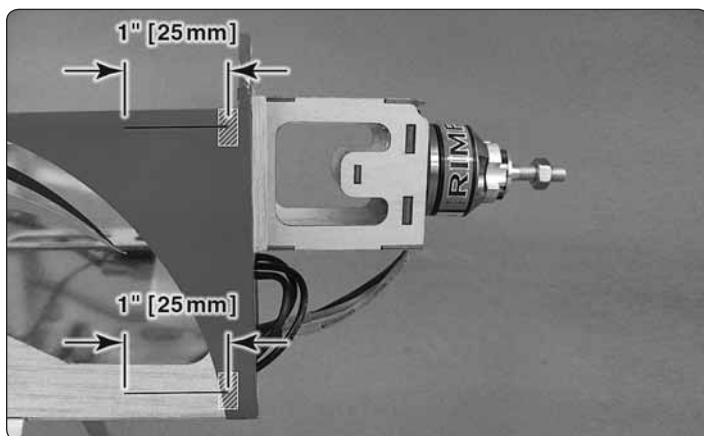

- 5. Do not install the propeller at this time. For safety, this will be done after the plane is completed.

- 2. From the center of the plywood plate draw a line back 1 " [25 mm] with a felt tip pen.

Install the Wheel and Wheel Pants

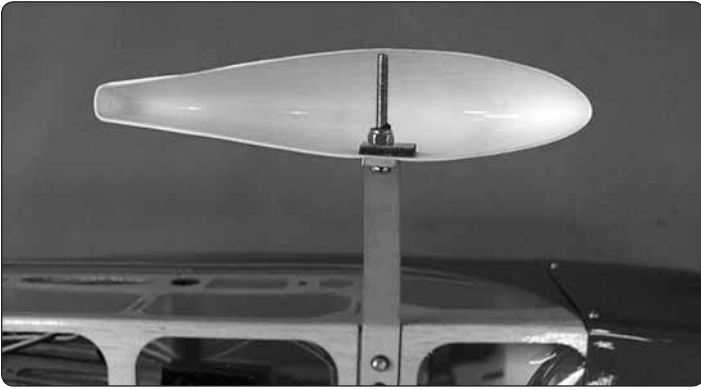

☐ ☐ 1. Secure the wheel pant to the landing gear with a 2-56 \times 1" [2 \times 25 mm] screw and 2-56 nylon stop nut.

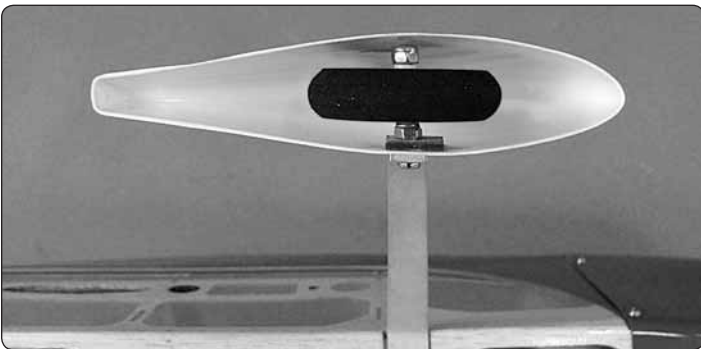

☐ ☐ 2. Slide the wheel onto screw. Install another nylon stop nut onto the end of the screw to secure the wheel.

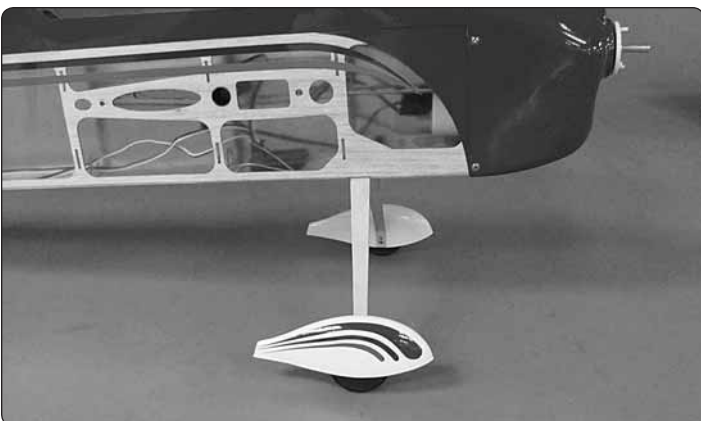
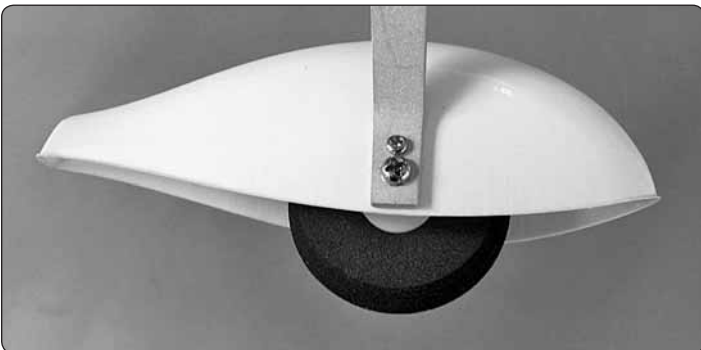

☐ ☐ 3. Set the position of the wheel pants and secure the pant to the landing gear with a $1/16"$ \times $1/4"$ [1.6 \times 6 mm] wood screw. Do this for both wheel pants.

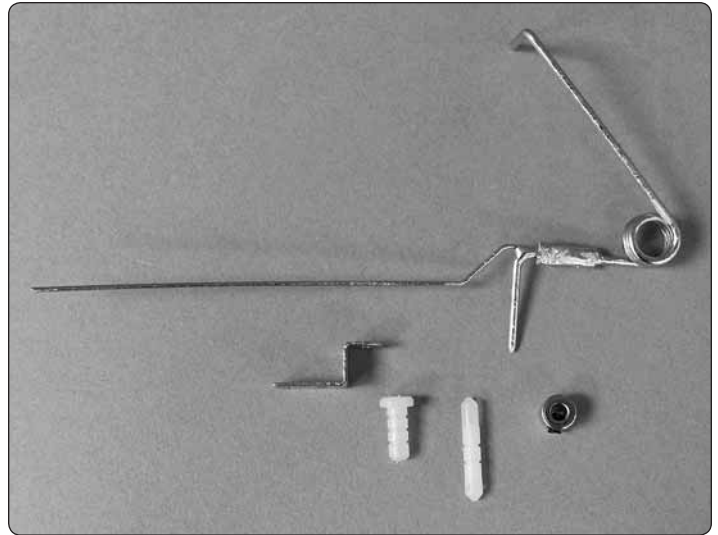

☐ 3. Locate the parts shown. Install the set screw into the wheel collar.

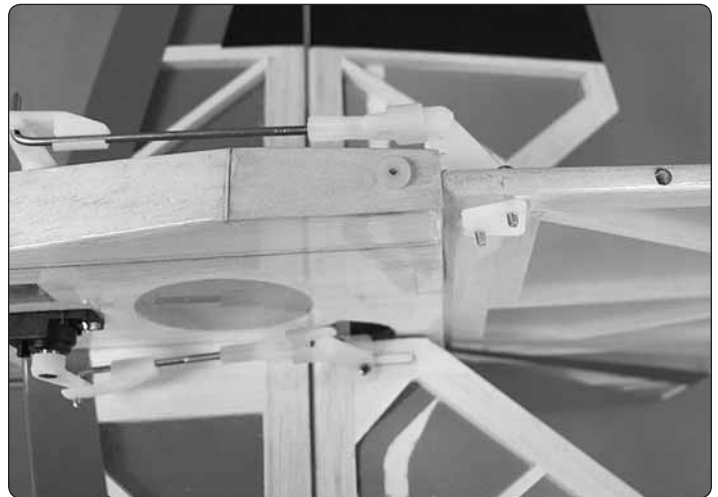

☐ 4. Install the nylon bushing into the fuselage.

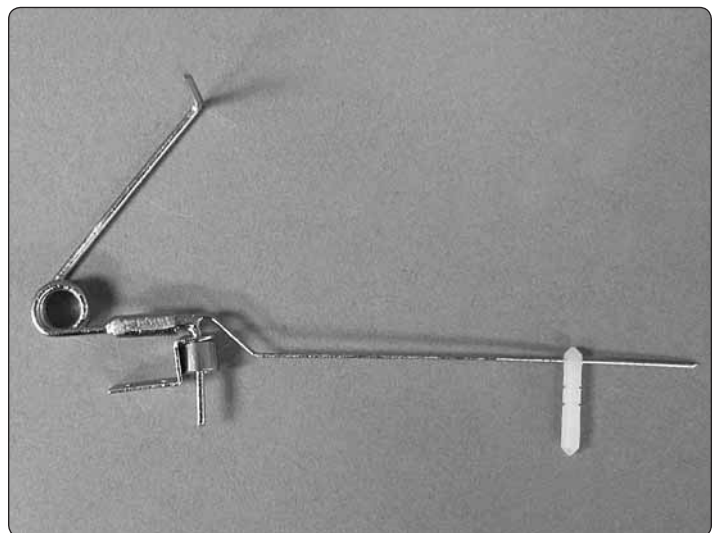

☐ 5. Assemble the remaining components as shown here.

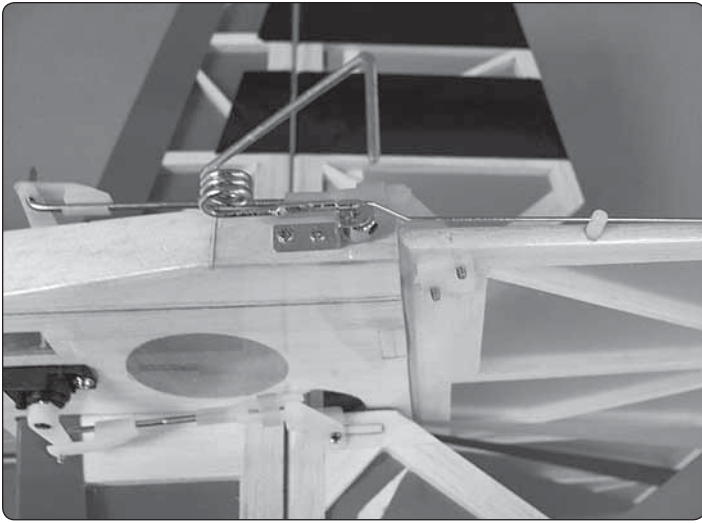

❑ 6. Place the metal bracket against the plywood plate. Drill a 1/16" [1.6 mm] hole through the holes in the bracket and into the plywood plate. Secure the bracket to the fuselage with two 1/16" × 1/2" [1.6 × 13 mm] screws. Insert the nylon pin on the tail wheel wire into the hole in the bottom of the rudder. Glue it to the rudder with a couple of drops of thin CA glue.

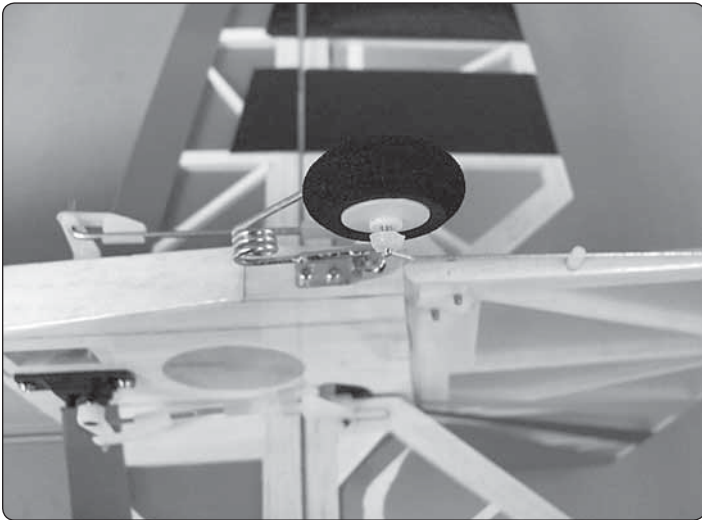

❑ 7. Slide the tail wheel onto the tail wheel wire and secure it with the nylon retainer.

Apply the Decals

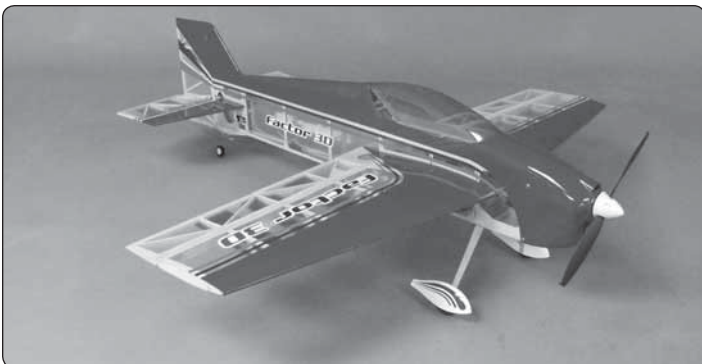

This photograph and the box photographs show the location of the decals on the airplane. Refer to these for the exact

placement of the decals. The following tips may be useful for applying them.

- ❑ 1. Be certain the model is clean and free from oily fingerprints and dust. Prepare a dishpan or small bucket with a mixture of liquid dish soap and warm water—about one teaspoon of soap per gallon of water. Submerge the decal in the soap and water and peel off the paper backing. **Note:** Even though the decals have a “sticky-back” and are not the water transfer type, submersing them in soap & water allows accurate positioning and reduces air bubbles underneath.
- ❑ 2. Position decals on the model. Holding the decal down, use a paper towel to wipe most of the water away.
- ❑ 3. Use a piece of soft balsa or something similar to squeegee remaining water from under the decal. Apply the rest of the decals the same way.

GET THE MODEL READY TO FLY

Check the Control Directions

- ❑ 1. Turn on the transmitter and receiver and center the trims. If necessary, remove the servo arms from the servos and reposition them so they are centered. Reinstall the screws that hold on the servo arms.
- ❑ 2. With the transmitter and receiver still on, check all the control surfaces to see if they are centered. If necessary, adjust the clevises on the pushrods to center the control surfaces.

4-CHANNEL RADIO SET UP (STANDARD MODE 2)

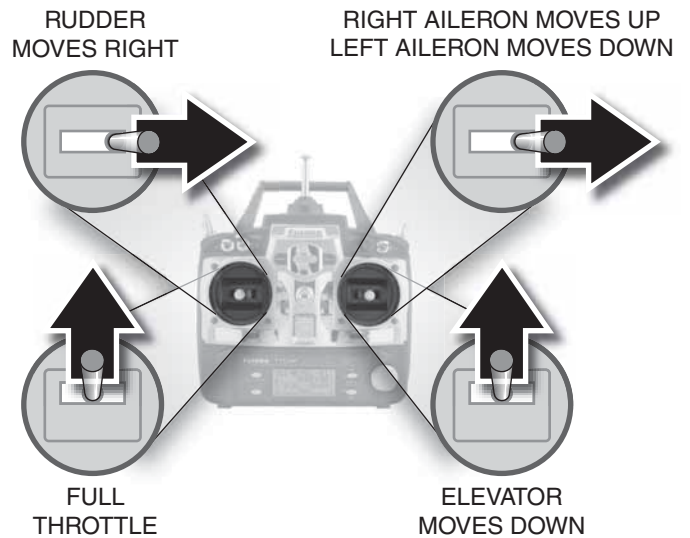

- ❑ 3. Make certain that the control surfaces and the throttle respond in the correct direction as shown in the diagram. If any of the controls respond in the wrong direction, use the servo reversing in the transmitter to reverse the servos connected to those controls. Be certain the control surfaces have remained centered. Adjust if necessary.

Set the Control Throws

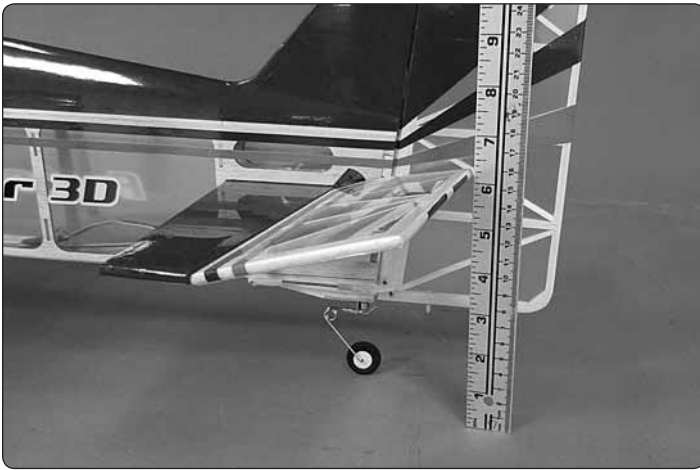

Use a ruler to accurately measure and set the control throw of each control surface as indicated in the chart that follows. If your radio does not have dual rates, we recommend setting the throws at the **low** rate setting.

NOTE: The throws are measured at the **widest part** of the elevators, rudder and ailerons.

These are the recommended control surface throws:

	LOW	HIGH	3D
ELEVATOR Up & Down	1-1/4" [32 mm] 19°	1-3/4" [44 mm] 27°	2-1/4" [57 mm] 35°
RUDDER Right & Left	1-1/4" [32 mm] 16°	1-1/2" [38 mm] 19°	2-3/4" [70 mm] 36°
AILERONS Up & Down	5/8" [16 mm] 13°	1" [25 mm] 21°	1-1/4" [32 mm] 27°

We also put exponential into the High rates and the 3D rates to make the control throws less sensitive around neutral. These can be set up to your own preference and flying style. We put 20% to 30% in the high rate and 50% to 60% in the 3D rates.

IMPORTANT: The Factor 3D EP has been **extensively** flown and tested to arrive at the throws at which it flies best. Flying your model at these throws will provide you with the greatest chance for successful first flights. If, after you have become accustomed to the way Factor 3D EP flies, you would like to change the throws to suit your taste, that is fine. However, too much control throw could make the model difficult to control, so remember, "more is not always better."

Finish the Model

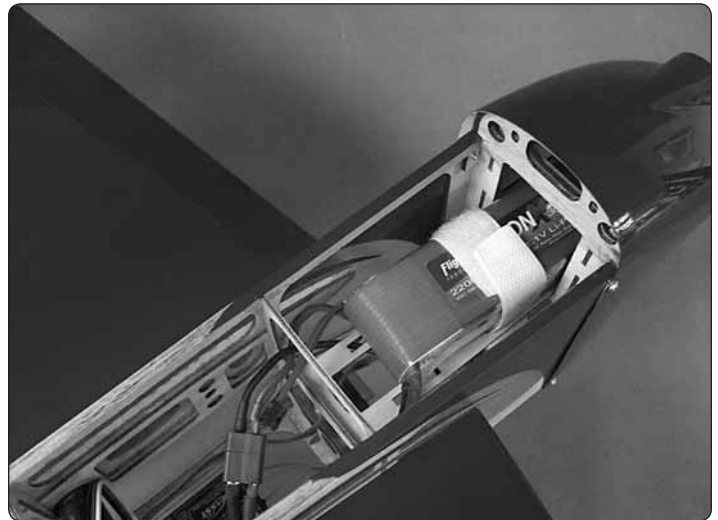

1. Insert a flight battery in the fuselage and use the hook and loop material to hold the battery in position. Do not connect the battery to the ESC while balancing the model.
2. Install the propeller and spinner to the motor shaft.

Balance the Model (C.G.)

More than any other factor, the C.G. (center of gravity/balance point) can have the greatest effect on how a model flies and could determine whether or not your first flight will be successful. If you value your model and wish to enjoy it for many flights, **DO NOT OVERLOOK THIS IMPORTANT PROCEDURE.** A model that is not properly balanced may be unstable and possibly unflyable.

At this stage the model should be in ready-to-fly condition with all of the systems in place including the motor and battery, landing gear, covering and paint, and the radio system.

1. Use a felt-tip pen or 1/8" [3 mm]-wide tape to accurately mark the C.G. on the top of the wing at the side of the fuselage. The C.G. is located 4-1/4" [108 mm] back from the leading edge of the wing at the side of the fuselage.

This is where your model should balance for the first flights. Later, you may wish to experiment by shifting the C.G. up to 3/16" [5 mm] forward or 1/4" [6 mm] back to change the flying characteristics. Moving the C.G. forward may improve the smoothness and stability, but the model may then require more speed for takeoff and make it more difficult to slow for landing. Moving the C.G. aft makes the model more maneuverable, but could also cause it to become too difficult to control. In any case, **start at the recommended balance point** and do not at any time balance the model outside the specified range.

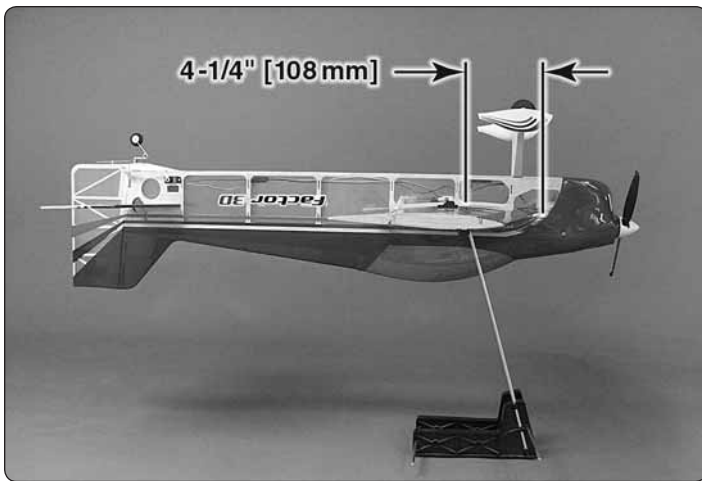

2. With the wing attached to the fuselage, all parts of the model installed (ready to fly) and the battery installed, lift it at the balance point you marked.

3. If the tail drops, the model is “tail heavy” and the battery pack and/or receiver must be shifted forward or weight must be added to the nose to balance. If the nose drops, the model is “nose heavy” and the battery pack must be shifted aft or weight must be added to the tail to balance. If additional weight is required, use Great Planes (GPMQ4485) “stick-on” lead. A good place to add stick-on nose weight is to the motor box (don’t attach weight to the cowl—it is not intended to support weight). Begin by placing incrementally increasing amounts of weight on the fuse over the motor box until the model balances. Once you have determined the amount of weight required, it can be permanently attached.

Note: Do not rely upon the adhesive on the back of the lead weight to permanently hold it in place. Over time the adhesive may soften and cause the weight to fall off. Use #2 sheet metal screws, RTV silicone or epoxy to permanently hold the weight in place.

4. **IMPORTANT:** If you found it necessary to add any weight, recheck the C.G. after the weight has been installed.

Balance the Model Laterally

1. With the wing level, have an assistant help you lift the model by the engine propeller shaft and the bottom of the fuse under the TE of the fin. Do this several times.

2. If one wing always drops when you lift the model, it means that side is heavy. Balance the airplane by adding weight to the other wing tip. **An airplane that has been laterally balanced will track better in loops and other maneuvers.**

PREFLIGHT

Identify Your Model

No matter if you fly at an AMA sanctioned R/C club site or if you fly somewhere on your own, you should always have your name, address, telephone number and AMA number on or

inside your model. It is **required** at all AMA R/C club flying sites and AMA sanctioned flying events. Fill out the identification tag on page 19 and place it on or inside your model.

Charge the Batteries

Follow the battery charging instructions that came with your radio control system to charge the batteries. You should always charge your transmitter batteries the night before you go flying, and at other times as recommended by the radio manufacturer.

Charge the motor battery following the instructions that came with the battery. Be sure to use the appropriate charger that is recommended for the battery.

Range Check

Ground check the operational range of your radio before the first flight of the day. With the transmitter antenna collapsed and the receiver and transmitter on, you should be able to walk at least 100 feet away from the model and still have control. Have an assistant stand by your model and, while you work the controls, tell you what the control surfaces are doing. Repeat this test **with the motor running** at various speeds with an assistant holding the model, using hand signals to show you what is happening. If the control surfaces do not respond correctly, **do not fly!** Find and correct the problem first. Look for loose servo connections or broken wires, corroded wires on old servo connectors, poor solder joints in your battery pack or a defective cell, or a damaged receiver crystal from a previous crash. The problem may be the location of the antenna. The antenna should be as far away from the ESC and battery as possible.

MOTOR SAFETY PRECAUTIONS

Failure to follow these safety precautions may result in severe injury to yourself and others.

- Get help from an experienced pilot when learning to operate electric motors.
- Use safety glasses when running electric motors.
- Do not run the motor in an area of loose gravel or sand; the propeller may throw such material in your face or eyes.
- Keep your face and body as well as all spectators away from the plane of rotation of the propeller as you run the motor.
- Keep these items away from the prop: loose clothing, shirt sleeves, ties, scarfs, long hair or loose objects such as pencils or screwdrivers that may fall out of shirt or jacket pockets into the prop.
- The motor gets hot! Do not touch it during or right after operation.
- When working on your plane, remove the propeller if the motor battery will be connected.
- Always remove the motor battery from the plane when charging.

- Follow the charging instructions included with your charger for charging LiPo batteries. LiPo batteries can cause serious damage if misused.
- Never charge LiPo batteries unattended.

AMA SAFETY CODE EXCERPTS

Read and abide by the following excerpts from the Academy of Model Aeronautics Safety Code. For the complete Safety Code refer to *Model Aviation* magazine, the AMA web site or the Code that came with your AMA license.

General

- 1) I will not fly my model aircraft in sanctioned events, air shows, or model flying demonstrations until it has been proven to be airworthy by having been previously, successfully flight tested.
- 2) I will not fly my model aircraft higher than approximately 400 feet within 3 miles of an airport without notifying the airport operator. I will give right-of-way and avoid flying in the proximity of full-scale aircraft. Where necessary, an observer shall be utilized to supervise flying to avoid having models fly in the proximity of full-scale aircraft.
- 3) Where established, I will abide by the safety rules for the flying site I use, and I will not willfully and deliberately fly my models in a careless, reckless and/or dangerous manner.
- 5) I will not fly my model unless it is identified with my name and address or AMA number, on or in the model. Note: This does not apply to models while being flown indoors.
- 7) I will not operate models with pyrotechnics (any device that explodes, burns, or propels a projectile of any kind).

Radio Control

- 1) I will have completed a successful radio equipment ground check before the first flight of a new or repaired model.
- 2) I will not fly my model aircraft in the presence of spectators until I become a qualified flier, unless assisted by an experienced helper.
- 3) At all flying sites a straight or curved line(s) must be established in front of which all flying takes place with the other side for spectators. Only personnel involved with flying the aircraft are allowed at or in the front of the flight line. Intentional flying behind the flight line is prohibited.
- 4) I will operate my model using only radio control frequencies currently allowed by the Federal Communications Commission.
- 5) **I will not knowingly operate my model within three miles of any pre-existing flying site except in accordance with the frequency sharing agreement listed [in the complete AMA Safety Code].**
- 9) Under no circumstances may a pilot or other person touch a powered model in flight; **nor should any part of the model other than the landing gear, intentionally touch the ground, except while landing.**

CHECK LIST

During the last few moments of preparation your mind may be elsewhere anticipating the excitement of the first flight. Because of this, you may be more likely to overlook certain checks and procedures that should be performed before the model is flown. To help avoid this, a check list is provided to make sure these important areas are not overlooked. Many are covered in the instruction manual, so where appropriate, refer to the manual for complete instructions. Be sure to check the items off as they are completed (that's why it's called a *check list!*).

1. Check the C.G. according to the measurements provided in the manual.
2. Be certain the battery and receiver are securely mounted in the fuse. Simply stuffing them into place with foam rubber is not sufficient.
3. Extend your receiver antenna and make sure it has a strain relief inside the fuselage to keep tension off the solder joint inside the receiver.
4. Balance your model *laterally* as explained in the instructions.
5. Use threadlocking compound to secure critical fasteners such as the motor screws, wheel collar SHC screws and screw-lock pushrod connectors, etc.
6. Add a drop of oil to the axles so the wheels will turn freely.
7. Make sure all hinges are **securely** glued in place.
8. Reinforce holes for wood screws with thin CA where appropriate (servo mounting screws, control horn screws, etc.).
9. Confirm that all controls operate in the correct direction and the throws are set up according to the manual.
10. Make sure there are silicone retainers on all the clevises and that all servo arms are secured to the servos with the screws included with your radio.
11. Secure connections between servo wires and Y-connectors or servo extensions with vinyl tape, heat shrink tubing or special clips suitable for that purpose.
12. Make sure any servo extension cords you may have used do not interfere with other systems (servo arms, pushrods, etc.).
13. Balance your propeller (and spare propellers).
14. Tighten the propeller nut and spinner.
15. Place your name, address, AMA number and telephone number on or inside your model.
16. If you wish to photograph your model, do so before your first flight.
17. Range check your radio when you get to the flying field.

FLYING

The Factor 3D EP ARF is a great-flying model that flies smoothly and predictably. Factor 3D EP ARF does not, however, possess the self-recovery characteristics of a primary R/C trainer and should be flown only by experienced R/C pilots. **As you can see the airplane is a very lightly built structure. This is big reason for the terrific performance of the model. Because of the structure it is important that landings are performed at slow speeds. We recommend the Factor 3D ARF be flown from hard surfaces or very short grass fields to avoid damage.**

CAUTION (THIS APPLIES TO ALL R/C AIRPLANES): If, while flying, you notice an alarming or unusual sound such as a low-pitched “buzz,” this may indicate control surface *flutter*. Flutter occurs when a control surface (such as an aileron or elevator) or a flying surface (such as a wing or stab) rapidly vibrates up and down (thus causing the noise). In extreme cases, if not detected immediately, flutter can actually cause the control surface to detach or the flying surface to fail, thus causing loss of control followed by an impending crash. The best thing to do when flutter is detected is to slow the model **immediately** by reducing power, then land as soon as safely possible. Identify which surface fluttered (so the problem may be resolved) by checking all the servo grommets for deterioration or signs of vibration. Make certain all pushrod linkages are secure and free of play. If it fluttered once, under similar circumstances it will probably flutter again unless the problem is fixed. Some things which can cause flutter are; Excessive hinge gap; Not mounting control horns solidly; Poor fit of clevis pin in horn; Side-play of wire pushrods caused by large bends; Excessive free play in servo gears; Insecure servo mounting; and one of the most prevalent causes of flutter; Flying an over-powered model at excessive speeds.

Takeoff

Only attempt takeoffs and landings from a hard surface or very short grass. Before you get ready to takeoff, see how the model handles on the ground by doing a few practice runs at **low speeds** on the runway. Hold “up” elevator to keep the tail wheel on the ground. If necessary, adjust the tail wheel so the model will roll straight down the runway. If you need to calm your nerves before the maiden flight bring the model back into the pits, peak the battery and check all fasteners and control linkages for peace of mind.

Remember to takeoff into the wind. When you're ready, point the model straight down the runway, hold a bit of up elevator to keep the tail on the ground to maintain tail wheel steering, and then gradually advance the throttle. As the model gains speed decrease up elevator allowing the tail to come off the ground. One of the most important things to remember with a tail dragger is to always be ready to apply **right** rudder to counteract engine torque. Gain as much speed as your runway and flying site will practically allow before gently applying up elevator, lifting the model into the air. At this moment it is likely

that you will need to apply more right rudder to counteract motor torque. Be smooth on the elevator stick, allowing the model to establish a **gentle** climb to a safe altitude before turning into the traffic pattern.

Flight

For reassurance and to keep an eye on other traffic, it is a good idea to have an assistant on the flight line with you. The Factor 3D EP ARF with the recommended power system will only require full throttle in short burst. Most aerobatic flight can be performed at around 1/3 to 1/2 throttle. If you observe the flight of some of the best aerobatic pilots, they very seldom use full throttle.

Take it easy with the Factor 3D EP ARF for the first flight, gradually getting acquainted with it as you gain confidence. Adjust the trims to maintain straight and level flight. After flying around for a while, and while still at a safe altitude with plenty of battery, practice slow flight and execute practice landing approaches by reducing the throttle to see how the model handles at slower speeds. Add power to see how she climbs as well. Continue to fly around, executing various maneuvers and making mental notes (or having your assistant write them down) of what trim or C.G. changes may be required to fine tune the model so it flies the way you like. Mind your battery power level, but use this first flight to become familiar with your model before landing. With most electric planes it is best to have a timer set on your transmitter or a separate timer with an alarm to alert you when the battery may be getting low. This will require a few flights before determining the maximum flight time you can achieve with the batteries. This will prevent the downwind auto motor cutoff over the end of the flying field. With the plane properly trimmed you will want to get started with some aerobatics. This plane is capable of just about every aerobatic maneuver you can do. Become familiar with the high and low rate settings before using the 3D rates. If you have not flown an airplane with 3D rates you should work your way into these higher 3D rates cautiously. The extreme throws can stall the airplane if you are not careful. Over controlling could also result in unwanted snaps. If you have not flown 3D you might want to consider getting help from an experienced 3D pilot. When executing down line maneuvers it is important to use good throttle management. Full power down lines could result in over stressing of the aircraft.

Landing

To initiate a landing approach, lower the throttle while on the downwind leg. Allow the nose of the model to pitch downward to gradually bleed off altitude. Continue to lose altitude, but maintain airspeed by keeping the nose down as you turn onto the crosswind leg. Make your final turn toward the runway (into the wind) keeping the nose down to maintain airspeed and control. Level the attitude when the model reaches the runway threshold, modulating the throttle as necessary to maintain your glide path and airspeed. If you are going to overshoot, smoothly advance the throttle (always ready on the right rudder to counteract torque) and climb out to make another attempt. When you're ready to make your landing flare

and the model is a foot or so off the deck, smoothly increase up elevator until it gently touches down. Once the model is on the runway and has lost flying speed, hold up elevator to place the tail on the ground, regaining tail wheel control. Try to land slowly and gently.

One final note about flying your model. Have a goal or flight plan in mind for **every** flight. This can be learning a new maneuver(s), improving a maneuver(s) you already know, or learning how the model behaves in certain conditions (such as on high or low rates). This is not necessarily to improve your skills (*though it is never a bad idea!*), but more importantly so you do not surprise yourself by impulsively attempting a maneuver and suddenly finding that you've run

out of time, altitude or airspeed. Every maneuver should be deliberate, not impulsive. For example, if you're going to do a loop, check your altitude, mind the wind direction (anticipating rudder corrections that will be required to maintain heading), remember to throttle back at the top, and make certain you are on the desired rates (high/low rates). A flight plan greatly reduces the chances of crashing your model just because of poor planning and impulsive moves. **Remember to think.**

Have a ball! But always stay in control and fly in a safe manner.

GOOD LUCK AND GREAT FLYING!

This model belongs to:	_____
	Name

	Address

	City, State, Zip

Phone Number	

AMA Number	

