

Piper J-3 Cub Balsawood Airplane



Specification:

Wingspan: 1800mm
 Fuselage Length: 1150mm
 Flying weight: 2.2-2.6kg

Suggested Equipment:

Motor: 4250(3520) 600KV
 ESC: 60A
 Servo: 17g x4 (EP version)
 17g x5 (GP version)
 Propeller: 12-14 inch
 Battery: 4-6S 3000-6000mAh
 Radio :more than 4CH
 GP: 50-60 class methanol
 or same class engine

Accessories

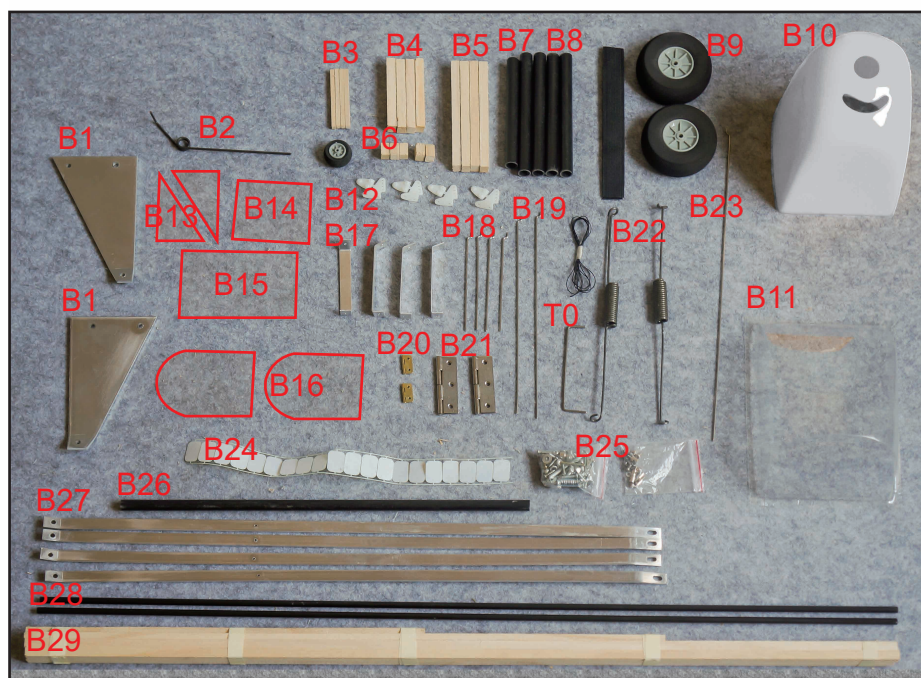

- B1.B22. Front Landing Gear
- B2. Back Landing Gear
- B3. Balsa wood sheet
- B4.B6. Wood Brace for screw-assembly on the wing
- B5. Wood Brace for screw-assembly on the front landing gear
- B7. Carbon Tube 12mm*110mm
- B8. Carbon Tube 12mm*124mm
- B9. Wheel
- B10. Cowling
- B11. Cabin Canopy
- B12. Servo horn
- B13.B14.B15.B16. PVC window sheet
- B17.B27 Wing Bracket
- B18. B19.B23 Servo Pull Rod
- B20. Cabin Door Hinges
- B21. Landing Gear Hinges
- B24. Paper Hinges
- B25. Set Screws; Linkage stoppers
- B26. Carbon Tube 10mm*358mm
- B28. Carbon Tube 6mm*746mm
- B29. Paulownia Sheet

How to Assemble the Fuselage

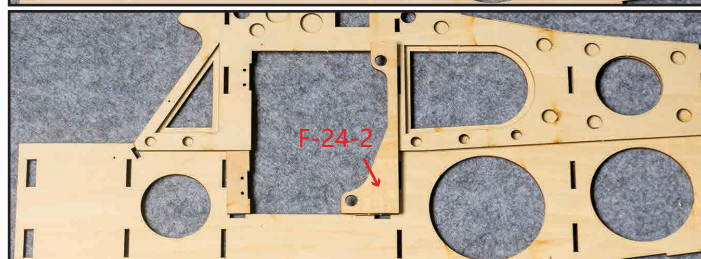
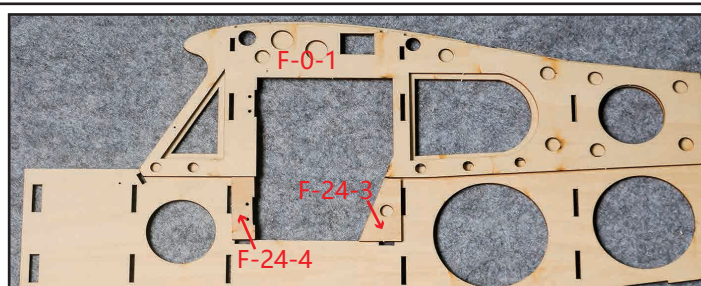
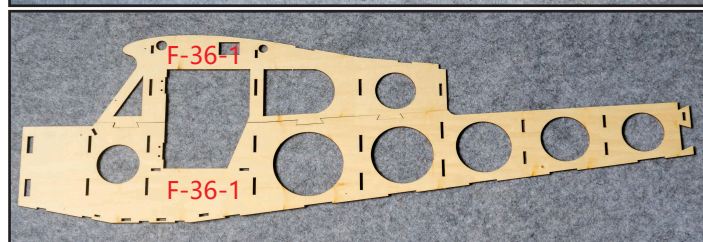
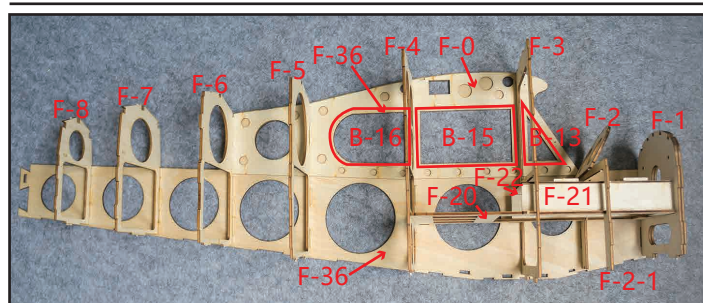

Piper J-3 Cub Balsa Wood Airplane

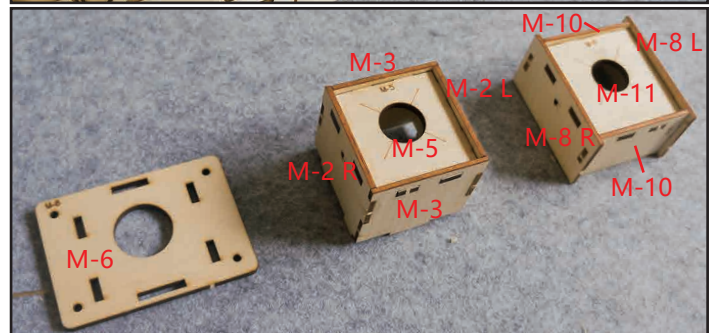
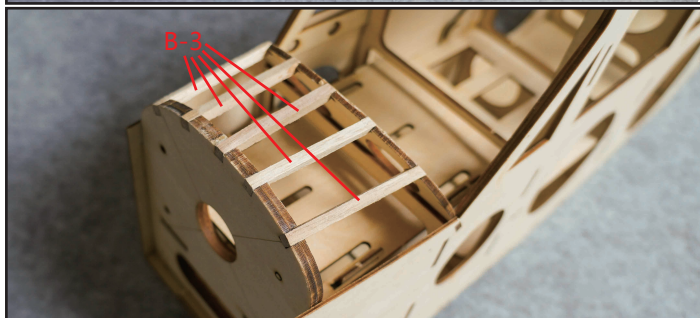
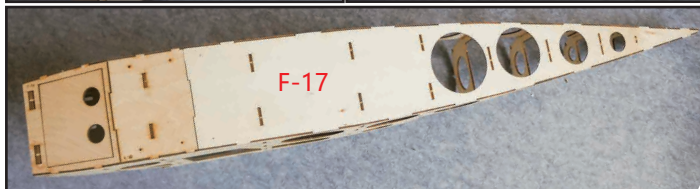
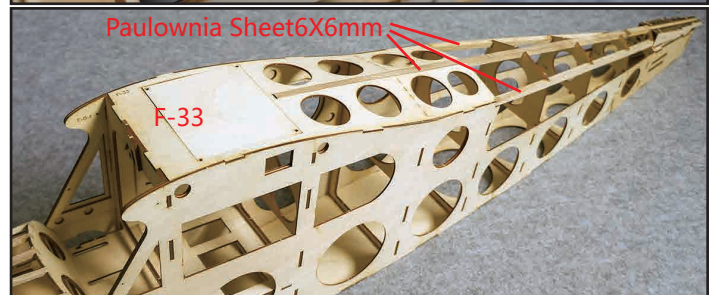
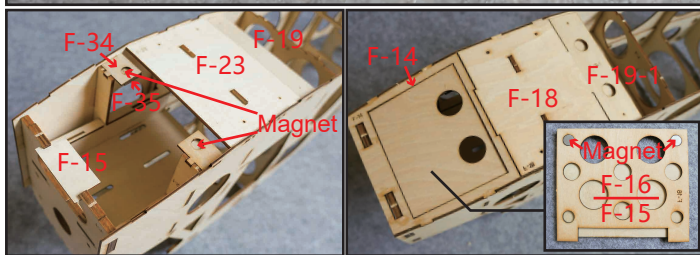
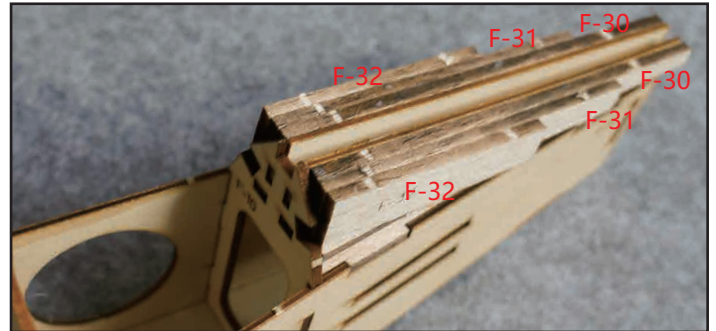
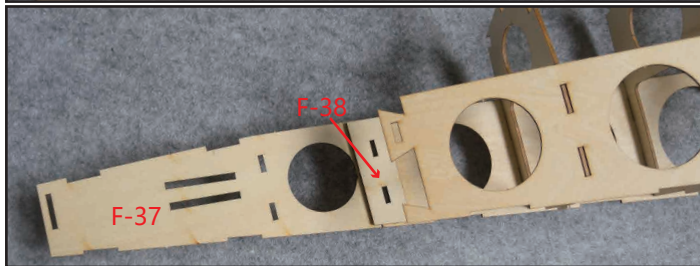
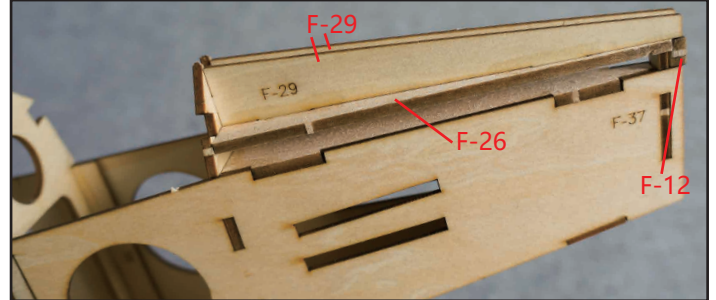
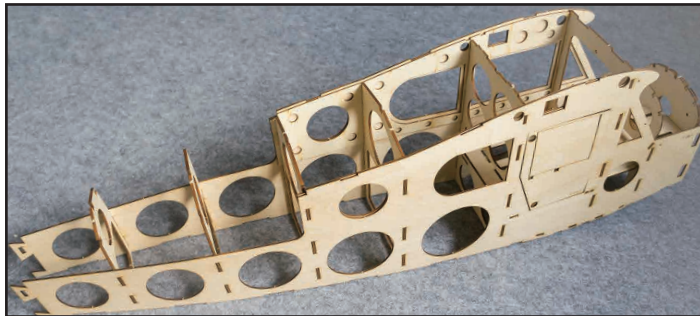
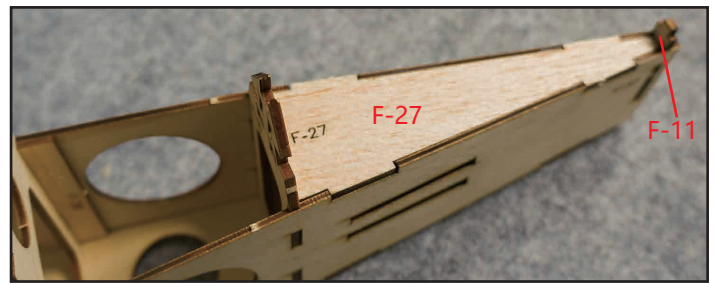
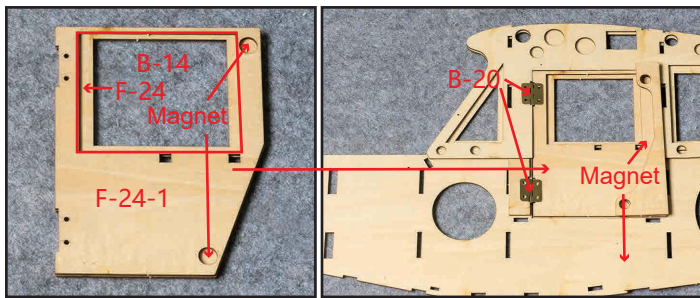

Piper J-3 Cub Balsawood Airplane

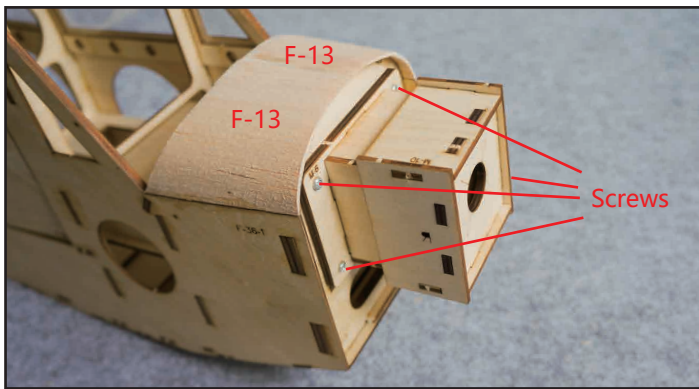

How to assemble the Landing Gear

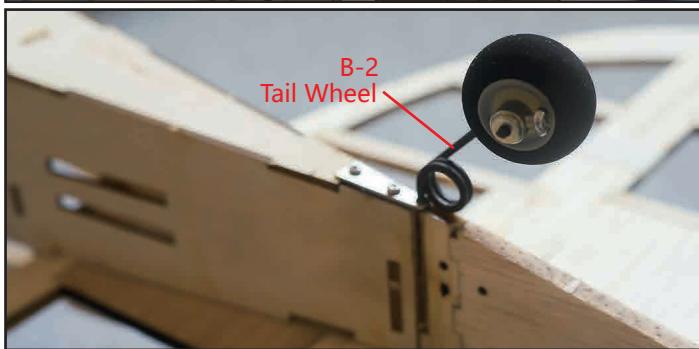
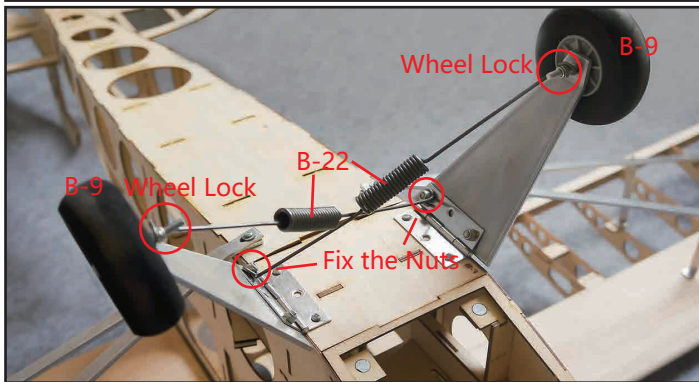
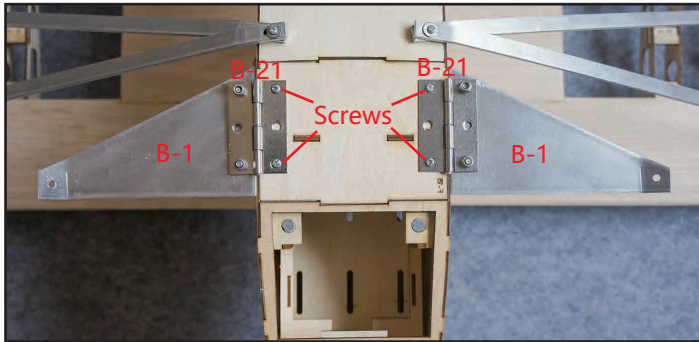

How to assemble the wing and parts

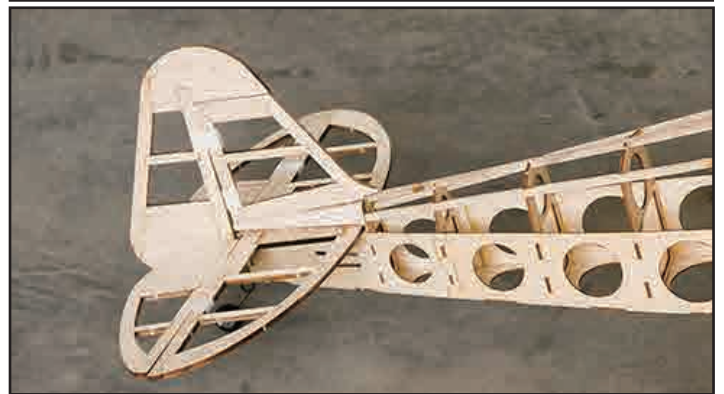
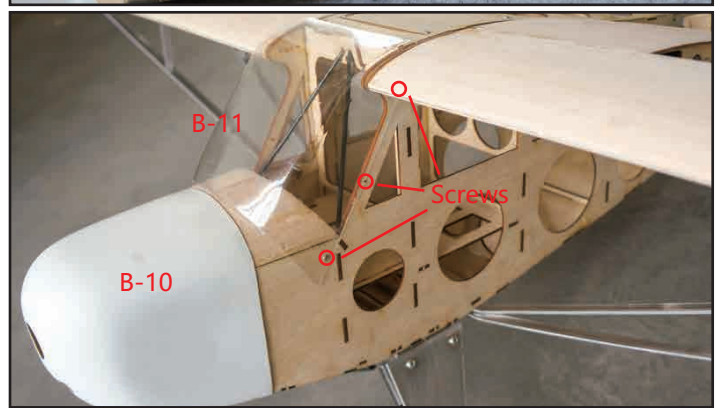
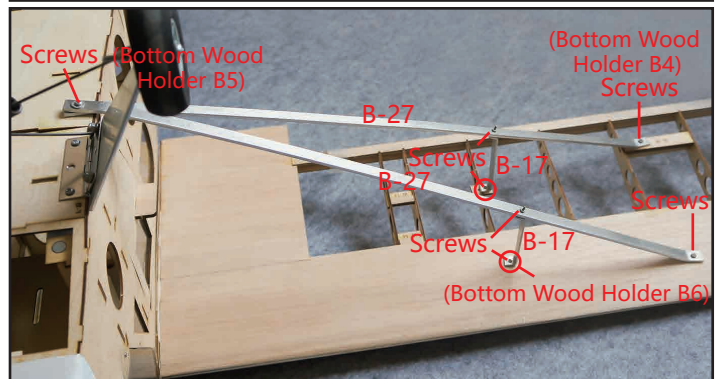
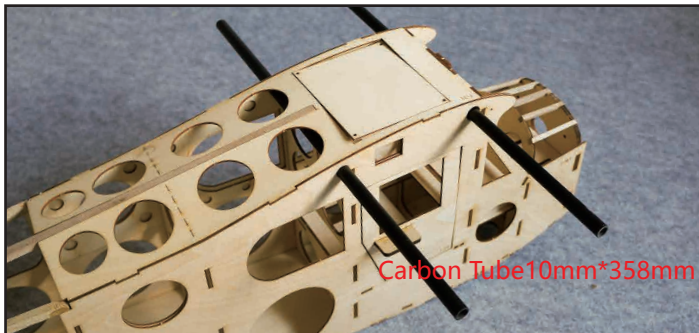

Piper J-3 Cub Balsawood Airplane

How to assemble the Horizontal Tail Wing

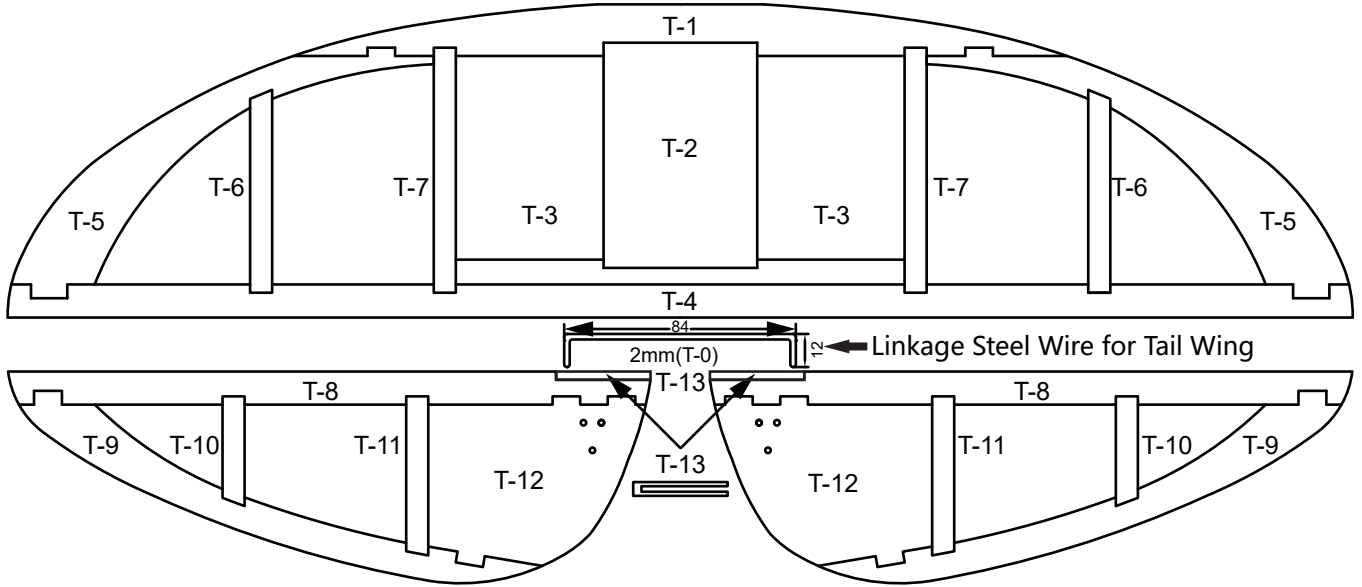

How to assemble the Vertical Tail Wing

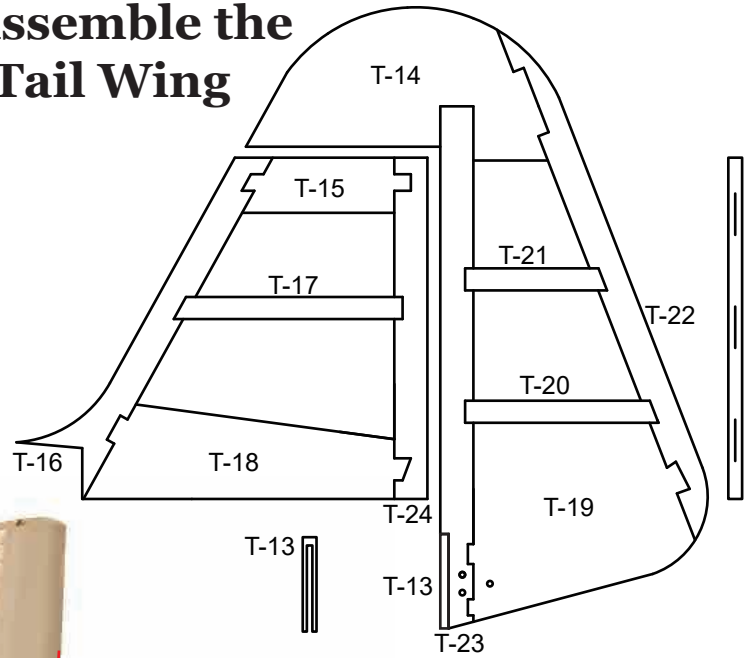

Display the C.G

