

INTRODUCTION



NEW PRODUCT

SAITO 4-stroke Radial Gasoline engine for model aircraft.

Have you kept waiting so long ?

We would like to introduce our new product, FG-60R3 !

Thrill sound of 3cylinder would amazingly hit to your heart. Popular middle class of 50CC will be an ideal size ,and widen your choice for RC life.

It is sure your RC life and even your human life will be drastically changed by this engine !

We persuade the FG-60R3 for everyone with confidence.



Specifications

- Bore : 32×3 mm
- Stroke : 25×3 mm
- Disp : 60.32
- Weight : Main body : approx.1800g
Ignition : approx.195g , Muffler set : approx.90g
- Propeller : 21"x10"~23"x8" (inch)
- Practical Range: 1,500rpm~7,000rpm
- Static thrust : approx. 7kg (w/ MEJ22x10, 6.700rpm)
- Fuel efficiency :approx.30 (cc/min)

FG-60R3

FG-60R3 2D Dimension

ボア (Bore)	32 × 3 (mm)
ストローク (Stroke)	25 × 3 (mm)
行程容積 (Disp)	60.32 (cc)
ストローク・ボア比 (S/B)	0.78
重量 (Weight)	エンジン本体 1,800 (g)
	マフラー式 90 (g)
	イグニッション 195 (g)
実用回転数 (Practical Range)	1,500~7,000 (rpm)
プロペラ (Prop)	21 × 10~23 × 8 (inch)
静止推力 (Static thrust)	MEJZLIK 22 × 10-約7kg (6,700rpm)
燃料消費量 (Fuel Efficiency)	約30 (cc/min)

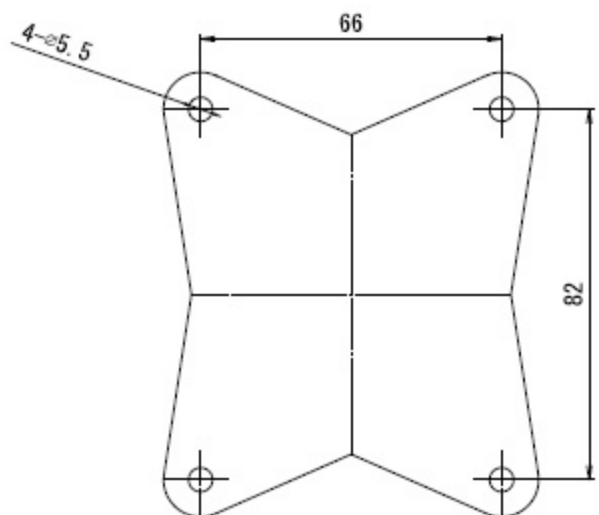

マウント取付寸法

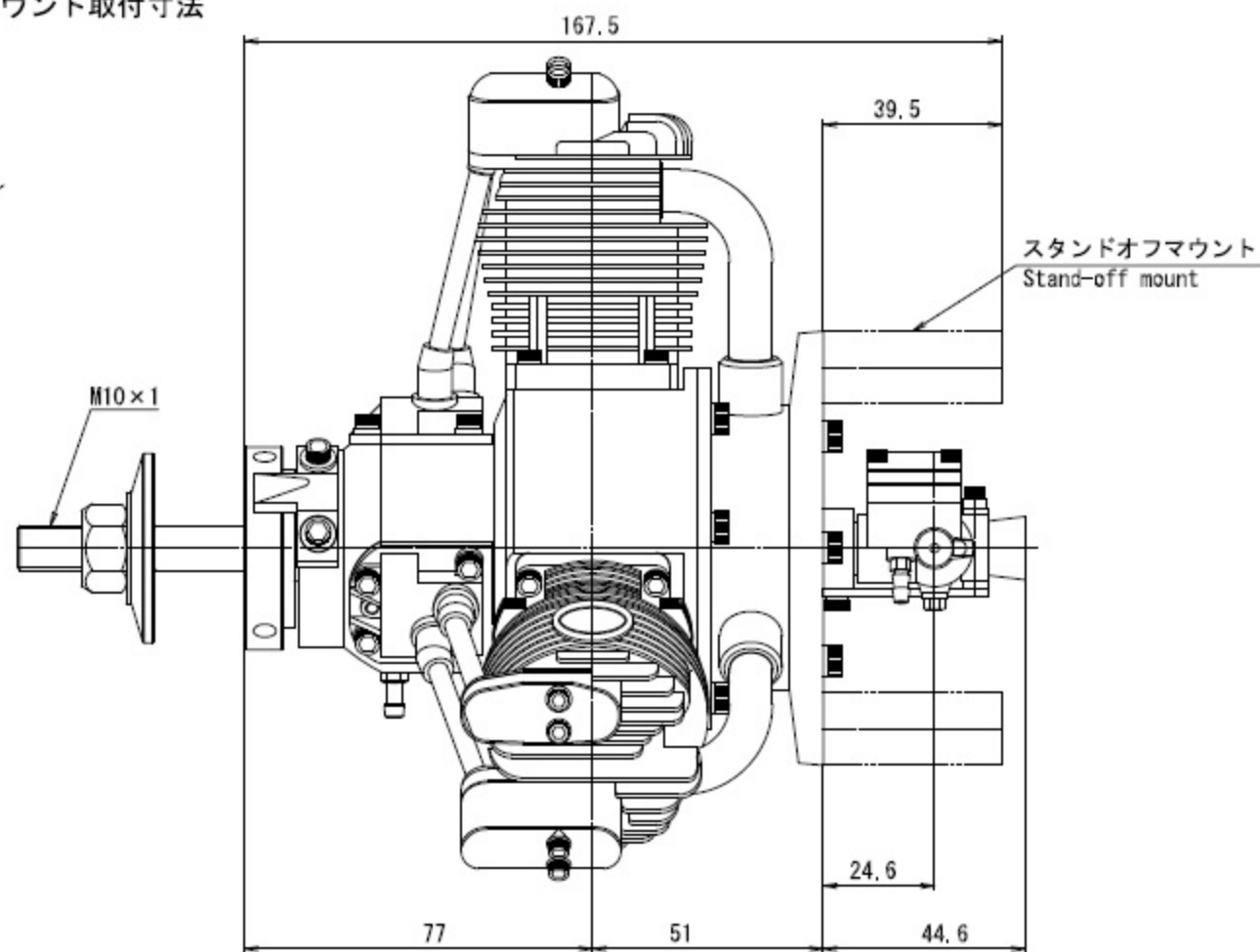
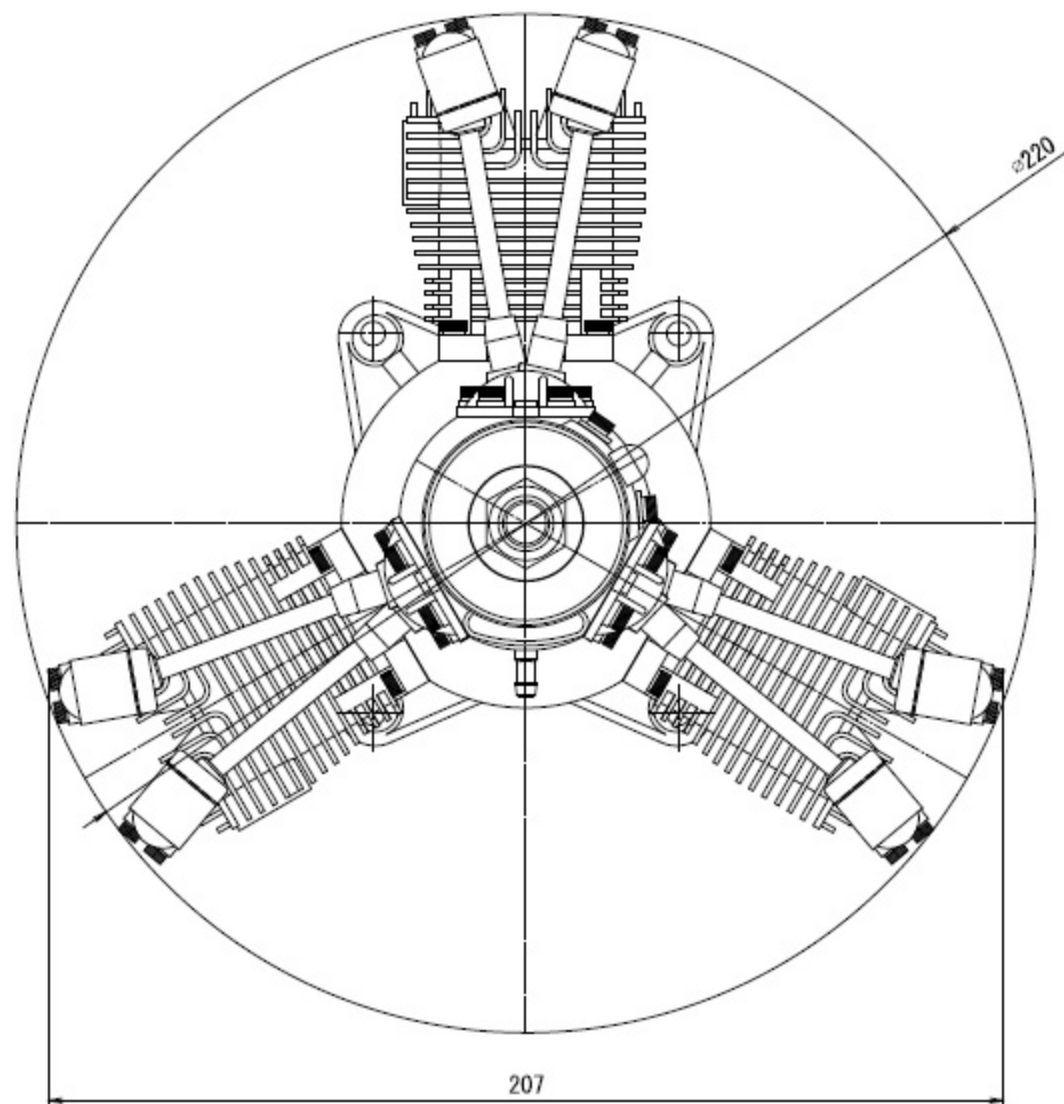

スタンドオフマウント
Stand-off mount